

Double Suction Vertical In-Line Centrifugal Pumps

CSV SERIES



CSV Serisi
ATEX Version



OPERATING MANUAL



Mas Grup





EC DECLARATION OF CONFORMITY

AT UYGUNLUK BEYANI

Manufacturer / İmalatçı : MAS DAF MAKİNA SANAYİ A.Ş.

Address / Adres : Aydınlı Mah. Birlik OSB. 1.No' lu Cadde No:17 Tuzla - İSTANBUL / TÜRKİYE

Name and address of the person authorized to compile the technical file Vahdettin YIRTMAÇ
Aydınlı Mah. Birlik OSB. 1.No' lu Cadde No:17
Teknik Dosyayı Derleyen Yetkili Kişi ve Adresi Tuzla - İSTANBUL / TÜRKİYE

The undersigned Company certifies under its sole responsibility that the item of equipment specified below satisfies the requirements of the mainly Machinery Directive 2006/42/EC which is apply to it.

The item of equipment identified below has been subject to internal manufacturing checks with monitoring of the final assessment by MAS DAF MAKİNA SANAYİ A.Ş.

Aşağıda tanımlanmış olan ürünler için Makine Emniyeti yönetmeliği 2006 / 42 / AT' nin uygulanabilen gerekliliklerinin yerine getirildiğini ve sorumluluğun alınmış olduğunu beyan ederiz.

Aşağıda tanımlanan ürünler iç üretim kontrollerine bağlı olarak MAS DAF MAKİNA SANAYİ A.Ş. tarafından kontrol edilmiştir.

Equipment / Ürün : Çift Emişli Düşey In-Line Santrifuj Pompalar
Double Suction Vertical In-Line Centrifugal Pumps
Seri / Model-Tip : CSV Serisi – CSV Series

For pumps supplied with drivers/ Elektrikli Pompa Üniteleri Related Directives / Yönetmelikler
2006/42/EC Machinery Directive / 2006/42/AT Makine Emniyeti Yönetmeliği
2014/35/EU Low Voltage Directive / 2014/35/AB Alçak Gerilim Yönetmeliği
2014/30/EU Electromagnetic Compatibility Directive / 2014/30/AB Elektromanyetik Uyumluluk Yönetmeliği
EUP 2009/ 125 /EC Electric Used Products Directive/ Elektrik Kullanan Ekipmanlar Direktifi (EUP)
94/9/EC Equipment For Explosive Atmospheres / Patlayıcı Ortamlardaki Ekipman Yönetmeliği

Regulations applied acc. to harmonize standards / Uygulanan Uyumlaştırılmış Standartlar
TS EN ISO 12100:2010, TS EN 809+A1, TS EN 60204-1:2011.

We hereby declare that this equipment is intended to be incorporated into, or assembled with other machinery to constitute relevant machinery to comply with essential health and safety requirements of Directive The machinery covered by this declaration must not be put into service until the relevant machinery into which it is to be incorporated has been declared in conformity with provisions of the directive.

Ekipman, uygun bir makina oluşturmak amacıyla diğer ekipmanlar ile birleştirilirken ya da monte edilirken gerekli sağlık ve güvenlik yönetmeliklerine uyulması gerekmektedir.

Bu bildiri kapsamında yönetmelikte belirtilen bütün hükümler yerine getirilmeden makinanın devreye alınmaması gerekmektedir.

Place and date of issue / Yer ve Tarih : İstanbul, 02.06.2014
Name and position of authorized person : Vahdettin YIRTMAÇ
Yetkili Kişinin Adı ve Görevi : General Manager / Genel Müdür
Signature of authorized person :
Yetkili Kişinin İmzası

TABLE OF CONTENTS	Page No
Introduction	1
1.Important Safety Precautions	1
2.General	1
3.Safe Operating Conditions	2
4.Technical Information	3
5.Transport and Storage	4
6.Assembly/Installation	4
6.1.Location of Installation	4
6.2. Type of Connection	4
6.3. Foundation	4
6.4. Coupling Alignment	5
6.5. Piping	6
6.6. Motor Connection	7
7.Commissioning, Start up and Operating	7
7.1.Preparations Before Start up	7
7.2. Checking The Direction of Rotation	7
7.3. Start up Procedure	7
7.4. Shut Down Procedure	8
8.Maintenance	8
8.1. The Checks During the Operation	8
8.2. Maintenance Instructions in ATEX Version Pumps	9
8.3. Service	9
8.4. Spare Parts	9
9.Noise Level and Vibration	9
10. Disassembly, Repair and Reassembly	10
11. Possible Failures, Causes, Solutions	11
12. Pump Dimensions Table	12
13. Sample Plumbing	13
14. CSV Sectional Drawing and Part List	14
15. Figure List	15
16. Table List	15

1. IMPORTANT SAFETY PRECAUTIONS

In order to minimize the accidents during the mounting and putting into service of the pump, the following rules have to be applied:

1. Do not work without taking safety measures relevant to equipment. Cable, mask and safety band must be used when necessary.
2. Be sure there is adequate amount of oxygen and there is no toxic gaseous around
3. Before using welding or any electrical equipment make sure that there is no risk of explosion.
4. Check the cleanliness of the area to take care of your help. (Dust, smoke, etc.)
5. Do keep in mind that there is a risk of having accidents related to electricity
6. Do not lift the pump before you check the transport equipment.
7. Be sure you have a by-pass line
8. Use helmet, eye glasses and protective shoes for your safety
9. Place a protective barrier around the pump within the necessary safety area
10. Dust, liquids and gaseous that may cause overheating, short circuit, corrosion and fire must be kept away from the pump unit.
11. By checking the noise level of the pump unit, necessary measures to avoid noisy operation of the pump that can have harmful effects on the personnel and environment.
12. Be careful about the direction of transport and storage.
13. Cover appropriately the moving parts to avoid possible injury of the personnel. Mount the coupling guard and belting before starting-up the pump
14. All the electrical and electronic applications must be performed by authorized person conforming EN60204-1 and /or domestic instructions.
15. Protect the electrical equipment and motor against overloading
16. If flammable and explosive liquids are pumped, ground connection of electricity should be carried out properly
17. Do not expose the pump unit to sudden temperature variations
18. All personnel who work with the waste water system need to be vaccinated in case of contagious diseases.
19. If the pump contains hazardous liquids, one must use protective helmet against the risk of splatter. One also must accumulate the liquid in a proper container against any risk of leakage.

All Other Health and Safety Rules, Laws and Regulations Must Be Applied

2. GENERAL

2.1. Definition of pump and usage areas

CSV series are double suction vertical in-line centrifugal pumps. They are used in;

- Pumping ballast in ships
- Pumping cooling water
- As general service pump
- Water transferring
- Loading-discharging storage and tank
- In industrial and social facilities

CAUTION

Please contact MAS DAF MAKINA SANAYI A.Ş. for liquids that have different chemical and physical specifications.

Technical specifications of CSV type pumps

Suction Flange:	DN 300-DN 400
Discharge Flange:	DN 250-DN 350
Operating Pressure:	10 bar
Capacity:	400-2200 m ³ /h
Hm:	10-60m.
Speed:	730-1800 rpm

INTRODUCTION



- This manual contains instructions for the installation, operation and maintenance of the CSV type double suction vertical in-line centrifugal pumps of **MAS DAF MAKINA SANAYI A.Ş.**
- Please read carefully this manual and apply all the instructions to operate pumps without problems. Pumps shall be used for their intended duties. In this manual, there are information on operating conditions, installation, starting-up, settings and main controls of pumps.
- These operating and maintenance instructions contain **MAS DAF MAKINA SANAYI A.Ş.**'s suggestions. The special operating and maintenance information of the plumbing that a pump is fitted to is not considered in these instructions. This information must be given by the plumbing constructors only.
- **Please refer to instructions of plumbing constructors.**
- Please pay attention to the warnings in this manual and ensure that it is read before the installation-start up process. **MAS DAF MAKINA SANAYI A.Ş.** is not responsible for the accidents resulting from negligence.
- If you cannot find an answer to your questions in this manual, it is suggested that you contact **MAS DAF MAKINA SANAYI A.Ş.** Please inform us about the rated value and especially the serial number of the pump when you get in contact for help.
- The safety instructions in this manual cover the current national accident protection regulations. Beside all of these, an operation, work and safety measure imposed by the costumer has to be applied.

The Signs Used in This Operation Manual



Read the instructions carefully in this operating manual and keep it for your future reference.



Warning sign against the electrical risks.



Sign for the operator's safety.



Sign for protecting against explosion.



Figure 1: Pump Label



Figure 2: ATEX Version Pump Label

2.6. ATEX Description

The undersigned Company certifies under its sole responsibility that the item of equipment specified below satisfies the requirements of the ATEX Directive 94/9/EC which is apply to it. Please read cautiously all instructions emphasized with ATEX sign in this manual.

ATEX Codification

ATEX -95



II 2G /D c Tx (85 °C – 200 °C)

Equipment Groups (Annex I of Directive 94/9/EC)							
Group I (mines, mine gas and dust)		Group II (other explosive atmospheres gas/dust)					
Category M 1	Category M 2	Category 1		Category 2		Category 3	
		G (gas) (Zone 0)	D (dust) (Zone 20)	G (gas) (Zone 1)	D (dust) (Zone 21)	G (gas) (Zone 2)	D (dust) (Zone 22)
For equipment providing a very high level of protection when endangered by an explosive atmosphere	For equipment providing a high level of protection when likely to be endangered by an explosive atmosphere	For equipment providing a very high level of protection when used in areas where an explosive atmosphere is very likely to occur		For equipment providing a high level of protection when used in areas where an explosive atmosphere is likely to occur			For equipment providing a normal level of protection when used in areas where an explosive atmosphere is less likely to occur

2.2. Performance information

Actual performance of the pump can be obtained from the order page and/or from the test report. This information is given on the pump label. The performance curves given in the catalog are valid for water whose density and viscosity are $\rho=1 \text{ kg/dm}^3$ and $\nu=1 \text{ cst.}$ respectively. For those liquids whose densities and viscosities are different from those of water, please consult with **MAS DAF MAKINA SANAYI A.Ş.** since the performance curves vary with density and viscosity



Do not operate the pump with a motor that has a different power except for the given catalog and label values.

The pump is not to be operated at off-design point given in the order and supplied from the firm. It is necessary to ensure that the instructions are obeyed for the safe running of the pump.

2.3. Warranty conditions

The entire products in our selling program are warranted by **MAS DAF MAKINA SANAYI A.Ş.**

The warranty conditions will only be valid when all the instructions about installation and start-up operations of the pump unit are taken into account.

2.4. Test

All Pumps are dispatched for sale when all the performance and pressure tests are completed. Proper assurance of material and fault-free operation of pumps whose performance tests are made is under the warranty of **MAS DAF MAKINA SANAYI A.Ş.**

2.5. Pressure limit



Pressure at the discharge flange must not exceed 10 Bar. A special order is necessary for applications with higher pressures.

TEMPERATURE CLASS		
Temperature class required by the area classification	Ignition temperature of gas or vapor	Allowable temperature classes of equipment
T1	> 450 °C	T1 - T6
T2	> 300 °C	T2 - T6
T3	> 200 °C	T3 - T6
T4	> 135 °C	T4 - T6
T5	> 100 °C	T5 - T6
T6	> 85 °C	T6

Code	Description
II	The Usage in other non-mining explosive atmospheres
2	2. Category: High level of protection
G	For potentially explosive environments due to gases or vapors
T	Temperature class
X	ATEX Marking of the motor manufacturer

3. SAFE OPERATING CONDITIONS

This manual contains main safety instructions for the installation, operation and maintenance. It must be read by the personnel who are responsible for installation and operation. This manual should always be kept near the installation location. It is important to comply with safety precautions stated in page 1 along with the general safety instructions as well as preventive measures repeated in other sections of this manual.

3.1. Training of personnel

Installation, operation and maintenance personnel must have necessary knowledge in order to accomplish the given job. The responsibility, adequacies and controlling duties of such personnel must be determined by the customer. It has to be certain that these personnel comprehend totally the content of the operating manual. If the personnel do not have enough knowledge, required training must be given by the customer. If training support is needed by the customer, it will be provided by the manufacturer/seller.

CAUTION

Untrained personnel and unwillingness to comply with safety instructions may be risky for both machine and environment. **MAS DAF MAKINA SANAYI A.Ş.** is not responsible for this kind of damages.

3.2. Hazardous conditions that may occur when one does not comply with the safety instructions

Incompliance with safety regulations may put the personnel, the environment and the machine in danger and thus may cause damages. Incompliance with safety regulations may give rise to situations listed below.

Important operational functions of the factory may stop.

Maintenance may get difficult.

One may get injured by electrical, mechanical or chemical hazards.

3.3. Safety measures for operator

Dangerous, hot or cold components in the pump area must be covered so that one cannot touch them.

Moving components of the pump (such as coupling) must be covered so that one cannot touch them. Those covers must not be dismantled while the pump is running. Dangers that results from electrical connections must be removed. To get more information about this subject, you can refer to domestic electrical instructions.

3.4. Safety measures for maintenance and installation

The costumer must assure that all maintenance, check and installment tasks are performed by qualified personnel. Repair work must only be performed while the machine is not running.

The pump and its auxiliary system must be cleaned thoroughly if it contains hazardous liquids. At the end of the repair work, all safety and protective equipment must be re-installed.

3.5. Informations about Protection against Explosion

The instructions specified intended for protection against explosion should be noted definitely during commissioning of the pump unit in environments with explosion risk.

Only pumps or pump units having related definitions and adequate suitability must be used in environments with explosion risk. The explosion protection should be noted that it is possible only with the use according to the instructions.



Limit values specified at the ATEX version pump label must not be exceeded definitely.

NOTE: If the categories are different depending on pump and motor temperatures it applies the lowest category.

Ensure that the coupling used for accouplement of motor and pump has ATEX sign.



Avoid all improper commissioning and installation in environments with explosion risk. Otherwise, the pump unit and/or the staff can be exposed to damage/injury. Consider the local explosion protection regulations and the informations at ATEX version pump label.



Check whether ATEX specification on the motor and the pump coincide with specified categories. Consider that if the categories of the pump and the motor are different it applies the lowest category.

3.6. Spare parts replacement

Replacement of spare parts and all modifications must be done after contacting with the manufacturer. Spare parts and accessories certified by the manufacturer are important for the safe operation of the system.

Notice: **MAS DAF MAKINA SANAYI A.Ş.** is not responsible from the usage of improper spare parts.

4. TECHNICAL INFORMATION

4.1. Design

CSV series adouble suction vertical in-line centrifugal pumps are furnished with standard pumps and mechanical sealings.

4.1.1. Locations of flange – Flanges

Discharge Flanges: DIN 2533 - PN 10

Suction Flanges: DIN 2533 - PN 10

4.1.2. Connection of pump and motor

Motor is close coupled to the pump with a rigid coupling using and an adapter and flange. In this way, the shafts of the motor and pump constitute a complete unit.

4.1.3. Impeller

The impellers of CSV type pumps are (full) radial, double-sloped (Francis type) or mixed flow types. The impellers are balanced dynamically in an electronic balance machine. High suction values are provided with two-sided suction design bu reducing NPSH values at impeller and pump efficiency is improved.

4.1.4. Shaft

The shaft, impeller and other parts of the pump is designed to be dismountable without moving (dislodge) the suction and discharge pipes and volute of the pump. In this way, the installation and maintenance operations can be performed very easily.

4.1.5. Bearing and lubrication

Rolling bearing is used in CSV type pumps. Bearing is provided with two grease lubricated, 6300 C3-type deep groove ball bearings according to DIN 625.

4.1.6. Seals

In standard production, various mechanical seal types (e.g. bellow type, spring actuated type) are used for sealing.

4.2. Construction of pump group

4.2.1. Drive

TEFC (Totally Enclosed Fan Cooled) 3 phase, squirrel caged, in accordance to DIN 42673, IM 2001B35 type (with flange) electrical motor which complies with DIN IEC and VDE is used to drive the pump in proper speed and power.

Specifications of electrical motor;

Isolation class: F

Protection class: IP 54-IP 55

Frequency: 50/60 Hz

Running type: S1

Start up type: 3x380V (Δ)+(Y/ Δ)

4.2.2. Coupling and coupling guard

At CSV type pumps, a flexible coupling is used. A coupling guard is given in accordance with EN 953.

 **Pump can only be run with a coupling guard in accordance with EN 953 according to safety instructions. If there is no coupling cover, it is provided by the operator.**

5. TRANSPORT AND STORAGE

Suction, discharge and all auxiliary fittings must be closed during transport and storage. Dead-end covers must be removed while the pump unit is being installed.

5.1. Transport

Pump and pump group must be carried safely to the installation location by lifting equipments.

CAUTION

Current general lifting safety instructions must be applied. Please use a suspension system shown in figure while you are carrying and lifting the pump unit. The suspension rings may be broken because of the excessive load and may result in a damage of the pump. Prefer fabric cable for suspension.

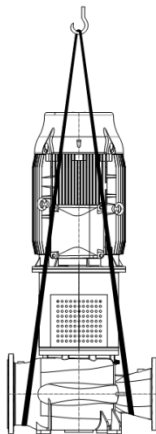

Figure 3: Transport of Pump Group



Incorrect lifting may damage the pump unit and cause injuries.

Damages caused in transport

Check the pump when it is delivered to you. Please let us know of there is any damage.

5.2. Storage



Please keep the unit clean and dry area during storage.

If the pump is out of use for a long time, please consider the instructions below.

1. If there is water inside the pump, drain it.
2. Clean the pump casing and impeller by jetting clean water for a short time.

3. Empty water inside the pump casing, suction line and discharge line.
4. Add small amount of antifreeze inside the pump casing if it is not possible to empty it completely. Rotate the pump shaft by hand to mix the antifreeze.
5. Close the suction and discharge exits with gasket
6. Spray an anti-corrosive into the pump casing.
7. Rotate the pump shaft by hand once in every month, in order to protect it from freezing and to lubricate the bearings.

6. ASSEMBLY / INSTALLATION

CSV series pumps are connected to the foundation of the volute foot.

6.1. Location of installation

Pump shall be installed in a location where the control and the maintenance of the pump are easily made. The pump room shall be suitable for operation of lifting systems such as freight elevator, forklift, etc.

The pump group should be installed in the lowest possible location of the pumping system in order to achieve the highest suction pressure.

6.1.1. Location of Installation- Local Ambient Temperature

When the local ambient room temperature exceeds +40°C in a pumping system, suitable ventilation should be provided in order to remove the heat dissipated to the environment and supply fresh air.

6.2. Type of connection

Type of connection depends on the design type and the size of the pump and the motor, as well as the local installation conditions.

6.3. Foundation

6.3.1. General

Base plate of the pump must be grouted. The foundation shall be of concrete or steel framework.

NOTICE: The foundation shall distribute the weight of the pumping group evenly.

6.3.2. Foundation properties

The foundation shall be horizontal, flat and clean and shall support all the weight.

NOTICE: Reinforced concrete bases are constructed from standard concrete with at least B 25 resistance class.

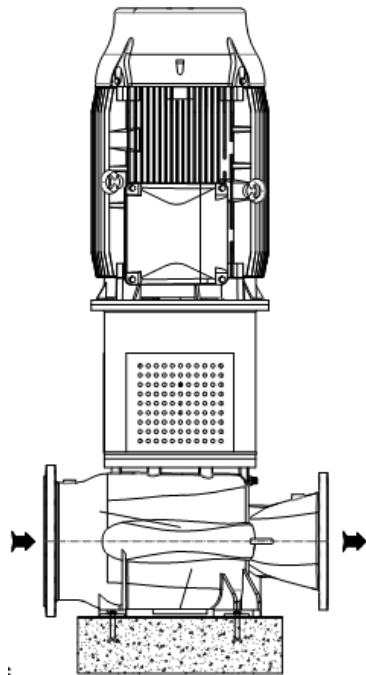
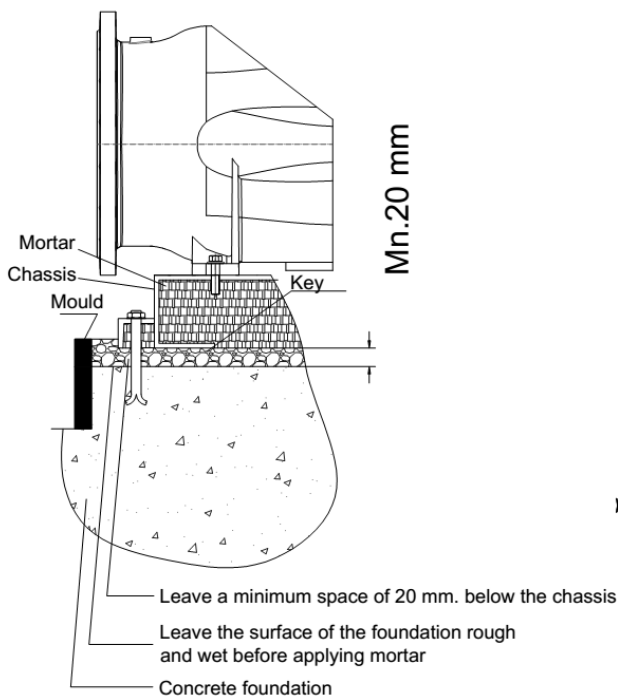

Figure 4: A Typical Concrete Foundation

In order to avoid overheating, vibration, noise and wearing of the rolling bearings, alignment of the coupling has to be made properly and checked often.
Do not use a different coupling other than the original type installed on pumping group.

6.4.2. Method of coupling alignment

In order to make the alignment of the coupling, it is required to have at least two pieces of about 10 cm tall, smooth-edged metal parts (e.g. a steel ruler or a gauge stick) and one precision calipers. (Figure 3) (For more precision alignments, special apparatus can be used).
Coupling misalignments in general are of two kinds:

1.Paralel Axis Misalignment (Figure 5)

In order to control parallel axis misalignment, a smooth edged gauge stick is pressed axially over the upper half of the coupling. Then, the gauge stick is checked for the other half of the coupling. For alignment, the gauge stick shall be in contact with both of the halves at the same time. This procedure shall be repeated for four sides of the coupling. (i.e. top, bottom, left and right sides of the coupling). When all four sides give reasonably accepted results, alignment of the coupling has been ensured.

2.Angular Misalignment (Figure 6)

In order to control the angular misalignment, the distance between the two halves of the coupling is measured in both horizontal and vertical planes. Measurements taken at four points shall be in agreement for the alignment.

Misalignments can be in horizontal or vertical planes. Misalignments in horizontal plane can be fixed by placing sheet iron at the bottom of the pump or motor base, while misalignments in vertical plane can be fixed by sliding the pump or the motor in horizontal plane.

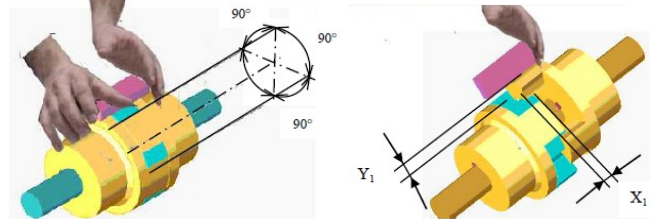

Figure 5: The Control of the Coupling Alignment in Horizontal and Vertical Planes

Figures below illustrate the possible coupling misalignments and the methods to correct them.

6.3.3. Fixing (Securing) of pump group

After the alignment of the pump group on the foundation has been made, the mutual securing bolt screws should be used alternately to fix the pump group.

6.4. Coupling alignment

6.4.1. General

For a proper operation of a pump group, a good alignment of the coupling is necessary. Vibration, noise, overheating of the bearings, overcharge problems can be attributed to the misalignment of coupling or using an improper coupling.

Flexible coupling does not correct the axial misalignments between the pump and the motor axes. However, it allows pinpointing the misalignments.

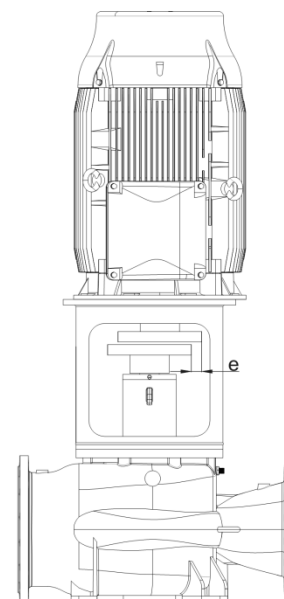

Figure 6: Parallel Axis Misalignment in Horizontal Plane and Its Correction

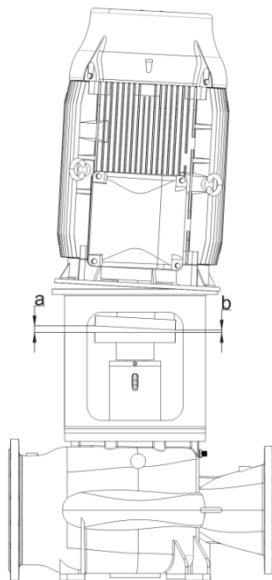

Figure 7: Angular Misalignment in Vertical Plane and Its Correction



Install the coupling guard only when the alignment of the coupling is checked.



According to accident prevention regulations, all the protections of the rotating parts and protective devices should be in place and operable.

6.5. Piping

6.5.1. General



- Do not use the pump as the hinged support for the piping system.
- Put enough supports under the piping system in order to carry the weight of the pipe and fittings.
- Avoid piping system loads on pump by installing flexible components (compensator) to suction and discharge of the pump.
- By mounting flexible supporting items, take into consideration the fact that these items may elongate under the pressure.
- Suction pipe shall be in a constantly increasing slope to the pump. Air in the suction pipe shall be arranged to move into the pump.
- Discharge piping shall be in a constantly increasing slope to the reservoir or discharge point, without up and downs which can cause air pockets in the piping system. At locations where forming of air pockets is possible, special items like air valve and air cock are mounted to evacuate the trapped air.
- It is important that pipe diameter and fittings are at least as much as the pump opening diameter or preferable one or two size higher. One should never use fittings with smaller diameters than the pump exit diameter. In particular, preferred fittings like foot valve, strainer, filter, check valves and valves shall have large free passing area, and low friction loss coefficient.
- For piping systems with hot liquids, thermal expansions are to be taken into account and compensators shall be mounted in accordance with these expansions. Caution shall be exercised to avoid the loading of pump in this installation.

6.5.2. Specification of Work in Piping Installation



In installation of pipes, follow the procedures below certainly.

- Install the pump on the concrete base as illustrated in Figure 3.
- Take out the guards (placed by the manufacturer) from suction and discharge openings of the pump.
- Close the suction and discharge flanges with rubber gaskets. This precaution is important to avoid the undesired substances (weld crust, weld slag, sand, stone, wood piece etc.) get into the pump. Do not take off this gasket until the installation is completed.
- Start the installation of piping from the pump side. Do the necessary assembling and welding of the parts in a successive order.
- In these operations, do not neglect to put the necessary supports in their respected locations.
- Following above procedure, complete all piping system at suction side up to the suction tank (or foot valve if available), at discharge side up to discharge collector and discharge pipe.
- When all installation and welding process is done and the heat dissipated by welding is removed, dismantle all the bolted connections from the suction tank to discharge pipe. Take out all demountable parts.
- Clean these parts and then paint body coat completely inside and outside.
- Mount the parts again in their intended places. However, this time start from the discharge line and move downward to the pump. In this instance, do not forget to check the flange gaskets. If needed, (for example deformation during welding) replace them.
- Concerning the connection of the pump flanges to piping, in case of misalignment of axis and flange holes, do not force the system to eliminate the misalignment. Forcing the system may cause difficult-to-correct problems.
- If there is an axial misalignment between the flanges of the pump and the pipe, due to the welding or any other reasons, cut the pipe from a suitable location in order to fix the problem. Connect the pipe (pump side) to the pump. After carrying out the necessary correction, connect the parts again by welding.
- Dismantle and clean the last welded part. Repaint again and mount on its place.
- After all these processes are accomplished, remove the rubber gasket from the suction and discharge openings. Open their holes and mount them again on their intended place.

6.5.3. Specification of Work after Installation of Piping and Piping System

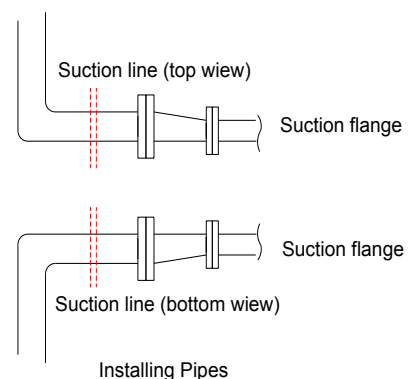

Figure 8: Piping System

An illustrative piping system is shown in Figure 10. Appropriate manometers shall be mounted on suction and discharge pipe lines.



Complete the auxiliary pipe connections in piping system if exist (cooling to bearing housing, and stuffing box (seal), relief pipe, oil pipe etc.)

6.6. Motor Connection

Motor shall be connected by an electrical technician according to the connection (switch) diagram. Local electricity policies regulations have to be applied.



- Electrical connections have to be made by authorized electricians.
- In dismantling the pump, make sure the electricity is cut off before taking the motor cover out.
- Use the appropriate electrical connection to the motor.

In environments where there is a risk of explosion, prescribed protective law and regulations shall be applied by competent authorities.

Connection points of the cable ends must be away from environment with explosion risk or provide allowable conditions for II 2G device category.



Never operate pump units not connected electrical cable connections correctly.

6.6.1. Motor Connection Diagram

Motors requiring high moments at start up shall not be connected star-delta

Frequency controlled motors, require high moment at start up and have to be cooled properly at low speeds. Provide the necessary cooling for the motors.

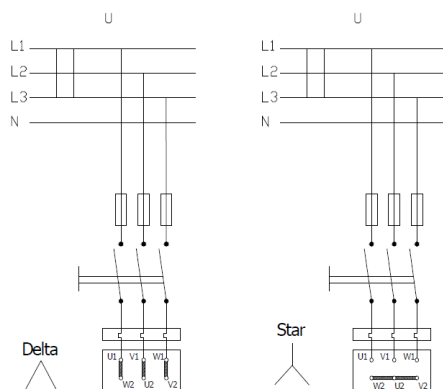

Figure 9: Electric Connection Diagram

Electrical Circuit	Motor	
U (Volt)	230/400 V	400 V
3 x 230 V	Delta	-
3 x 400 V	Star	Delta

6.6.2. Motor Protection

- Three phased-motor shall be connected to power supply.
- Wait the motor to cool down when thermic protected motor breaks in circuit due to the overheating. Make sure the motor does not start automatically until it cools completely
- In order to protect the motor from overcharging and short circuit use a thermic or thermic-magnetic relay. Adjust this relay to the nominal current of the motor.



Electrical equipments, terminals and the components of the control systems may carry electric current even though they are not operating. They may cause deadly and serious injuries or irreparable material damages.

7. COMMISSIONING, START UP AND OPERATING

7.1. Preparations Before Start Up

- Check pump seals
- Make sure that the pump and the suction pipe is completely filled with water before the starting. If the pump operates on a positive suction head, no problem will be encountered. Suction valve is opened and air drains are un-tightened.
- Pumps with foot valve are filled with water by opening the pump filling tap or, one takes advantage of the water accumulated in the discharge pipe and by using a small valve the check valve is bypassed and the pump is filled.
- In vacuum pump driven pumps, by operating the vacuum pump one achieves to fill the pump via increasing the water level in the suction pipe.



Do not start your pump dry (WITHOUT WATER).

7.2. Checking The Direction of Rotation



- The direction of rotation is indicated on the pump label with an arrow. Apart from special cases, it is clockwise direction when looking from the motor end. Observe if the pump is rotating in the expected sense by starting the motor for a very short instant. If it is turning in the opposite sense, interchange any of two motor leads.
- If the motor connection is delta, open the discharge valve slowly.
- If the motor connection is star-delta, set the time relay to maximum 5 seconds. Monitor the passage from star to delta by pressing the start button. As soon as you are assured that the connection is delta, open the discharge valve slowly. Continue opening the valve until you read the amperage on the electrical panel
- **One should always check the labels which show the direction of rotation and the direction of fluid flow. If you dismount the coupling protection to monitor the direction of rotation, do not restart the engine before remounting the protection.**



As a result of getting in touch with rotating and stable parts each other temperature increase can occur. Never check the direction of rotation while the pump is dry.

7.3. Start up Procedure

- Check if the suction valve is open and the discharge valve is closed. Start the motor
- Wait until the motor reaches sufficient speed. (In Star-delta connections, wait until the engine passes to delta connection.)
- Keeping an eye on the amperage shown on the panel, open the discharge valve slowly.

- In the primary operation, if the discharge pipe is empty, do not open the valve completely. By keeping an eye on the amperage, open the valve with care regarding that it should not exceed the value indicated on pump's label.
- After opening the valve completely, check the pressure from the pump exit manometer and make sure that this value is the pump operating pressure value and is indicated on pump's label.
- If the value one reads is less than the pump label value when the valve is completely open, it means that the height is miscalculated. Increase the value by narrowing the valve and bring it to pump's label value.
- If the value one reads is greater than the pump label value when the valve is completely open, it means that the height is calculated less than what it should be in reality. The device is pumping less than what is requested. Check the installation and the calculations.
- **Minimum flow rate:** If the pump is working with zero flow rates (closed valve) from time to time during its operation, the water inside the pump may endanger the pump by getting warmed up. In such cases, a minimum flow valve must be connected to the pump exit.



Stop the motor if the pump gets too hot. Wait until it gets cold. Then start the system up again carefully.

7.4. Shut Down Procedure



During sudden start ups and stops, a pressure reducing valve must be placed at the exit section of high flow rate pumps whose discharge pipelines are long, in order to reduce water hammer effect. Water hammer may explode the pump.

In normal conditions (apart from sudden power shut down, etc), stop the pump as below:

- Close the discharge valve slowly
- Switch the power off, stop the motor. Notice that the rotor slows down.
- Do not start up the motor at least before 1 to 2 minutes.
- If the pump will be out of use for a long time, close the suction valve and auxiliary circuits. If the pump is outside and if there exists a danger of frost, remove all drain taps and empty all the water inside the pump. (5.2. Storage)



If the pump is outside and if there exists a danger of frost, remove all drain taps and empty all the water inside the pump.

8. MAINTENANCE



Maintenance operations must be done by authorized personnel with protective clothing only. The personnel must also beware of high temperatures and harmful and/or caustic liquids. Make sure that the personnel read carefully the manual.

- The instructions in Safety Precautions must be executed during maintenance and repair
- Continuous monitoring and maintenance will increase the engine's and pump's lives.

The instructions below should be applied.

8.1. The Checks During the Operation

- Pump must never be operated without water.
- Pump must not be operated for a long time with the discharge valve closed (zero capacity).

- Precautions must be taken against flare up when the component temperatures are over 60°C. "Hot Surface" warnings must be placed over necessary areas.
- All the auxiliary systems must be in use while the pump is operating.
- If the pump has mechanical sealing, there is no need for excessive maintenance. Water leakage from the mechanical sealing indicates the fact that the sealing is worn out and therefore needs to be replaced.
- If the system consists of a substitute pump, keep it ready by operating it once a week. Check also the auxiliary systems of the substitute pump.



Occuring explosive ambient inside of the pump must be prevent. The air of the pump and suction line must be drained before commissioning of the pump. The interior of the pump contacting with pumped liquid including gasket way and auxiliary systems must be filled with pumped liquid.



- Ensure that delivery pressure is enough.
- Exceeded the allowable using limits regarding pressure, temperature, transporting material and motor speed may cause explosion risk, hot and poison liquid may leak to external environment.
- Do not operate the pump at values above pressure, temperature or motor speed values specified by manufacturer, never use improper liquids with the pump.

8.1.1. Component check



To make possible the visual control, one must be able to reach the pump from any direction. Especially, to be able to dismount the internal units of the pump and the engine, sufficient free space must be created around them for maintenance and repair. Furthermore, one must make sure that the piping system can easily be dismounted.

8.1.2. Bearing and lubrication

Bearing is provided with two grease lubricated, 6300 C3-type deep groove ball bearings in accordance to DIN 625. These bearings are maintenance should be performed periodically. The usual service life of the rolling bearings attains at least the operating hours indicated in the technical specifications of TS EN ISO 5199.

8.1.3. Mechanical seal

Mechanical seals are used in CSV series pumps. Mechanical Seals are absolutely leak tight and needs less maintenance than soft packing.

Mechanical seal;

1. Provides leak proof operation in heavy operating conditions (in waste water pumps, chemical process and refinery pumps).
2. Easily mountable and needs less maintenance.
3. Does not cause wearing on the shaft
4. Sealing operation does not depend on the quality of shaft finishing.

8.1.4. Drive

Apply to the operating instructions of the motor manufacturer.

8.1.5. Auxiliary components

Check regularly the fittings and the gaskets, replace the worn out pieces.

8.2. Maintenance Instructions in ATEX Version Pumps

- Consider the local safety instructions and ATEX version pump label specifications.
- During maintenance or repair by taking sparking into consideration, maintain or repair in environments where there is no a possibility of ignition.
- As a result of maintaining deficiently and / or faultily the pump may be damaged and explosion risk may occur. Maintain the pump or the pump unit regularly.
- Carry out maintenance the shaft sealing components properly and regularly. Hot or toxic pumped liquid may leak from the sealing components not maintained regularly. In this case, the damage to the pump, fire and explosion hazards are the likely consequences.
- Fire or explosion hazards may occur as a result of overheating in bearing housings or faulty bearing housing gaskets. Because of that, check the level of lubrication element and periods of lubrication regularly. Check the sounds come from the bearings during the running regularly.

8.3. Service

Our Customer Service Department offers after-sale service. Manager should employ authorized and trained personnel for mounting/dismounting procedures. Before these procedures, one must make sure that pump interior is clean and empty.

This criterion is also valid for the pumps which are sent to our factory or to our service points.



Maintain the safety of the personnel and the environment in every field procedure.

8.4. Spare Parts

The spare parts of CSV type pumps are guaranteed for **10 years** by **MAS DAF MAKINA SANAYI A.Ş.**

In your spare parts requests, please indicate the below listed values that are indicated on your pump's label.

Pump type and size:

Motor power and speed:

Pump serial number:

Capacity and head:

If you wish to keep spare parts in store, depending on the number of same type of pumps, for two operation years, the quantities which are listed in the table below are recommended.

Component Name	The Number of Equivalent Pumps in the Installation						
	1-2	3	4	5	6-7	8-9	10+
Shaft (Key included) (quantity)	1	1	2	2	2	3	%30
Impeller (quantity)	1	1	1	2	2	3	%30
Mechanical Seal	1	2	2	3	3	4	%50
Wear ring	1	1	1	2	2	3	%50
Coupling	1	2	2	3	3	4	%50
O-Rings for Casing (quantity + 1)	1	1	1	2	2	3	%40

Table 1: Spare Part List

9. NOISE LEVEL AND VIBRATION

The reasons which increase the noise level are indicated below:

- Touch of coupling halves due to worn rubber sleeves (incorrectly aligned)
- Noise level increases due to the fact that the pump is not founded properly (Vibration)
- If the installation does not have compensator noise and vibration increases.
- Wearing in ball bearing also increases noise level.



Check if there is any noise increasing elements in your installation.

9.1. Expected Noise Values

- The distance between the measure point and the pump : 1m
- Operation : Without Cavitation
- Motor : IEC Standard Motor
- Tolerance : ±3 dB

Power of Motor PN [kW]	Sound Pressure Level [dB] *	
	Pump with Motor	
	1000 rpm	1500 rpm
22	61	-
30	62	-
37	64	-
45	65	-
55	65	-
75	72	67
90	72	67
110	-	74
132	-	74
160	-	74
185	-	74
200	-	74
250	-	75

Table 2: Sound Pressure Level

(*) Without protective sound hood, measured at a distance of 1 m directly above the driven pump, in a free space above a sound reflecting surface.

The above values are maximum values. The surface noise pressure level at dB(A) unit is shown as (L_{pA}). This complies with TS EN ISO 20361.

10. DISASSEMBLY, REPAIR AND REASSEMBLY



Before starting work on the pump set, make sure it is disconnected from the mains and can not be switched on accidentally.

Follow the safety precautions outlined in "Safety instructions".

10.1. Disassembly

- Close all valves in the suctions and discharge lines. Drain the water in the pump.
- Remove the safety guard.
- Because of the pump design, the impeller, shaft and other rotating parts being removable no need to disconnect the suction and delivery pipes. If there is not any operation on the casing, not need to remove the pipe connection.
- If to take out the complete pump is necessary, disconnect pump from the driver, suction and discharge pipes and detach the baseplate (if Any)
- Take out the stud nuts (300) which connect the adapter to the casing and disconnect the rotor assembly with the motor from the volute casing.
- Unscrew impeller nut (362) and take out the impeller (20) by using suitable pull-off device or crank. Use rust remover solvent during dismantling if necessary.
- Take out the coupling and other security casing by unscrew setscrews on the coupling and take off the motor from the rotor assembly by unscrew the hex bolts (320).
- Pull out the rotating part of the mechanical seal (250) from the shaft.
- Take out the shaft.

10.2. Reassembly

- Reassembly proceeds in reverse sequence to disassembly as described in section 10.1. You may find the attached drawings useful.
- Coat the seats and screw connections with graphite, silicon or similar slippery substance before reassembly. If you can not find any of the above you may use oil instead. (Except the pumps for drinking water)
- Never use the old o-rings and make sure the o-rings are the same size as the old ones.
- Connect the pump shaft to the coupling and motor, fix the setscrews.
- Place the stationary part of mechanical seal to its place on the adapter.
- Mount the adaptor to the motor flange.
- Slip the rotating part of the mechanical seal onto the pump shaft.
- Place the impeller key into keyway, slide the impeller onto the shaft and screw the impeller nuts.
- Now reassembly of the rotor group is completed.
- Finally mount rotor assembly to the volute casing. (In the repair shop or on site)
- Make sure the gaskets and o-rings are evenly placed without sliding and not damaged or not squeezed at all.
- Place the pump on the baseplate, couple the motor. Connect suction and discharge pipes as well as auxiliary pipes. Take the unit into operation as it was indicated in section 7.



Check whether the faces contacting with another faces are damaged for avoiding explosion before reassembling of the motor. The parts having deformed faces must be replaced. Ensure that the rotating parts are fitted with the guards.

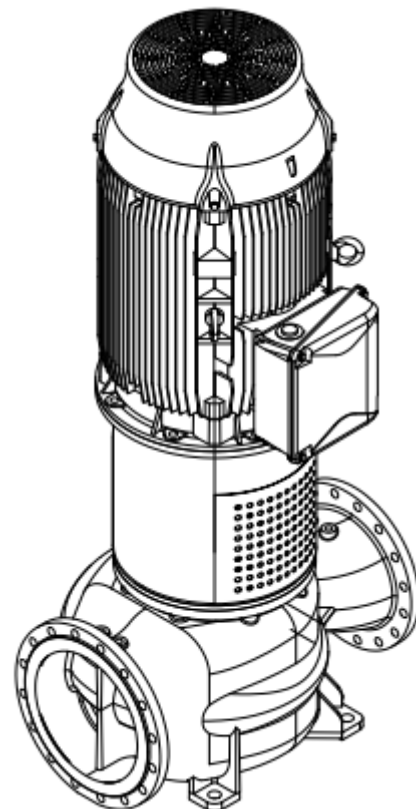

11. POSSIBLE FAILURES, CAUSES, SOLUTIONS

Possible failures and solution strategies are listed in the table below. Please apply to the Customers' Service Department of our company when a generic solution is not found to your problem.



While the failures are repaired the pump must always be dry and un-pressurized.

POSSIBLE FAILURE	CAUSES	SOLUTIONS
The pump delivers insufficient capacity	<ul style="list-style-type: none"> Discharge head too high Very high counter pressure Pump and/or pipe cannot discharge air, cannot suck Occurrence of air pockets inside the pipe NPSH is too low 	<ul style="list-style-type: none"> Readjust the operating point See if there is any undesired material inside the pipe Vent completely the pump and the pipe Change the piping configuration Increase the liquid level
Motor overload	<ul style="list-style-type: none"> System pressure is lower than the requested pressure level Speed too high Liquid pumped of different specific gravity and viscosity than that for which pump is rated Engine works at two phases 	<ul style="list-style-type: none"> Adjust the operating pressure to the label value Decrease the speed Increase the engine power Replace the fuse and control the electrical connections
Pump head is too high	<ul style="list-style-type: none"> System pressure is higher than the requested pressure level 	<ul style="list-style-type: none"> Set the operating pressure to the label value.
Bearing temperatures are high	<ul style="list-style-type: none"> Worn out or misaligned coupling Too much, too little or improper lubrication Increase in axial forcing 	<ul style="list-style-type: none"> Replace the coupling or align it Change the oil, decrease or increase its quantity Clean the balance holes on the impeller disc
Excessive leakage from the stuffing box	<ul style="list-style-type: none"> Worn out gland 	<ul style="list-style-type: none"> Use brand new gland Change the stuffing bush
Noisy operation	<ul style="list-style-type: none"> Worn out motor or pump ball bearings Cavitation Worn out or misaligned coupling Operation in the far left or right of the performance curve 	<ul style="list-style-type: none"> Replace Close the delivery partially in order to reduce the capacity. Replace the coupling or align it Operate the pump at its label setting
Excessive increase in pump temperature	<ul style="list-style-type: none"> Pump and/or pipe can neither discharge, nor aspirate air Too low capacity 	<ul style="list-style-type: none"> Bleed completely the pump and the pipe Open more the valve
Vibration	<ul style="list-style-type: none"> Pump and/or pipe can neither discharge, nor aspirate air NPSH is too low Internal components of the pump are worn out System pressure is lower than the requested pressure level Coupling is misaligned Too much, too little or improper lubrication Rotor unbalanced Improper bearings 	<ul style="list-style-type: none"> Bleed completely the pump and the pipe Increase the liquid level Replace the worn out components Adjust the operating pressure to the label value In case of continuous overload, decrease the impeller diameter Align the coupling Change the oil, decrease or increase its quantity Balance the impeller again Use new bearings

Table 3: Possible Failures, Causes, Solutions

12.PUMP DIMENSIONS TABLE

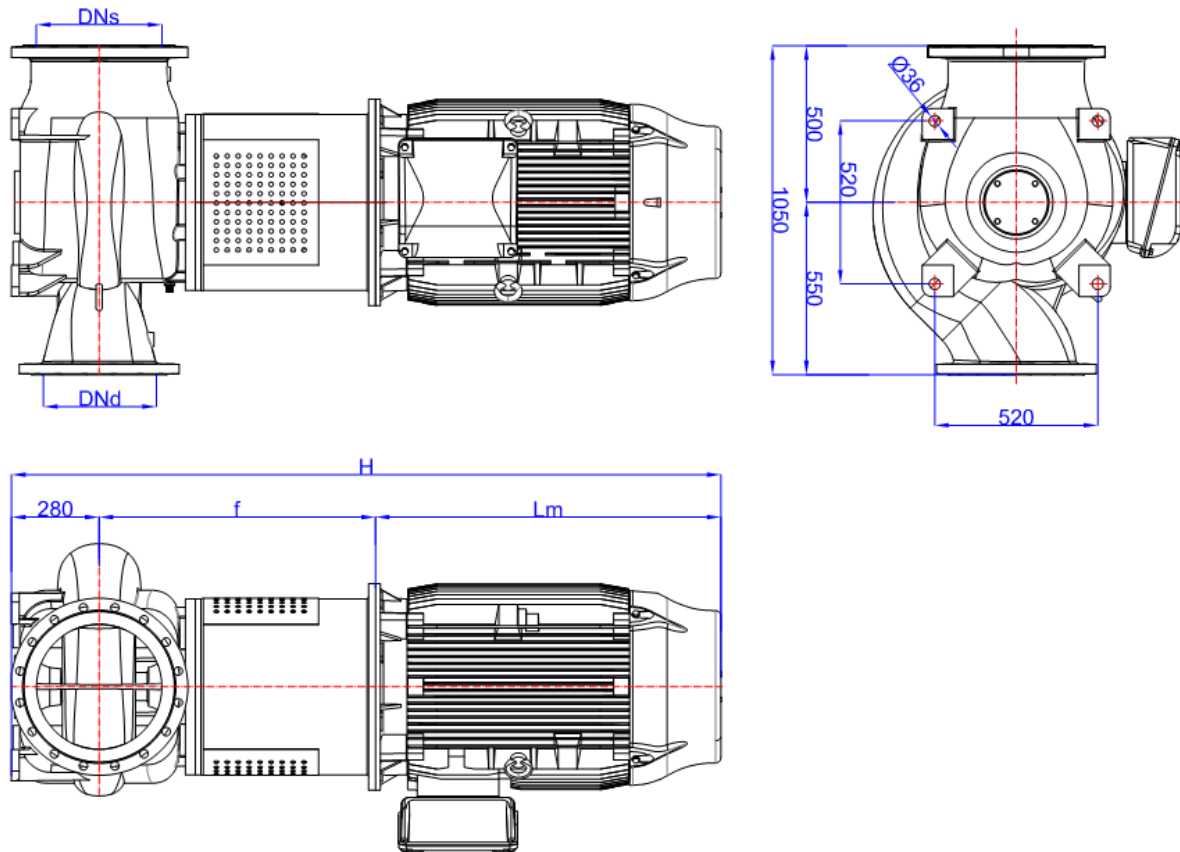

Figure 10: CSV Pump Dimensions Figure

Motor Type	Motor Power (kW)	DNs	DNd	f	Lm	H
200L	22	DN 400 PN 10	DN 350 PN 10	825	640	1745
225M	30			825	680	1785
250M	37			855	755	1890
280S-280M	45-55			855	820	1955
315S-315M	75-90			855	980	2145

Table 4: CSV Pump Dimensions Table (1000 rpm)

Motor Type	Motor Power (kW)	DNs	DNd	f	Lm	H
280S-280M	75-90	DN 400 PN 10	DN 350 PN 10	855	820	1955
315S	110			885	980	2145
315M	132-160			885	980	2145
315L	185-200			885	1050	2215
315L	250			885	1050	2215

Table 5: CSV Pump Dimensions Table (1500 rpm)

13.SAMPLE PLUMBING

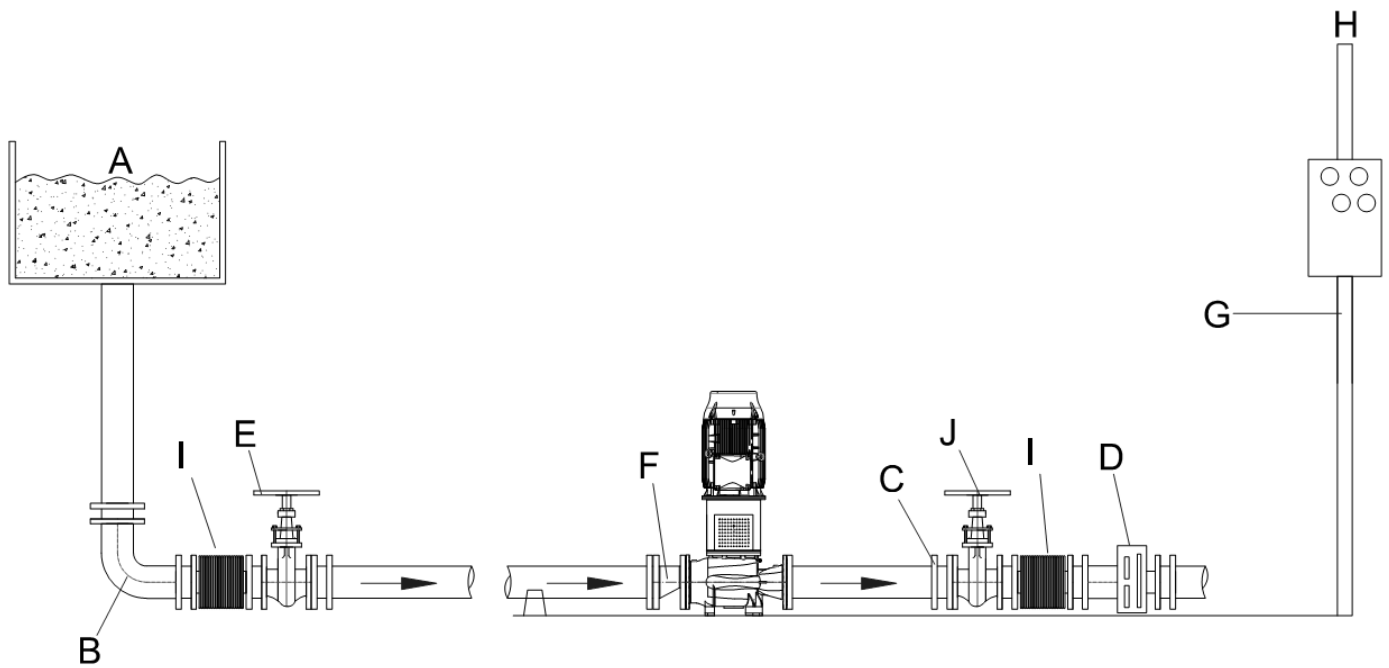
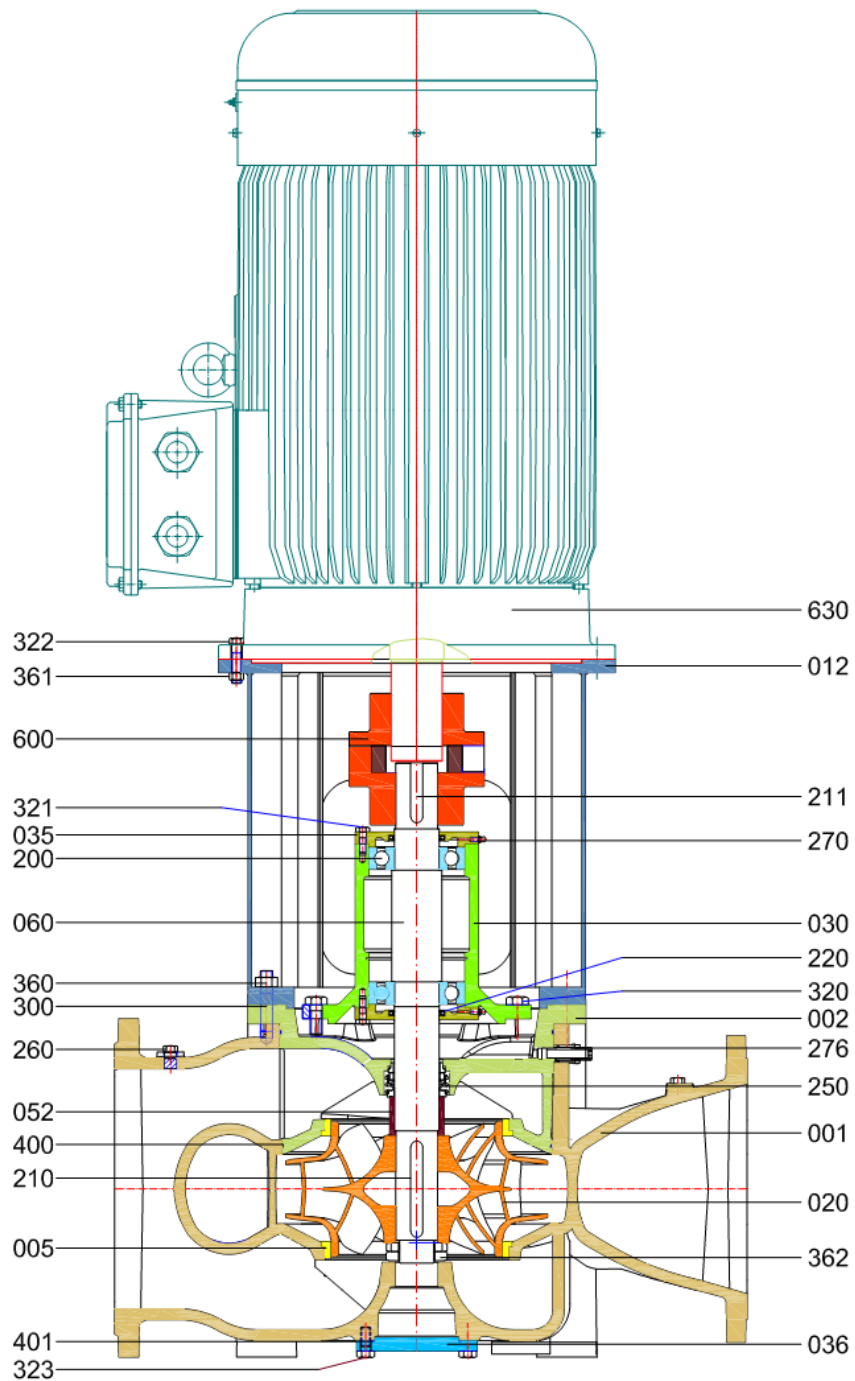

Figure 11: Sample Plumbing

- A. Tank
- B. Elbow
- C. Adapter
- D. Non-return valve
- E. Suction valve
- F. Reducer
- G. Electrical Connection
- H. Insulated Cable
- I. Compensator
- J. Discharge valve

14.CSV SECTIONAL DRAWING AND PARTS LIST

Figure 12: CSV Sectional Drawing

Part No	Part Name	Part No	Part Name	Part No	Part Name
01	Volute Casing	200	Bearing	321	Hex Bolt
02	Top Cover	210	Impeller Key	322	Hex Bolt
05	Wear Ring	211	Coupling Key	323	Hex Bolt
12	Adapter	220	Oil Seal	360	Nut (Casing)
20	Impeller	250	Mechanical Seal	361	Nut (Motor)
30	Bearing Housing	260	Solid Plug	362	Nut (Puller)
35	Bearing Cover	270	Greaser	400	O-Ring
36	Bottom Cover	276	Valve	401	O-Ring
52	Mech.Seals Front Bushing	300	Casing Stud	600	Coupling Kit
60	Shaft	320	Hex Bolt	630	Motor

Table 6: CSV Sectional Part List

15.FIGURE LIST

Page No

Figure 1	Pump Label	2
Figure 2	ATEX Version Pump Label	2
Figure 3	Transport of Pump Group	4
Figure 4	A Typical Concrete Foundation	5
Figure 5	The Control of the Coupling Alignment in Horizontal and Vertical Planes	5
Figure 6	Paralel Axis Misalignment in Vertical Plane and Its Correction	5
Figure 7	Angular Misalignment in Vertical Plane and Its Correction	6
Figure 8	Piping System	6
Figure 9	Electric Connection Diagram	7
Figure 10	CSV Pump Dimensions Figure	12
Figure 11	Sample Plumbing	13
Figure 12	CSV Sectional Drawing	14

16.TABLE LIST

Page No

Table 1	Spare Part List	9
Table 2	Sound Pressure Level	9
Table 3	Possible Failures, Causes, Solutions	11
Table 4	CSV Pump Dimensions Table (1000 rpm)	12
Table 5	CSV Pump Dimensions Table (1500 rpm)	12
Table 6	CSV Sectional Part List	14



Head Office / Center Service:

Aydınlı Mah. Birlik OSB. 1.No'lu Cadde No:17 Tuzla - İSTANBUL / TURKEY
Tel: +90 (216) 456 47 00 pbx Fax: +90 (216) 455 14 24

Ankara Regional Directorate:

Aşağı Öveçler Mah. 1329 Sok. No:6/9 Öveçler ANKARA / TURKEY
Tel: +90 (312) 472 81 60-67 Fax: +90 (312) 472 82 51

Factory:

1. Organize Sanayi Bölgesi Parsel 249/5 Beyköy - DÜZCE / TURKEY
Tel: +90 (380) 553 73 88 Fax: +90 (380) 553 71 29