

In-Line Centrifugal Pumps with Frequency Inverter

GENiO INM SERIES



OPERATING MANUAL





EC DECLARATION OF CONFORMITY

AT UYGUNLUK BEYANI

Manufacturer / İmalatçı : MAS DAF MAKİNA SANAYİ A.Ş.

Address / Adres : Aydınli Mah. Birlik OSB. 1.No'lu Cadde No:17 Tuzla - İSTANBUL / TÜRKİYE

Name and address of the person authorised to compile the technical file : Vahdettin YIRTMAÇ
Aydınli Mah. Birlik OSB. 1.No'lu Cadde No:17
Teknik Dosyayı Derleyen Yetkili Kişi ve Adresi : Tuzla - İSTANBUL / TÜRKİYE

The undersigned Company certifies under its sole responsibility that the item of equipment specified below satisfies the requirements of the mainly Machinery Directive 2006/42/EC which is apply to it.

The item of equipment identified below has been subject to internal manufacturing checks with monitoring of the final assessment by MAS DAF MAKİNA SANAYİ A.Ş.

Aşağıda tanımlanmış olan ürünler için Makine Emniyeti yönetmeliği 2006 / 42 / AT' nin uygulanabilen gerekliliklerinin yerine getirildiğini ve sorumluluğun alınmış olduğunu beyan ederiz.

Aşağıda tanımlanan ürünler içüretim kontrollerine bağılı olarak MAS DAF MAKİNA SANAYİ A.Ş. tarafından kontrol edilmiştir.

Equipment / Ürün : In-Line Centrifugal Pumps / In-Line Santrifüj Pompalar

Seri / Model-Tip : INM / INL Series - INM / INL Serisi

For pumps supplied with drivers/ Elektrikli Pompa Üniteleri Related Directives / Yönetmelikler

2006/42/EC Machinery Directive / 2006/42/AT Makine Emniyeti Yönetmeliği

2014/35/EU Low Voltage Directive / 2014/35/AB Alçak Gerilim Yönetmeliği

2014/30/EU Electromagnetic Compatibility Directive / 2014/30/AB Elektromanyetik Uyumluluk Yönetmeliği

EUP 2009/ 125 /EC Electric Used Products Directive/ Elektrik Kullanan Ekipmanlar Direktifi (EUP)

94/9/EC Equipment For Explosive Atmospheres / Patlayıcı Ortamlardaki Ekipman Yönetmeliği

2009/125/EC European Ecodesign Directive, Regulation No: 547/2012 Ecodesign Requirements for Water Pumps / Avrupa Ekotasarım Direktifi, (SGM-2015/44) 547/2012 No'lu Su Pompalarında Ekotasarım Regülasyonu

Regulations applied acc. to harmonize standards / Uygulanan Uyumlaştırılmış Standartlar

TS EN ISO 12100:2010, TS EN 809+A1, TS EN 60204-1:2011.

We hereby declare that this equipment is intended to be incorporated into, or assembled with other machinery to constitute relevant machinery to comply with essential health and safety requirements of Directive The machinery covered by this declaration must not be put into service until the relevant machinery into which it is to be incorporated has been declared in conformity with provisions of the directive.

Ekipman, uygun bir makina oluşturmak amacıyla diğer ekipmanlar ile birleştirilirken ya da monte edilirken gerekli sağıık ve güvenlik yönetmeliklerine uyulması gerekmektedir.

Bu bildiri kapsamında yönetmelikte belirtilen bütün hükümler yerine getirilmeden makinanın devreye alınması gerekmektedir.

Place and date of issue / Yer ve Tarih : İstanbul, 02.06.2014

Name and position of authorized person : Vahdettin YIRTMAÇ
Yetkili Kişinin Adı ve Görevi : General Manager / Genel Müdür

Signature of authorized person :
Yetkili Kişinin İmzası

TABLE OF CONTENTS	Page No
Introduction	1
1.Important Safety Precautions	1
2.General	1
3.Safe Operating Conditions	2
4.Technical Information	3
5.Transport and Storage	3
6.Assembly/Installation	4
6.1.Location of Installation	4
6.2.Piping	4
6.3.Motor Connection	4
7.Commissioning, Start up and Operating	5
7.1.Preparations Before Start up	5
7.2.Checking The Direction of Rotation	5
7.3.Start up Procedure	5
7.4.Shut Down Procedure	5
8.Maintenance	6
8.1.The Checks During the Operation	6
8.2.Service	6
8.3.Spare Parts	6
9.Noise Level and Vibration	7
10. Disassembly, Repair and Reassembly	7
11. Information About Frequency Inverter	8
12. Possible Failures, Causes, Solutions	14
13. Pump Dimensions Table	15
14. Tightening Torques	22
15. Forces And Moments at The Pump Flanges	23
16. Sample Plumbing	24
17. INM/INL Sectional Drawing and Part List	25
18. INM Drawing for Dismantling	28
19. INM/INL Series MEI Value Tables	30
20. Figure List	31
21. Table List	31

1. IMPORTANT SAFETY PRECAUTIONS

In order to minimize the accidents during the mounting and putting into service of the pump, the following rules have to be applied:

1. Do not work without taking safety measures relevant to equipment. Cable, mask and safety band must be used when necessary.
2. Be sure there is adequate amount of oxygen and there is no toxic gaseous around
3. Before using welding or any electrical equipment make sure that there is no risk of explosion.
4. Check the cleanliness of the area to take care of your help. (Dust, smoke, etc.)
5. Do keep in mind that there is a risk of having accidents related to electricity
6. Do not lift the pump before you check the transport equipment.
7. Be sure you have a by-pass line
8. Use helmet, eye glasses and protective shoes for your safety
9. Place a protective barrier around the pump within the necessary safety area
10. Dust, liquids and gaseous that may cause overheating, short circuit, corrosion and fire must be kept away from the pump unit.
11. By checking the noise level of the pump unit, necessary measures to avoid noisy operation of the pump that can have harmful effects on the personnel and environment.
12. Be careful about the direction of transport and storage.
13. Cover appropriately the moving parts to avoid possible injury of the personnel. Mount the coupling guard and belting before starting-up the pump
14. All the electrical and electronic applications must be performed by authorized person conforming EN60204-1 and /or domestic instructions.
15. Protect the electrical equipment and motor against overloading
16. If flammable and explosive liquids are pumped, ground connection of electricity should be carried out properly
17. Do not expose the pump unit to sudden temperature variations
18. All personnel who work with the waste water system need to be vaccinated in case of contagious diseases.
19. If the pump contains hazardous liquids, one must use protective helmet against the risk of splatter. One also must accumulate the liquid in a proper container against any risk of leakage.

All Other Health and Safety Rules, Laws and Regulations Must Be Applied

2. GENERAL

2.1. Definition of Pump and Usage Areas

INM/INL series pumps are non-self priming in-line centrifugal pumps.

They are used in

- Water networks and pressurization facilities
- Irrigation, sprinkling and drainage systems
- Filling-Draining of tanks and reservoirs
- Hot and cold water circulation in heating and cooling systems
- Condense water pumping
- Water circulations in pools
- Health and purification facilities
- Industrial and social facilities
- Fresh and sea water pumping in ships

They shall be used to pressurize liquids (up to 90°C) which are clean or mildly impure, non abrasive, and not containing large solid particles or fiber.



Please contact MAS DAF MAKINA SANAYI A.Ş. for liquids that have different chemical and physical specifications.

INM/INL pumps comply with DIN 24255 standards within nominal capacity range.

INTRODUCTION



- This manual contains instructions for the installation, operation and maintenance of the INM/INL type non-self priming in-line centrifugal pumps of **MAS DAF MAKINA SANAYI A.Ş.**
- Please read carefully this manual and apply all the instructions to operate pumps without problems. Pumps shall be used for their intended duties. In this manual, there are information on operating conditions, installation, starting-up, settings and main controls of pumps.
- These operating and maintenance instructions contain **MAS DAF MAKINA SANAYI A.Ş.**'s suggestions. The special operating and maintenance information of the plumbing that a pump is fitted to is not considered in these instructions. This information must be given by the plumbing constructors only.
- **Please refer to instructions of plumbing constructors.**
- Please pay attention to the warnings in this manual and ensure that it is read before the installation-start up process. **MAS DAF MAKINA SANAYI A.Ş.** is not responsible for the accidents resulting from negligence.
- If you cannot find an answer to your questions in this manual, it is suggested that you contact **MAS DAF MAKINA SANAYI A.Ş.** Please inform us about the rated value and especially the serial number of the pump when you get in contact for help.
- The safety instructions in this manual cover the current national accident protection regulations. Beside all of these, an operation, work and safety measure imposed by the costumer has to be applied.

The Signs Used in This Operation Manual



Read the instructions carefully in this operating manual and keep it for your future reference.



Warning sign against the electrical risks



Sign for the operator's safety.



Sign for protecting against explosion.

Technical specifications of INM/INL type pumps

Suction Flange:	DN 40-DN 250
Discharge Flange:	DN 40-DN 250
Operating Pressure:	10 bar.
Operating Temperature:	-25 – 120°C
Capacity:	2-800 m ³ /h
Hm:	2-100 m.
Speed:	900-3600 RPM

Product Information as per Regulation No. 547/2012 (for Water Pumps with a Maximum Shaft Power of 150 kW) Implementing "Ecodesign" Directive 2009/125/EC

Minimum Efficiency Index for MAS INM/INL Pump Series is shown on the pump label.

MEI values of MAS INM/INL Pump Series are shown on the pump characteristic curves.

Minimum Efficiency Index for MAS INM/INL Pump Series; Minimum 0.4. (MEI≥0,4)

Efficiency values of the pump characteristic curves, which are cut diameter, are expressed in %.

INM/INL Series water pumps, the pump efficiency can be achieved more than fix speed in case of variable speed control.

More information about the Ecodesign can be reached at www.europump.org

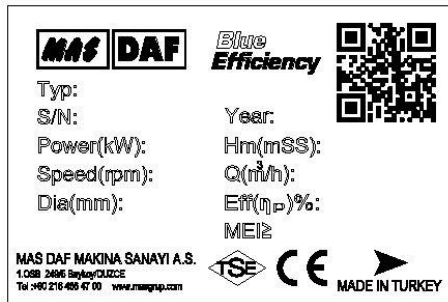

Figure 1: Pump Label

2.2. Performance Information

Actual performance of the pump can be obtained from the order page and/or from the test report. This information is given on the pump label. The performance curves given in the catalog are valid for water whose density and viscosity are $\rho=1 \text{ kg/dm}^3$ and $\nu=1 \text{ cst.}$ respectively. For those liquids whose densities and viscosities are different from those of water, please consult with **MAS DAF MAKINA SANAYI A.Ş.** since the performance curves vary with density and viscosity



Do not operate the pump with a motor that has a different power except for the given catalog and label values.

The pump is not to be operated at off-design point given in the order and supplied from the firm. It is necessary to ensure that the instructions are obeyed for the safe running of the pump.

2.3. Warranty Conditions

The entire products in our selling program are warranted by **MAS DAF MAKINA SANAYI A.Ş.**

The warranty conditions will only be valid when all the instructions about installation and start-up operations of the pump unit are taken into account.

2.4. Test

All Pumps are dispatched for sale when all the performance and pressure tests are completed. Proper assurance of material and fault-free operation of pumps whose performance tests are made is under the warranty of **MAS DAF MAKINA SANAYI A.Ş.**

2.5. Pressure Limit



Pressure at the discharge flange must not exceed 16 Bar. A special order is necessary for applications with higher pressures.

3. SAFE OPERATING CONDITIONS

This manual contains main safety instructions for the installation, operation and maintenance. It must be read by the personnel who are responsible for installation and operation. This manual should always be kept near the installation location. It is important to comply with safety precautions stated in page 1 along with the general safety instructions as well as preventive measures repeated in other sections of this manual.

3.1. Training of Personnel

Installation, operation and maintenance personnel must have necessary knowledge in order to accomplish the given job. The responsibility, adequacies and controlling duties of such personnel must be determined by the customer. It has to be certain that these personnel comprehend totally the content of the operating manual. If the personnel do not have enough knowledge, required training must be given by the customer. If training support is needed by the customer, it will be provided by the manufacturer/seller.



Untrained personnel and unwillingness to comply with safety instructions may be risky for both machine and environment. **MAS DAF MAKINA SANAYI A.Ş.** is not responsible for this kind of damages.

3.2. Hazardous Conditions That May Occur When One does not Comply With the Safety Instructions

Incompliance with safety regulations may put the personnel, the environment and the machine in danger and thus may cause damages. Incompliance with safety regulations may give rise to situations listed below.

- Important operational functions of the factory may stop.**
- Maintenance may get difficult.**
- One may get injured by electrical, mechanical or chemical hazards.**

3.3. Safety Measures for Operator

Dangerous, hot or cold components in the pump area must be covered so that one cannot touch them. Moving components of the pump (such as coupling) must be covered so that one cannot touch them. Those covers must not be dismantled while the pump is running. Dangers that results from electrical connections must be removed. To get more information about this subject, you can refer to domestic electrical instructions.

3.4. Safety Measures for Maintenance and Installation

The customer must assure that all maintenance, check and installation tasks are performed by qualified personnel. Repair work must only be performed while the machine is not running.

The pump and its auxiliary system must be cleaned thoroughly if it contains hazardous liquids. At the end of the repair work, all safety and protective equipment must be re-installed.

3.5. Spare Parts Replacement

Replacement of spare parts and all modifications must be done after contacting with the manufacturer. Spare parts and accessories certified by the manufacturer are important for the safe operation of the system.

Notice: MAS DAF MAKINA SANAYI A.Ş. is not responsible from the usage of improper spare parts.

4. TECHNICAL INFORMATION

4.1. Design

Single stage, non-self priming in-line centrifugal pumps are furnished with standard pumps and mechanical sealings.

4.1.1. Locations of Flange – Flanges

Discharge Flanges : DIN 2533-PN 16
Suction Flanges : DIN 2533-PN 16

4.1.2. Connection of Pump and Motor

Motor is close coupled to the pump with a rigid coupling using an adapter and flange. In this way, the shafts of the motor and pump constitute a complete unit.

4.1.3. Impeller

The closed radial type impeller of the pump is balanced dynamically in an electronic balance machine. The thrust (axial force) is balanced with the back wear ring and balance holes.

4.1.4. Shaft

The shaft, impeller and other parts of the pump is designed to be dismountable without moving (dislodge) the suction and discharge pipes and volute of the pump. In this way, the installation and maintenance operations can be performed very easily.

4.1.5. Bearing and Lubrication

Rolling bearings are not used in INM type pumps. Motor bearing is enough for countervailing all axial and radial forces.

4.1.6. Seals

In standard production, various mechanical seal types (e.g. bellow type, spring actuated type) are used for sealing.

4.2. Construction of Pump Group

4.2.1. Drive

TEFC (Totally Enclosed Fan Cooled) 3 phase, squirrel caged, in accordance to DIN 42673, IM 2001B5 type electrical motor which complies with DIN IEC and VDE is used to drive the pump in proper speed and power.

Specifications of electrical motor;

Isolation class: F
Protection class: IP 54-IP 55
Frequency: 50 Hz
Running type: S1
Start up type: Up to 4 kW, 3x380 V (Y)
More than 4 kW, 3x380V (Δ)+(Y/Δ)

4.2.2. Coupling and Coupling Guard

At INM type pumps, a flexible coupling is used. A coupling guard is given in accordance with EN 953.



Pump can only be run with a coupling guard in accordance with EN 953 according to safety instructions.

If there is no coupling cover, it is provided by the operator.

5. TRANSPORT AND STORAGE

Suction, discharge and all auxiliary fittings must be closed during transport and storage. Dead-end covers must be removed while the pump unit is being installed.

5.1. Transport

Pump and pump group must be carried safely to the installation location by lifting equipments.



Current general lifting safety instructions must be applied. Please use a suspension system shown in figure while you are carrying and lifting the pump unit. The suspension rings may be broken because of the excessive load and may result in a damage of the pump. Prefer fabric cable for suspension.

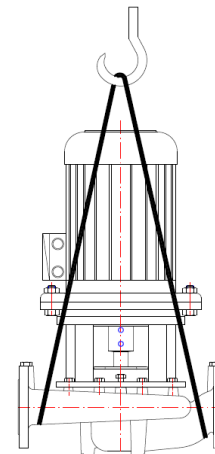

Figure 2: Transport of Pump Group



Incorrect lifting may damage the pump unit and cause injuries.

Damages caused in transport

Check the pump when it is delivered to you. Please let us know if there is any damage.

5.2. Storage



Please keep the unit clean and dry area during storage.

If the pump is out of use for a long time, please consider the instructions below.

1. If there is water inside the pump, drain it.
2. Clean the pump casing and impeller by jetting clean water for a short time.
3. Empty water inside the pump casing, suction line and discharge line.

4. Add small amount of antifreeze inside the pump casing if it is not possible to empty it completely. Rotate the pump shaft by hand to mix the antifreeze.
5. Close the suction and discharge exits with gasket
6. Spray an anti-corrosive into the pump casing.
7. Rotate the pump shaft by hand once in every month, in order to protect it from freezing and to lubricate the bearings.

6. ASSEMBLY / INSTALLATION

In our standard production, the pump and the motor have been installed in a common base plate.

6.1. Location of Installation

Pump shall be installed in a location where the control and the maintenance of the pump are easily made. The pump room shall be suitable for operation of lifting systems such as freight elevator, forklift, etc.

The pump group should be installed in the lowest possible location of the pumping system in order to achieve the highest suction pressure.

6.1.1. Location of Installation- Local Ambient Temperature

When the local ambient room temperature exceeds +40°C in a pumping system, suitable ventilation should be provided in order to remove the heat dissipated to the environment and supply fresh air.

6.2. Piping

6.2.1. General



- Do not use the pump as the hinged support for the piping system.
- Put enough supports under the piping system in order to carry the weight of the pipe and fittings.
- Avoid piping system loads on pump by installing flexible components (compensator) to suction and discharge of the pump.
- By mounting flexible supporting items, take into consideration the fact that these items may elongate under the pressure.
- Suction pipe shall be in a constantly increasing slope to the pump. Air in the suction pipe shall be arranged to move into the pump
- Discharge piping shall be in a constantly increasing slope to the reservoir or discharge point, without up and downs which can cause air pockets in the piping system. At locations where forming of air pockets is possible, special items like air valve and air cock are mounted to evacuate the trapped air.
- It is important that pipe diameter and fittings are at least as much as the pump opening diameter or preferable one or two size higher. One should never use fittings with smaller diameters than the pump exit diameter. In particular, preferred fittings like foot valve, strainer, filter, check valves and valves shall have large free passing area, and low friction loss coefficient.
- For piping systems with hot liquids, thermal expansions are to be taken into account and compensators shall be mounted in accordance with these expansions. Caution shall be exercised to avoid the loading of pump in this installation.

6.2.2. Specification of Work in Piping Installation



In installation of pipes, follow the procedures below certainly.

- Install the pump on the concrete base as illustrated in Figure 2.
- Take out the guards (placed by the manufacturer) from suction and discharge openings of the pump.
- Close the suction and discharge flanges with rubber gaskets. This precaution is important to avoid the undesired substances (weld crust, weld slag, sand, stone, wood piece etc.) get into the pump. Do not take off this gasket until the installation is completed.

- Start the installation of piping from the pump side. Do the necessary assembling and welding of the parts in a successive order.
- In these operations, do not neglect to put the necessary supports in their respected locations.
- Following above procedure, complete all piping system at suction side up to the suction tank (or foot valve if available), at discharge side up to do discharge collector and discharge pipe.
- When all installation and welding process is done and the heat dissipated by welding is removed, dismantle all the bolted connections from the suction tank to discharge pipe. Take out all demountable parts.
- Clean these parts and then paint body coat completely inside and outside.
- Mount the parts again in their intended places. However, this time start from the discharge line and move downward to the pump. In this instance, do not forget to check the flange gaskets. If needed, (for example deformation during welding) replace them.
- Concerning the connection of the pump flanges to piping, in case of misalignment of axis and flange holes, do not force the system to eliminate the misalignment. Forcing the system may cause difficult-to-correct problems.
- If there is an axial misalignment between the flanges of the pump and the pipe, due to the welding or any other reasons, cut the pipe from a suitable location in order to fix the problem. Connect the pipe (pump side) to the pump. After carrying out the necessary correction, connect the parts again by welding..
- Dismantle and clean the last welded part. Repaint again and mount on its place.
- After all these processes are accomplished, remove the rubber gasket from the suction and discharge openings. Open their holes and mount them again on their intended place.

6.2.3. Specification of Work after Installation of Piping and Piping System

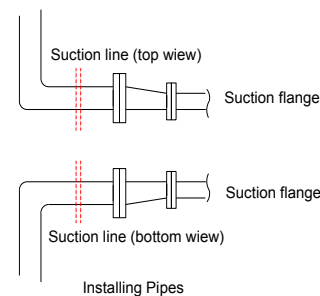

Figure 3: Piping System

An illustrative piping system is shown in Figure 6. Appropriate manometers shall be mounted on suction and discharge pipe lines.



Complete the auxiliary pipe connections in piping system if exist (cooling to bearing housing, and stuffing box (seal), relief pipe, oil pipe etc.)

6.3. Motor Connection

Motor shall be connected by an electrical technician according to the connection (switch) diagram. Local electricity policies regulations have to be applied.



- Electrical connections have to be made by authorized electricians.
- In dismantling the pump, make sure the electricity is cut off before taking the motor cover out.
- Use the appropriate electrical connection to the motor.

6.3.1. Motor Connection Diagram

Motors requiring high moments at start up shall not be connected star-delta

Frequency controlled motors, require high moment at start up and have to be cooled properly at low speeds. Provide the necessary cooling for the motors.

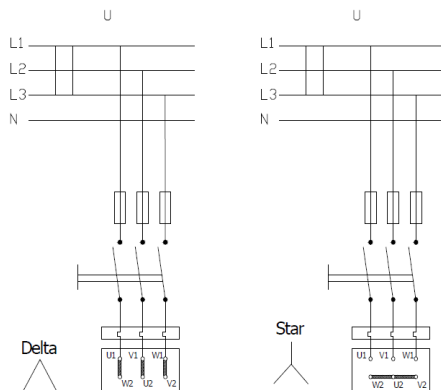

Figure 4: Electric Connection Diagram

Electrical circuit	Motor	
U (Volt)	230/400 V	400 V
3 x 230 V	Delta	
3 x 400 V	Star	Delta

6.3.2. Motor Protection

- Three phased-motor shall be connected to power supply.
- Wait the motor to cool down when thermic protected motor breaks in circuit due to the overheating. Make sure the motor does not start automatically until it cools completely
- In order to protect the motor from overcharging and short circuit use a thermic or thermic-magnetic relay. Adjust this relay to the nominal current of the motor.



Electrical equipments, terminals and the components of the control systems may carry electric current even though they are not operating. They may cause deadly and serious injuries or irreparable material damages.

7. COMMISSIONING, START UP AND OPERATING

7.1. Preparations Before Start Up

- Check pump seals
- Make sure that the pump and the suction pipe is completely filled with water before the starting. If the pump operates on a positive suction head, no problem will be encountered. Suction valve is opened and air drains are un-tightened.
- Pumps with foot valve are filled with water by opening the pump filling tap or, one takes advantage of the water accumulated in the discharge pipe and by using a small valve the check valve is bypassed and the pump is filled.
- In vacuum pump driven pumps, by operating the vacuum pump one achieves to fill the pump via increasing the water level in the suction pipe.



Do not start your pump dry (WITHOUT WATER).

7.2. Checking The Direction of Rotation



- The direction of rotation is indicated on the pump label with an arrow. Apart from special cases, it is clockwise direction when looking from the motor end. Observe if the pump is rotating in the expected sense by starting the motor for a very short instant. If it is turning in the opposite sense, interchange any of two motor leads.
- If the motor connection is delta, open the discharge valve slowly.
- If the motor connection is star-delta, set the time relay to maximum 5 seconds. Monitor the passage from star to delta by pressing the start button. As soon as you are assured that the connection is delta, open the discharge valve slowly. Continue opening the valve until you read the amperage on the electrical panel
- **One should always check the labels which show the direction of rotation and the direction of fluid flow. If you dismantle the coupling protection to monitor the direction of rotation, do not restart the engine before remounting the protection.**



As a result of getting in touch with rotating and stable parts each other temperature increase can occur. Never check the direction of rotation while the pump is dry.

7.3. Start up Procedure

- Check if the suction valve is open and the discharge valve is closed. Start the motor
- Wait until the motor reaches sufficient speed. (In Star-delta connections, wait until the engine passes to delta connection.)
- Keeping an eye on the amperage shown on the panel, open the discharge valve slowly.
- In the primary operation, if the discharge pipe is empty, do not open the valve completely. By keeping an eye on the amperage, open the valve with care regarding that it should not exceed the value indicated on pump's label.
- After opening the valve completely, check the pressure from the pump exit manometer and make sure that this value is the pump operating pressure value and is indicated on pump's label.
- If the value one reads is less than the pump label value when the valve is completely open, it means that the height is miscalculated. Increase the value by narrowing the valve and bring it to pump's label value.
- If the value one reads is greater than the pump label value when the valve is completely open, it means that the height is calculated less than what it should be in reality. The device is pumping less than what is requested. Check the installation and the calculations.
- **Minimum flow rate:** If the pump is working with zero flow rates (closed valve) from time to time during its operation, the water inside the pump may endanger the pump by getting warmed up. In such cases, a minimum flow valve must be connected to the pump exit.



Stop the motor if the pump gets too hot. Wait until it gets cold. Then start the system up again carefully.

7.4. Shut Down Procedure



During sudden start ups and stops, a pressure reducing valve must be placed at the exit section of high flow rate pumps whose discharge pipelines are long, in order to reduce water hammer effect. Water hammer may explode the pump.

In normal conditions (apart from sudden power shut down, etc), stop the pump as below:

- Close the discharge valve slowly
- Switch the power off, stop the motor. Notice that the rotor slows down.
- Do not start up the motor at least before 1 to 2 minutes.

- If the pump will be out of use for a long time, close the suction valve and auxiliary circuits. If the pump is outside and if there exists a danger of frost, remove all drain taps and empty all the water inside the pump. (5.2. Storage)



If the pump is outside and if there exists a danger of frost, remove all drain taps and empty all the water inside the pump.

8. MAINTENANCE



Maintenance operations must be done by authorized personnel with protective clothing only. The personnel must also beware of high temperatures and harmful and/or caustic liquids. Make sure that the personnel read carefully the manual.

- The instructions in Safety Precautions must be executed during maintenance and repair
- Continuous monitoring and maintenance will increase the engine's and pump's lives.

The instructions below should be applied.

8.1. The Checks During the Operation

- Pump must never be operated without water.
- Pump must not be operated for a long time with the discharge valve closed (zero capacity).
- Precautions must be taken against flare up when the component temperatures are over 60°C. "Hot Surface" warnings must be placed over necessary areas.
- All the auxiliary systems must be in use while the pump is operating.
- If the pump has mechanical sealing, there is no need for excessive maintenance. Water leakage from the mechanical sealing indicates the fact that the sealing is worn out and therefore needs to be replaced.
- If the system consists of a substitute pump, keep it ready by operating it once a week. Check also the auxiliary systems of the substitute pump.



Occurring explosive ambient inside of the pump must be prevent. The air of the pump and suction line must be drained before commissioning of the pump. The interior of the pump contacting with pumped liquid including gasket way and auxiliary systems must be filled with pumped liquid.

- Ensure that delivery pressure is enough.
- Exceeded the allowable using limits regarding pressure, temperature, transporting material and motor speed may cause explosion risk, hot and poison liquid may leak to external environment.

8.1.1. Component Check



To make possible the visual control, one must be able to reach the pump from any direction. Especially, to be able to dismount the internal units of the pump and the engine, sufficient free space must be created around them for maintenance and repair. Furthermore, one must make sure that the piping system can easily be dismounted.

8.1.2. Bearing and Lubrication

Rolling bearings are not used in INM/INL type pumps. Motor bearing is enough for countervailing all axial and radial forces. Motor bearings are provided with lifelong heat resistant grease.

8.1.3. Mechanical Seal

Mechanical seals are used in INM/INL type pumps. Mechanical Seals are absolutely leak-proof and needs less maintenance than soft packing.

Mechanical seal;

- 1.Provides leak proof operation in heavy operating conditions (in waste water pumps, chemical process and refinery pumps).
- 2.Easily mountable and needs less maintenance.
- 3.Does not cause wearing on the shaft
- 4.Sealing operation does not depend on the quality of shaft finishing.

8.1.4. Drive

Apply to the operating instructions of the motor manufacturer.

8.1.5. Auxiliary Components

Check regularly the fittings and the gaskets, replace the worn out pieces.

8.2. Service

Our Customer Service Department offers after-sale service. Manager should employ authorized and trained personnel for mounting/dismounting procedures. Before these procedures, one must make sure that pump interior is clean and empty.

This criterion is also valid for the pumps which are sent to our factory or to our service points.



Maintain the safety of the personnel and the environment in every field procedure.

8.3. Spare Parts

The spare parts of INM/INL type pumps are guaranteed for 10 years by **MAS DAF MAKINA SANAYI A.Ş.**

In your spare parts requests, please indicate the below listed values that are indicated on your pump's label.

- Pump type and size:**
- Motor power and speed:**
- Pump serial number:**
- Capacity and head:**

If you wish to keep spare parts in store, depending on the number of same type of pumps, for two operation years, the quantities which are listed in the table below are recommended.

Component Name	The Number of Equivalent Pumps in the Installation						
	1-2	3	4	5	6-7	8-9	10+
Shaft (Key included) (quantity)	1	1	2	2	2	3	%30
Impeller (quantity)	1	1	1	2	2	3	%30
Mechanical Seal	1	2	2	3	3	4	%50
Wear ring	1	1	1	2	2	3	%50
Rigid clamped coupling (INL)	1	2	2	3	3	4	%50

Table 1: Spare Part List

9. NOISE LEVEL AND VIBRATION

The reasons which increase the noise level are indicated below:

- Touch of coupling halves due to worn rubber sleeves (incorrectly aligned)
- Noise level increases due to the fact that the pump is not founded properly (Vibration)
- If the installation does not have compensator noise and vibration increases.
- Wearing in ball bearing also increases noise level.



Check if there is any noise increasing elements in your installation.

9.1. Expected Noise Values

Measurement conditions:

- The distance between the measure point and the pump : 1m
- Operation : Without Cavitation
- Motor : IEC Standard Motor
- Tolerance : ± 3 dB

Power of Motor PN [kW]	Sound Pressure Level (dB) *	
	Pump with Motor	
	1450 rpm	2900 rpm
< 0,55	63	64
0,75	63	67
1,1	65	67
1,5	66	70
2,2	68	71
3	70	74
4	71	75
5,5	72	83
7,5	73	83
11	74	84
15	75	85
18,5	76	85
22	77	85
30	80	93
37	80	93
45	80	93
55	82	95
75	83	95
90	85	95

Table 2: Sound Pressure Level

(*) Without protective sound hood, measured at a distance of 1 m directly above the driven pump, in a free space above a sound reflecting surface.

The above values are maximum values. The surface noise pressure level at dB(A) unit is shown as (L_{pA}). This complies with TS EN ISO 20361.

10. DISASSEMBLY, REPAIR AND REASSEMBLY



Before starting work on the pump set, make sure it is disconnected from the mains and can not be switched on accidentally.

Follow the safety precautions outlined in "Safety instructions".

10.1. Disassembly

- Close all valves in the suctions and discharge lines. Drain the water in the pump.
- Remove the safety guard.
- Because of the pump design, the impeller, shaft and other rotating parts being removable no need to disconnect the suction and delivery pipes. If there is not any operation on the casing, not need to remove the pipe connection.
- If to take out the complete pump is necessary, disconnect pump from the driver, suction and discharge pipes and detach the baseplate (If Any)
- Remove stud nuts (300) which connect the adapter to the casing and dismantle the rotor group with motor from the volute casing.
- Unscrew the end nuts (65) of the impeller and take out the impeller (20) and impeller key (210). Use rust remover solvent if necessary during dismantling.
- Take out the set screws on the pump shaft and take off the motor by unscrew the hex bolts (320)
- Pull out the rotating part of the mechanical seal (250) from the shaft.
- Take out the shaft.

10.2. Reassembly

- Reassembly proceeds in reverse sequence to disassembly as described in section 10.1. You may find the attached drawings useful.
- Coat the seats and screw connections with graphite, silicon or similar slippery substance before reassembly. If you can not find any of the above you may use oil instead. (Except the pumps for drinking water)
- Never use the old o-rings and make sure the o-rings are the same size as the old ones.
- Connect the pump shaft to the motor, fix the setscrews.
- Place the stationary part of mechanical seal to its place on the adaptor (12)
- Mount the adaptor to the motor flange.
- Slip the rotating part of the mechanical seal onto the pump shaft (61)
- Place the impeller key (210) into keyway, slide the impeller (20) onto the shaft (61) and screw the impeller nuts (65).
- Now reassembly of the rotor group is completed.
- Finally mount rotor assembly to the volute casing. (In the repair shop or on site)
- Make sure the gaskets and o-rings are evenly placed without sliding and not damaged or not squeezed at all.
- Place the pump on the baseplate, couple the motor. Connect suction and discharge pipes as well as auxiliary pipes. Take the unit into operation as it was indicated in section 7.

11. INFORMATION ABOUT FREQUENCY INVERTER

11.1. Installation Of The Frequency Inverter On The Motor

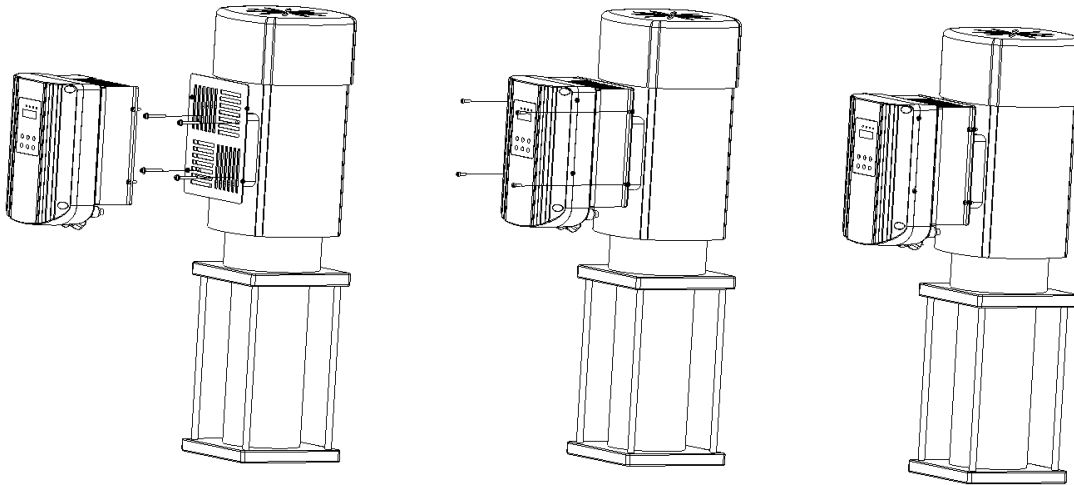

Fix the baseplate with 4 screws on the electrical box of motor. Install the frequency inverter on the baseplate and fix with 4 screws. Finish installation.

11.2. Making Of Electrical Connections

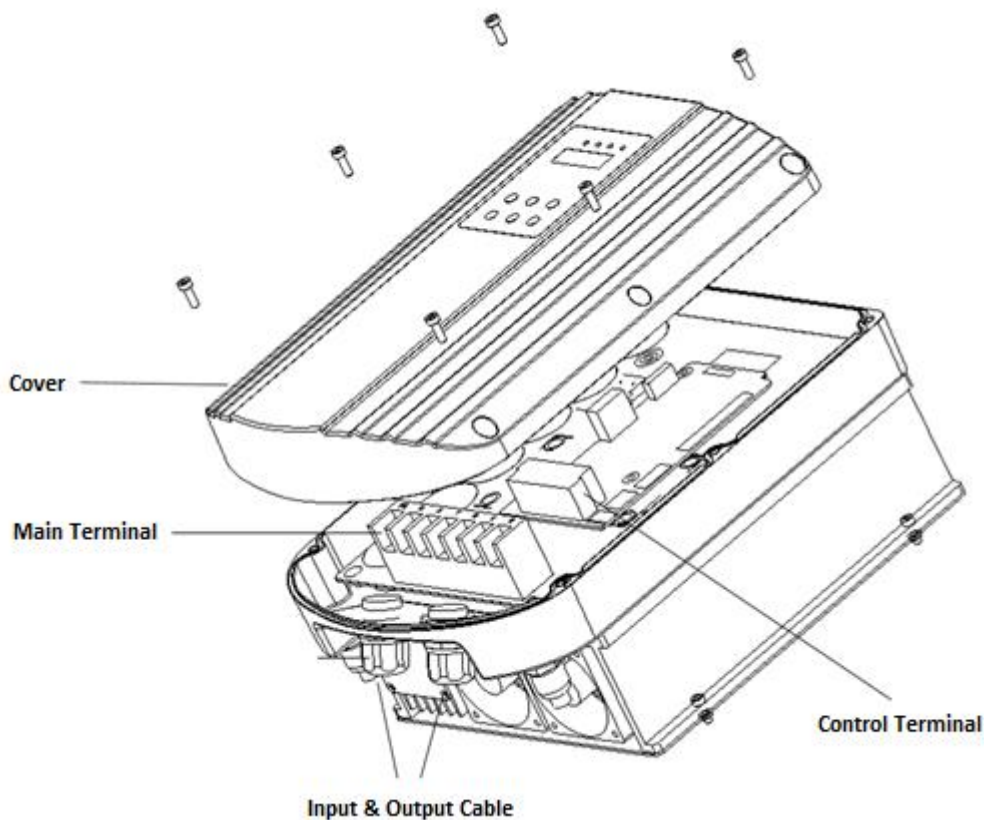

Dismantle the screws on operation panel, unplug the keyboard cable, and remove the cover. (Caution: do not break the keyboard cable). Each cable is connected to the terminals correctly through waterproof joint on the bottom. Connect the keyboard cable, install the cover and fix with screws.

11.3. Wiring Diagram

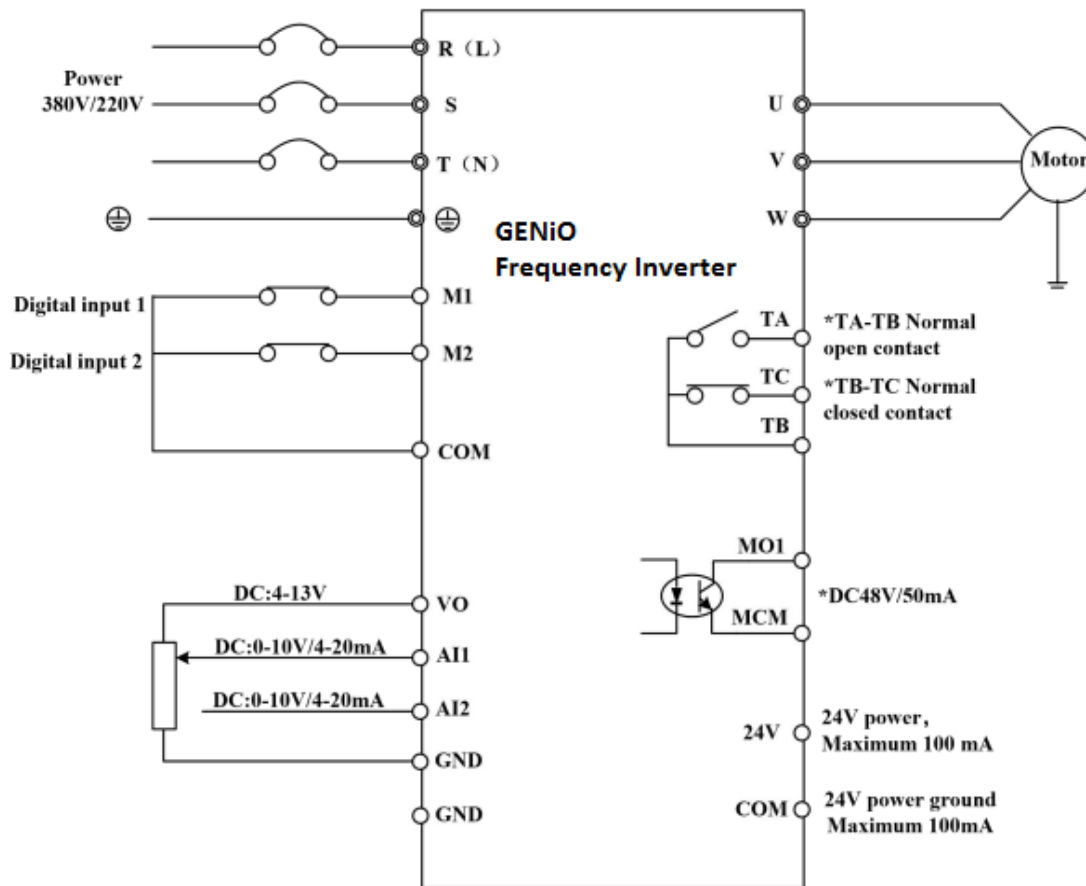

AI1 and AI2 are analog input terminals (pressure transmitter). AI1 will be connected as a priority in the system having single sensor.

11.4. Control Terminal

M1	M2	COM	COM	24V	S+	S-
----	----	-----	-----	-----	----	----

MO1	MCM	AI1	AI2	VO	GND	GND
-----	-----	-----	-----	----	-----	-----

TA	TB	TC
----	----	----

- M1, M2** : Multi-function digital input terminal
- AI1, AI2** : Analog Inputs
- VO** : Analog reference voltage
- GND** : Analog ground terminal
- TA/TB/TC** : Relay output
- 24V** : +24V power for external devices
- COM** : +24V power public terminal
- S+, S-** : Standard RS485 communication terminal
- MO1** : Multi-function analog output
- MCM** : Multi-function output

11.5. General Wiring Diagram In Multi-Pump System

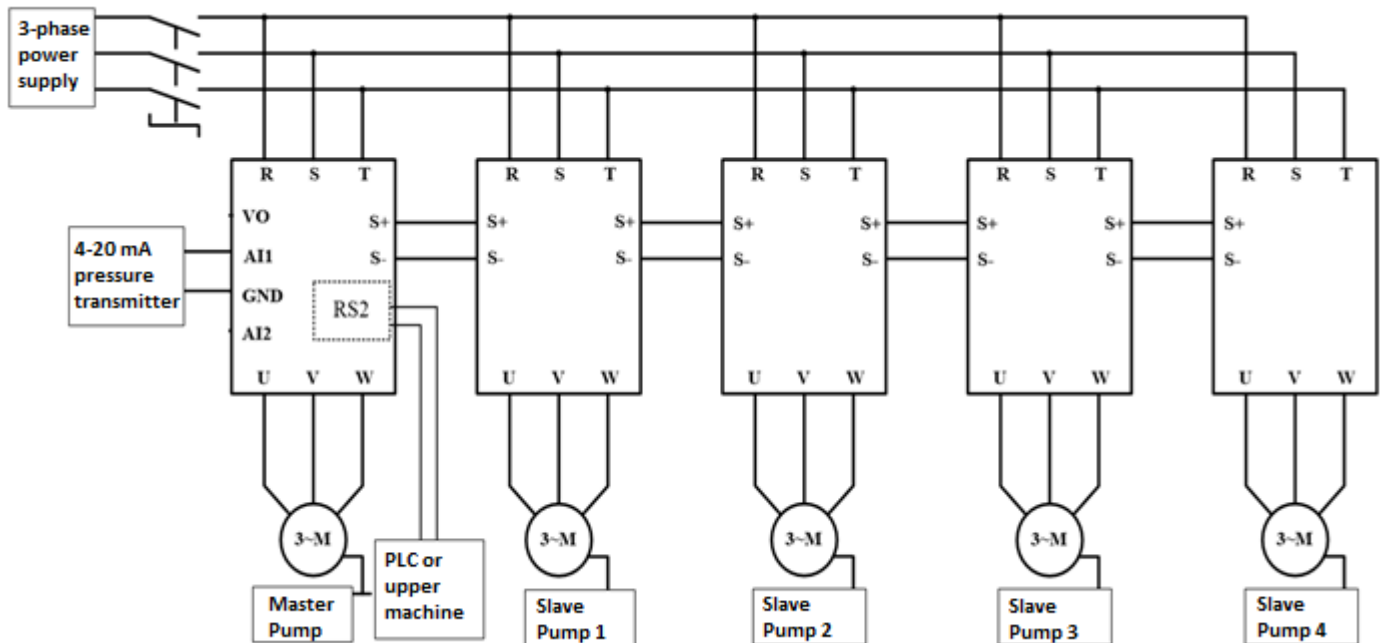

11.6. Use of Keypad



PRGM This key has two functions. It is reached to the pages where program parameters (F0, F1, F2...) are included by pressing longish on first page. Another function of it is to exit from the parameter page without saving any changes.

Pressure/ENT This key has two functions. One of them, by pressing this key longish on the first page, set pressure setting can be made by connecting set pressure setting parameter directly. Another function of it is to exit from the parameter page without losing any changes.

Shift Used to move the screen or cursor during the parameter setting. When it is on running mode, it allows to be changed values such as current pressure and current frequency.

▲ ▼ Used to change parameter values.

Run Allows the system to run.

Stop Allows the running system to be stopped.

11.7. Connections of Sensor

11.7.1. Transmissible pressure gauge: working voltage 4~13VDC, output 0~10VDC. Wiring method is shown as below.

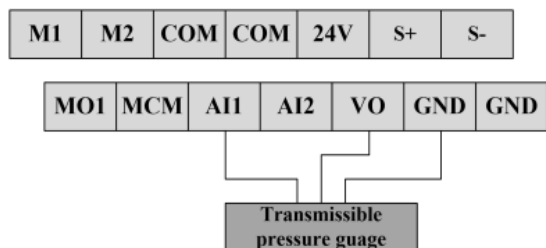

11.7.2. 24V pressure transmitter: working voltage range 10~30VDC, output 4~20mA.

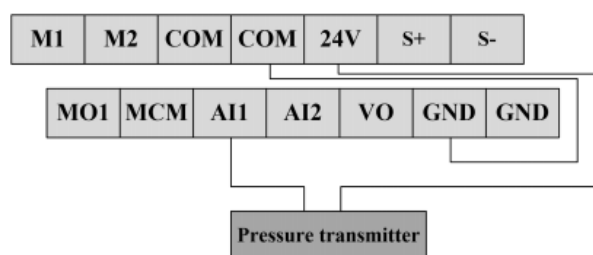

Sensor with two cables

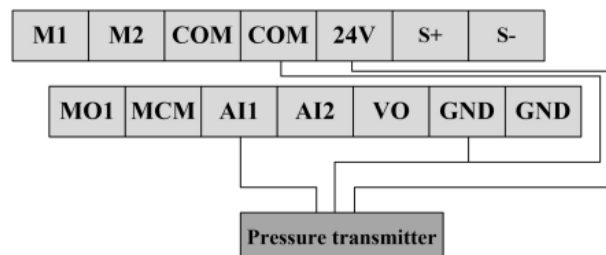

Sensor with three cables

Note: "Pressure transmitter with two cables will be connected from end 1 to 24V electric terminal and from end 2 to AI1 terminal.

Note: The blue cable will be connected to AI1 terminal and the brown cable will be connected to 24V electric terminal.

Note: (+) end of the temperature sensor connection will be connected to 24V electric terminal and its (-) end will be connected to AI1 terminal. In addition, if it is required to operate above the set temperature, the **F3.06** parameter will be set to **011**. If it is required to operate below the set temperature, the **F3.06** parameter will be set to **010**.

11.7.3. 10V pressure transmitter: working voltage range 10DC, output 4~20mA

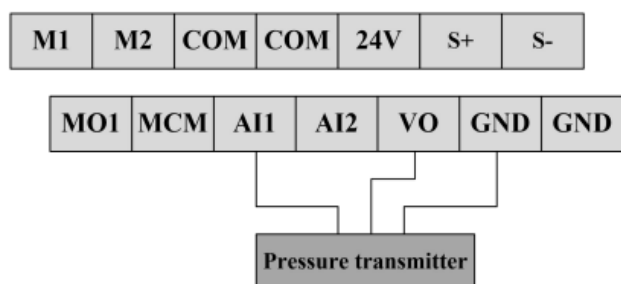

11.7.4. Closed contact floater connection is as follows:

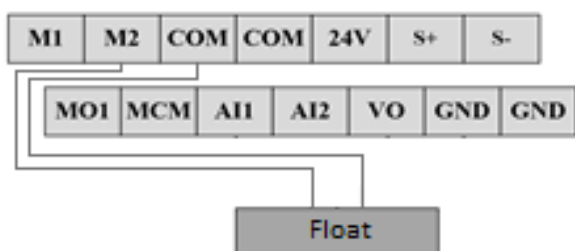

- There are 3 cables, the blue and black ones will be used for connection.

11.7.5. Open contact floater connection is as follows:

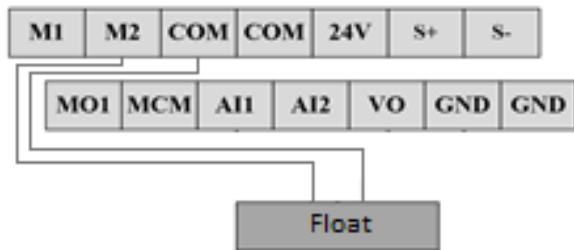

- There are 3 cables, the brown and black ones will be used for connection. At the same time, firstly, **F0.15** parameter will be set as **02** after that **F7.26** parameter will be set as **02** on the interface.

11.7.6. Open contact liquid level electrode connection is as follows:

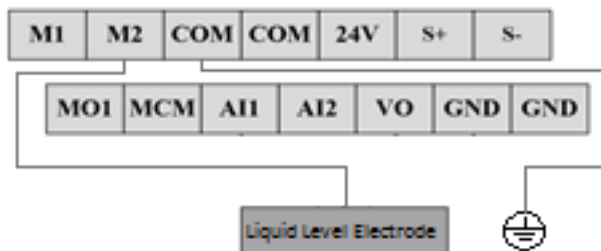

- During the liquid level electrode connection, while a cable is connected to M2, a bridge contact is made from COM to inverter ground connection. At the same time, firstly, **F0.15** parameter will be set as **02** after that **F7.26** parameter will be set as **02** on the interface.

11.7.7. Open contact PTC sensor connection is as follows:

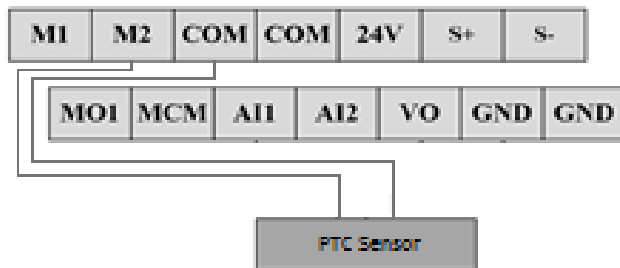

- PTC connection will be made as seen above. At the same time, firstly, **F0.15** parameter will be set as **02** after that **F7.26** parameter will be set as **02** on the interface.

11.7.8. Open contact PTC sensor and floater connection in series is as follows:

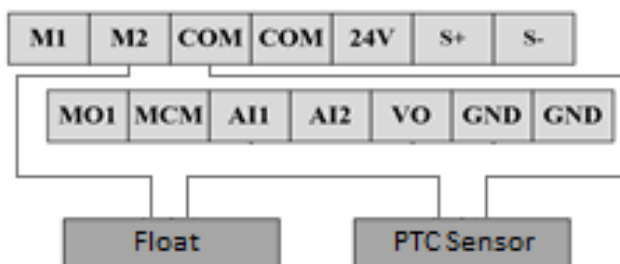

- There are 3 cables belonging to the floater, the brown and black ones will be used for connection. The brown one of the floater will be connected to M2 terminal and the black one will be connected to end of PTC cable. The other end of PTC cable will be connected to COM electric terminal. At the same time, firstly, **F0.15** parameter will be set as **02** after that **F7=26** parameter will be set as **02** on the interface.

11.7.9. Making Of Start-up Installation Setting

- Maximum working pressure of the sensor is set as 'bar' by F0.08 parameter. This value is set as 6 bar for pressure sensor conforming with 6 bar.
- Motor is introduced to the inverter by setting motor parameters on F5 setting menü.
- Direction of motor rotation is checked, if it is wrong, F0.02 value is changed from 1 to 0 or from 0 to 1.
- Macro Settings is made according to table below.
- Set pressure is set by F0.00 parameter.

System Type	Parameter
Solo Pump Setting	F0.20=1
2 Inverters, as Master	F0.20=2
3 Inverters, as Master	F0.20=3
4 Inverters, as Master	F0.20=4
5 Inverters, as Master	F0.20=5
6 Inverters, as Master	F0.20=6
One Inverter, one grid	F0.20=7
Emergency Mode	F0.20=9
Inverter Network, Slave No.1	F0.20=11
Inverter Network, Slave No.2	F0.20=12
Inverter Network, Slave No.3	F0.20=13
Inverter Network, Slave No.4	F0.20=14
Inverter Network, Slave No.5	F0.20=15

Example:

F0.20 is set as 3 on the inverter being Master in a system including 3 pumps and 3 frequency inverters.

The one of two remaining frequency inverters (1. Slave pump) is set as F0.20=11 and the second one (2. Slave pump) is set as F0.20=12 for macro setting of the system.

- Power and rotation speed of the motor must be introduced to frequency inverter.
Motor power is written as kW by F5.00 parameter.
Motor rotation speed is written as RPM by F5.02 parameter.
- Finally, set pressure must be set. Set pressure can be set in two ways. While it is in setting menu, by pressing Pressure/ENT key longish, set pressure value can be set as bar or by accessing parameters part, set pressure value is set as bar by F0.00 parameter.

12. POSSIBLE FAILURES, CAUSES, SOLUTIONS

Possible failures and solution strategies are listed in the table below. Please apply to the Customers' Service Department of our company when a generic solution is not found to your problem.



While the failures are repaired the pump must always be dry and un-pressurized.

POSSIBLE FAILURE	CAUSES	SOLUTIONS
The pump delivers insufficient capacity	<ul style="list-style-type: none"> Discharge head too high Very high counter pressure Pump and/or pipe cannot discharge air, cannot suck Occurrence of air pockets inside the pipe NPSH is too low 	<ul style="list-style-type: none"> Readjust the operating point See if there is any undesired material inside the pipe Vent completely the pump and the pipe Change the piping configuration Increase the liquid level
Motor overload	<ul style="list-style-type: none"> System pressure is lower than the requested pressure level Speed too high Liquid pumped of different specific gravity and viscosity than that for which pump is rated Engine works at two phases 	<ul style="list-style-type: none"> Adjust the operating pressure to the label value Decrease the speed Increase the engine power Replace the fuse and control the electrical connections
Pump head is too high	<ul style="list-style-type: none"> System pressure is higher than the requested pressure level 	<ul style="list-style-type: none"> Set the operating pressure to the label value.
Bearing temperatures are high	<ul style="list-style-type: none"> Too much, too little or improper lubrication Increase in axial forcing 	<ul style="list-style-type: none"> Change the oil, decrease or increase its quantity Clean the balance holes on the impeller disc
Excessive leakage from the stuffing box	<ul style="list-style-type: none"> Worn out gland 	<ul style="list-style-type: none"> Use brand new gland Change the stuffing bush
Noisy operation	<ul style="list-style-type: none"> Worn out motor or pump ball bearings Cavitation Operation in the far left or right of the performance curve 	<ul style="list-style-type: none"> Replace Close the delivery partially in order to reduce the capacity. Operate the pump at its label setting
Excessive increase in pump temperature	<ul style="list-style-type: none"> Pump and/or pipe can neither discharge, nor aspirate air Too low capacity 	<ul style="list-style-type: none"> Bleed completely the pump and the pipe Open more the valve
Vibration	<ul style="list-style-type: none"> Pump and/or pipe can neither discharge, nor aspirate air NPSH is too low Internal components of the pump are worn out System pressure is lower than the requested pressure level Too much, too little or improper lubrication Rotor unbalanced Improper bearings 	<ul style="list-style-type: none"> Bleed completely the pump and the pipe Increase the liquid level Replace the worn out components Adjust the operating pressure to the label value In case of continuous overload, decrease the impeller diameter Change the oil, decrease or increase its quantity Balance the impeller again Use new bearings

Table 3 - Possible Failures, Causes, Solutions

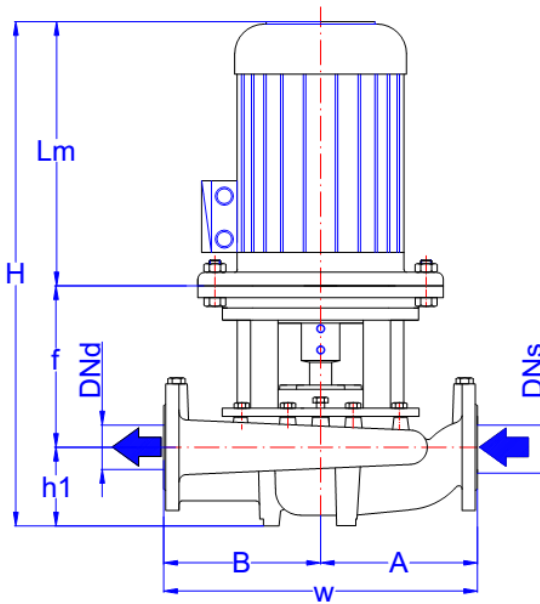
13. PUMP DIMENSIONS TABLE AND WEIGHTS

Figure 5: INM Pump Dimensions Figure

		MOTOR			FLANGES	GENERAL	PUMP					Mechanical Seal
		KW	IEC	Lm	DNs - DNd	H	h1	f	W	A	B	Nominal Impeller Diameter
				mm	mm	Mm						
40-125	4 poles	0.25	71	217	40	462	105	140	300	160	140	Ø 25
		0,37	71	217		462	105	140	300	160	140	Ø 25
	2 poles	0,75	80	238	40	483	105	140	300	160	140	Ø 25
		1,1	90S	258		503	105	140	300	160	140	Ø 25
		1,5	90L	283		528	105	140	300	160	140	Ø 25
		2.2	90L	283		528	105	140	300	160	140	Ø 25
3	100L	315	590	105	170	300	160	140	Ø 25			
40-160	4 poles	0.25	71	217	40	462	105	140	340	180	160	Ø 25
		0,37	71	217		462	105	140	340	180	160	Ø 25
		0,55	80	238		483	105	140	340	180	160	Ø 25
		0.75	80	238		483	105	140	340	180	160	Ø 25
	2 poles	2.2	90L	283	40	528	105	140	340	180	160	Ø 25
		3	100L	315		590	105	170	340	180	160	Ø 25
		4	112M	332		607	105	170	340	180	160	Ø 25
		5,5	132S	375		650	105	170	340	180	160	Ø 25
		7,5	132S	375		650	105	170	340	180	160	Ø 25
40-200	4 poles	0.37	71	217	40	447	95	135	380	190	190	Ø 20
		0.55	71	217		447	95	135	380	190	190	Ø 20
		0,75	80	238		493	95	160	380	190	190	Ø 20
		1.1	90S	258		513	95	160	380	190	190	Ø 20
	2 poles	3	100L	315	40	590	95	180	380	190	190	Ø 20
		4	112M	332		607	95	180	380	190	190	Ø 20
		5,5	132S	375		675	95	205	380	190	190	Ø 30
		7,5	132S	375		675	95	205	380	190	190	Ø 30
		11	160M	491		816	95	230	380	190	190	Ø 30

		MOTOR			FLANGES	GENERAL	PUMP					Mechanical Seal			
		KW	IEC	Lm	DNs - DNd	H	h1				f	W	A	B	Nominal Impeller Diameter
				mm	mm	mm	mm	mm	mm	mm	mm	mm	mm		
40-250	4 poles	0.75	80	238	40	507	100	169	440	215	225	Ø 20			
		1.1	90S	258		527	100	169	440	215	225	Ø 20			
		1.5	90L	283		552	100	169	440	215	225	Ø 20			
		2.2	100L	315		603.5	100	188.5	440	215	225	Ø 20			
		3	100L	315		603.5	100	188.5	440	215	225	Ø 20			
	2 poles	5.5	132S	375	40	688	100	213	440	215	225	Ø 30			
		7.5	132S	375		688	100	213	440	215	225	Ø 30			
		11	160M	491		829	100	238	440	215	225	Ø 30			
		15	160M	491		829	100	238	440	215	225	Ø 30			
50-125	4 poles	0.37	71	217	50	467	110	140	320	170	150	Ø 25			
		0.55	80	238		488	110	140	320	170	150	Ø 25			
		0,75	80	238		488	110	140	320	170	150	Ø 25			
	2 poles	1,5	90L	283	50	533	110	140	320	170	150	Ø 25			
		2.2	90L	283		533	110	140	320	170	150	Ø 25			
		3	100L	315		595	110	170	320	170	150	Ø 25			
		4	112M	332		612	110	170	320	170	150	Ø 25			
		5,5	132S	375		655	110	170	320	170	150	Ø 25			
	50-160	4 poles	0.37	71	217	50	482	125	140	360	190	170	Ø 25		
			0.55	80	238		503	125	140	360	190	170	Ø 25		
0,75			80	238	503		125	140	360	190	170	Ø 25			
1,1			90S	258	523		125	140	360	190	170	Ø 25			
1.5			90L	283	548		125	140	360	190	170	Ø 25			
2 poles		3	100L	315	50	610	125	170	360	190	170	Ø 25			
		4	112M	332		627	125	170	360	190	170	Ø 25			
		5,5	132S	375		670	125	170	360	190	170	Ø 25			
		7,5	132S	375		670	125	170	360	190	170	Ø 25			
		11	160M	491		816	125	200	360	190	170	Ø 25			
50-200	4 poles	0.55	71	217	50	472	110	145	400	200	200	Ø 20			
		0.75	80	238		508	110	160	400	200	200	Ø 20			
		1,1	90S	258		528	110	160	400	200	200	Ø 20			
		1.5	90L	283		553	110	160	400	200	200	Ø 20			
	2 poles	3	100L	315	50	605	110	180	400	200	200	Ø 20			
		4	112M	332		622	110	180	400	200	200	Ø 20			
		5.5	132S	375		690	110	205	400	200	200	Ø 30			
		7,5	132S	375		690	110	205	400	200	200	Ø 30			
		11	160M	491		831	110	230	400	200	200	Ø 30			
		15	160M	491		831	110	230	400	200	200	Ø 30			

		MOTOR			FLANGES	GENERAL	PUMP					Mechanical Seal	
		KW	IEC	Lm	DNs - DNd	H	h1	f	W	A	B	Nominal Impeller Diameter	
				mm	mm	mm	mm	mm	mm	mm	mm		mm
50-250	4 poles	0.75	80	238	50	513	115	160	440	215	225	Ø 20	
		1.1	90S	258		533	115	160	440	215	225	Ø 20	
		1.5	90L	283		558	115	160	440	215	225	Ø 20	
		2,2	100L	315		610	115	180	440	215	225	Ø 20	
		3	100L	315		610	115	180	440	215	225	Ø 20	
	2 poles	11	160M	491	50	836	115	230	440	215	225	Ø 30	
		15	160M	491		836	115	230	440	215	225	Ø 30	
		18.5	160L	491		836	115	230	440	215	225	Ø 30	
		22	180M	549		894	115	230	440	215	225	Ø 30	
30		200L	637	982		115	230	440	215	225	Ø 35		
65-125	4 poles	0.37	71	217	65	487	130	140	340	180	160	Ø 25	
		0.55	80	238		508	130	140	340	180	160	Ø 25	
		0.75	80	238		508	130	140	340	180	160	Ø 25	
	2 poles	2.2	90L	283	65	553	130	140	340	180	160	Ø 25	
		3	100L	315		615	130	170	340	180	160	Ø 25	
		4	112M	332		632	130	170	340	180	160	Ø 25	
		5,5	132S	375		675	130	170	340	180	160	Ø 25	
	65-160	4 poles	0.37	71	217	65	489	130	142	390	210	180	Ø 25
			0.55	80	238		510	130	142	390	210	180	Ø 25
0.75			80	238	510		130	142	390	210	180	Ø 25	
1,1			90S	258	530		130	142	390	210	180	Ø 25	
1,5			90L	283	555		130	142	390	210	180	Ø 25	
2 poles		3	100L	315	65	617	130	172	390	210	180	Ø 25	
		4	112M	332		634	130	172	390	210	180	Ø 25	
		5,5	132S	375		677	130	172	390	210	180	Ø 25	
		7,5	132S	375		677	130	172	390	210	180	Ø 25	
	11	160M	491	823		130	202	390	210	180	Ø 25		
	15	160M	491	823		130	202	390	210	180	Ø 25		
65-200	4 poles	0.55	71	217	65	477	115	145	460	230	230	Ø 20	
		0.75	80	238		513	115	160	460	230	230	Ø 20	
		1.1	90S	258		533	115	160	460	230	230	Ø 20	
		1.5	90L	283		558	115	160	460	230	230	Ø 20	
		2,2	100L	315		610	115	180	460	230	230	Ø 20	
	2 poles	4	112M	332	65	627	115	180	460	230	230	Ø 20	
		5.5	132S	375		695	115	205	460	230	230	Ø 30	
		7.5	132S	375		695	115	205	460	230	230	Ø 30	
		11	160M	491		836	115	230	460	230	230	Ø 30	
15		160M	491	836		115	230	460	230	230	Ø 30		
18,5		160L	491	836		115	230	460	230	230	Ø 30		

		MOTOR			FLANGES	GENERAL	PUMP					Mechanical Seal	
		KW	IEC	Lm	DNs - DNd	H	h1	f	W	A	B	Nominal Impeller Diameter	
				mm									mm
65-250	4 poles	1.5	90L	283	65	578	135	160	480	245	235	Ø 20	
		2.2	100L	315		630	135	180	480	245	235	Ø 20	
		3	100L	315		630	135	180	480	245	235	Ø 20	
		4	112M	332		647	135	180	480	245	235	Ø 20	
		5,5	132S	375		715	135	205	480	245	235	Ø 30	
	2 poles	15	160M	491	65	856	135	230	480	245	235	Ø 30	
		18.5	160L	491		856	135	230	480	245	235	Ø 30	
		22	180M	549		914	135	230	480	245	235	Ø 30	
		30	200L	637		1032	135	260	480	245	235	Ø 35	
		37	200L	637		1032	135	260	480	245	235	Ø 35	
		45	225M	680		1075	135	260	480	245	235	Ø 35	
80-160	4 poles	0.75	80	238	80	543	135	170	440	220	220	Ø 20	
		1,1	90S	258		563	135	170	440	220	220	Ø 20	
		1,5	90L	283		588	135	170	440	220	220	Ø 20	
		2,2	100L	315		640	135	190	440	220	220	Ø 20	
	2 poles	4	112M	332	80	657	135	190	440	220	220	Ø 20	
		5.5	132S	375		720	135	210	440	220	220	Ø 30	
		7,5	132S	375		720	135	210	440	220	220	Ø 30	
		11	160M	491		866	135	240	440	220	220	Ø 30	
		15	160M	491		866	135	240	440	220	220	Ø 30	
	80-200	4 poles	1.1	90S	258	80	558	140	160	500	250	250	Ø 20
			1.5	90L	283		583	140	160	500	250	250	Ø 20
2.2			100L	315	635		140	180	500	250	250	Ø 20	
3			100L	315	635		140	180	500	250	250	Ø 20	
4			112M	332	652		140	180	500	250	250	Ø 20	
2 poles		11	160M	491	80	861	140	230	500	250	250	Ø 30	
		15	160M	491		861	140	230	500	250	250	Ø 30	
		18.5	160L	491		861	140	230	500	250	250	Ø 30	
		22	180M	549		919	140	230	500	250	250	Ø 30	
		30	200L	637		1037	140	260	500	250	250	Ø 35	
		37	200L	637		1037	140	260	500	250	250	Ø 35	
80-250	4 poles	2.2	100L	315	80	650	145	190	550	270	280	Ø 20	
		3	100L	315		650	145	190	550	270	280	Ø 20	
		4	112M	332		667	145	190	550	270	280	Ø 20	
		5,5	132S	375		735	145	215	550	270	280	Ø 30	
		7,5	132M	421		781	145	215	550	270	280	Ø 30	
	2 poles	15	160M	491	80	876	145	240	550	270	280	Ø 30	
		18.5	160L	491		876	145	240	550	270	280	Ø 30	
		22	180M	549		934	145	240	550	270	280	Ø 30	
		30	200L	637		1052	145	270	550	270	280	Ø 35	
		37	200L	637		1052	145	270	550	270	280	Ø 35	
		45	225M	680		1095	145	270	550	270	280	Ø 35	

		MOTOR			FLANGES	GENERAL	PUMP					Mechanical Seal				
		KW	IEC	Lm	DNs - DNd	H	h1				f	W	A	B	Nominal Impeller Diameter	
				mm	mm	mm	mm	mm	mm	mm						mm
80-315	6 poles	1.1	90L	283	80	633	160				190	600	300	300	Ø 20	
		1.5	100L	315		665	160				190	600	300	300	Ø 20	
		2.2	112M	332		682	160				190	600	300	300	Ø 20	
		3	132S	375		750	160				215	600	300	300	Ø 20	
		4	132M	421		796	160				215	600	300	300	Ø 20	
	4 poles	4	112M	332	80	682	160				190	600	300	300	Ø 20	
		5.5	132S	375		750	160				215	600	300	300	Ø 30	
		7.5	132M	421		796	160				215	600	300	300	Ø 30	
		11	160M	491		891	160				240	600	300	300	Ø 30	
		15	160L	491		891	160				240	600	300	300	Ø 30	
100-160	4 poles	1,1	90S	258	100	583	155				170	500	250	250	Ø 20	
		1,5	90L	283		608	155				170	500	250	250	Ø 20	
		2,2	100L	315		660	155				190	500	250	250	Ø 20	
		3	100L	315		660	155				190	500	250	250	Ø 20	
	2 poles	11	160M	491	100	886	155				240	500	250	250	Ø 30	
		15	160M	491		886	155				240	500	250	250	Ø 30	
		18.5	160L	491		886	155				240	500	250	250	Ø 30	
		22	180M	549		944	155				240	500	250	250	Ø 30	
	100-200	4 poles	2.2	100L	315	100	685	180				190	550	275	275	Ø 20
			3	100L	315		685	180				190	550	275	275	Ø 20
4			112M	332	702		180				190	550	275	275	Ø 20	
5,5			132S	375	770		180				215	550	275	275	Ø 30	
7,5			132M	421	816		180				215	550	275	275	Ø 30	
2 poles		18.5	160L	491	100	911	180				240	550	275	275	Ø 30	
		22	180M	549		969	180				240	550	275	275	Ø 30	
		30	200L	637		1087	180				270	550	275	275	Ø 35	
		37	200L	637		1087	180				270	550	275	275	Ø 35	
		45	225M	680		1130	180				270	550	275	275	Ø 35	
100-250	6 poles	1.1	90L	283	100	648	190				175	600	320	280	Ø 20	
		1.5	100L	315		695	190				190	600	320	280	Ø 20	
		2.2	112M	332		712	190				190	600	320	280	Ø 20	
		3	132S	375		780	190				215	600	320	280	Ø 20	
	4 poles	3	100L	315	100	695	190				190	600	320	280	Ø 20	
		4	112M	332		712	190				190	600	320	280	Ø 20	
		5,5	132S	375		780	190				215	600	320	280	Ø 30	
		7,5	132M	421		826	190				215	600	320	280	Ø 30	
		11	160M	491		921	190				240	600	320	280	Ø 30	

		MOTOR			FLANGES	GENERAL	PUMP					Mechanical Seal				
		KW	IEC	Lm	DNs - DNd	H	h1				f	W	A	B	Nominal Impeller Diameter	
				mm	mm	mm	mm	mm	mm	mm	mm	mm	mm			
100-315	6 poles	2,2	112M	332		712	190				190	650	335	315	Ø 20	
		3	132S	375		755	190				190	650	335	315	Ø 20	
		4	132M	421		801	190				190	650	335	315	Ø 20	
		5,5	132M	421		801	190				190	650	335	315	Ø 20	
		7,5	132M	421		826	190				215	650	335	315	Ø 20	
	4 poles	7.5	132M	421	100	826	190				215	650	335	315	Ø 30	
		11	160M	491		921	190				240	650	335	315	Ø 30	
		15	160L	491		921	190				240	650	335	315	Ø 30	
		18,5	180M	549		979	190				240	650	335	315	Ø 30	
22		180L	549	979		190				240	650	335	315	Ø 30		
125-200	4 poles	3	100L	315		740	210				215	600	300	300	Ø 30	
		4	112M	332		757	210				215	600	300	300	Ø 30	
		5,5	132S	375		825	210				240	600	300	300	Ø 30	
		7,5	132M	421		871	210				240	600	300	300	Ø 30	
	2 poles	30	200L	637	125	1117	210				270	600	300	300	Ø 35	
		37	200L	637		1117	210				270	600	300	300	Ø 35	
		45	225M	680		1160	210				270	600	300	300	Ø 35	
	125-250	6 poles	1.1	90L	283	125	668	210				175	650	350	300	Ø 20
			1.5	100L	315		715	210				190	650	350	300	Ø 20
2.2			112M	332	732		210				190	650	350	300	Ø 20	
3			132S	375	800		210				215	650	350	300	Ø 20	
4			132M	421	846		210				215	650	350	300	Ø 20	
5.5			132M	421	846		210				215	650	350	300	Ø 30	
4 poles		4	112M	332	125	732	210				190	650	350	300	Ø 20	
		5.5	132S	375		800	210				215	650	350	300	Ø 30	
		7.5	132M	421		846	210				215	650	350	300	Ø 30	
	11	160M	491	941		210				240	650	350	300	Ø 30		
	15	160L	491	941		210				240	650	350	300	Ø 30		
	18,5	180M	549	999		210				240	650	350	300	Ø 30		
125-315	6 poles	3	132S	375	125	830	210				245	700	370	330	Ø 20	
		4	132M	421		876	210				245	700	370	330	Ø 20	
		5.5	132M	421		876	210				245	700	370	330	Ø 30	
		7.5	160M	491		971	210				270	700	370	330	Ø 30	
		11	160L	491		971	210				270	700	370	330	Ø 30	
	4 poles	11	160M	491	125	971	210				270	700	370	330	Ø 30	
		15	160L	491		971	210				270	700	370	330	Ø 30	
		18,5	180M	549		1029	210				270	700	370	330	Ø 30	
		22	180L	549		1029	210				270	700	370	330	Ø 30	
30		200L	637	1147		210				300	700	370	330	Ø 35		
37		225S	655	1215		210				350	700	370	330	Ø 35		

		MOTOR			FLANGES	GENERAL	PUMP					Mechanical Seal			
		KW	IEC	Lm	DNs - DNd	H	h1				f	W	A	B	Nominal Impeller Diameter
				mm	mm	mm	mm	mm	mm	mm					
150-200	6 poles	1.1	90L	283	150	688	190				215	670	315	355	Ø 20
		1.5	100L	315		735	190				230	670	315	355	Ø 20
		2.2	112M	332		752	190				230	670	315	355	Ø 20
		3	132S	375		820	190				255	670	315	355	Ø 20
		4	132M	421		866	190				255	670	315	355	Ø 20
	4 poles	4	112M	332	150	752	190				230	670	315	355	Ø 20
		5.5	132S	375		820	190				255	670	315	355	Ø 30
		7.5	132M	421		866	190				255	670	315	355	Ø 30
		11	160M	491		961	190				280	670	315	355	Ø 30
		15	160L	491		961	190				280	670	315	355	Ø 30
150-250	6 poles	3	132S	375	150	830	180				275	670	315	355	Ø 20
		4	132M	421		876	180				275	670	315	355	Ø 20
		5.5	132M	421		876	180				275	670	315	355	Ø 30
		7.5	160M	491		971	180				300	670	315	355	Ø 30
	4 poles	11	160M	491	150	971	180				300	670	315	355	Ø 30
		15	160L	491		971	180				300	670	315	355	Ø 30
		18,5	180M	549		1029	180				300	670	315	355	Ø 30
		22	180L	549		1029	180				300	670	315	355	Ø 30
		30	200L	637		1147	180				330	670	315	355	Ø 30
		30	200L	637		1147	180				330	670	315	355	Ø 30
150-315	6 poles	4	132M	421	150	911	210				280	770	390	380	Ø 20
		5.5	132M	421		911	210				280	770	390	380	Ø 30
		7.5	160M	491		1006	210				305	770	390	380	Ø 30
		11	160L	491		1006	210				305	770	390	380	Ø 30
	4 poles	15	160L	491	150	1006	210				305	770	390	380	Ø 30
		18,5	180M	549		1064	210				305	770	390	380	Ø 30
		22	180L	549		1064	210				305	770	390	380	Ø 30
		30	200L	637		1182	210				335	770	390	380	Ø 35
		37	225S	655		1250	210				385	770	390	380	Ø 35
		37	225S	655		1250	210				385	770	390	380	Ø 35
150-360	6 poles	5.5	132M	421	150	1021	190				410	800	400	400	Ø 50
		7.5	160M	491		1091	190				410	800	400	400	Ø 50
		11	160L	491		1091	190				410	800	400	400	Ø 50
		15	180L	549		1149	190				410	800	400	400	Ø 50
	4 poles	18,5	180M	549	150	1149	190				410	800	400	400	Ø 50
		22	180L	549		1149	190				410	800	400	400	Ø 50
		30	200L	637		1237	190				410	800	400	400	Ø 50
		37	225S	655		1255	190				410	800	400	400	Ø 50
		45	225M	680		1280	190				410	800	400	400	Ø 50
		55	250M	755		1355	190				410	800	400	400	Ø 50
		55	250M	755		1355	190				410	800	400	400	Ø 50

		MOTOR			FLANGES	GENERAL	PUMP					Mechanical Seal
		KW	IEC	Lm	DNS - DNd	H	h1	f	W	A	B	Nominal Impeller Diameter
				mm								
200-315	6 poles	7.5	160M	491	200	1136	200	445	850	400	450	Ø 50
		11	160L	491		1136	200	445	850	400	450	Ø 50
		15	180L	549		1194	200	445	850	400	450	Ø 50
		18.5	200L	637		1282	200	445	850	400	450	Ø 50
		22	200L	637		1282	200	445	850	400	450	Ø 50
	4 poles	30	200L	637	200	1282	200	445	850	400	450	Ø 50
		37	225S	655		1300	200	445	850	400	450	Ø 50
		45	225M	680		1325	200	445	850	400	450	Ø 50
		55	250M	755		1400	200	445	850	400	450	Ø 50
75		280S	767	1412		200	445	850	400	450	Ø 50	

Table 4 - INM Pump Dimensions Table and Weights
14. TIGHTENING TORQUES

THREAD DIAMETER	TIGHTENING TORQUEMAX (Nm)	
	Property Classes	
	8.8	10.9
M4	3.0	4.4
M5	5.9	8.7
M6	10	15
M8	25	36
M10	49	72
M12	85	125
M14	135	200
M16	210	310
M18	300	430
M20	425	610
M22	580	820
M24	730	1050
M27	1100	1550
M30	1450	2100
M33	1970	2770
M36	2530	3560

Table 5 - Tightening Torques Table

15. FORCES AND MOMENTS AT THE PUMP FLANGES

All of the applied load if not reached the maximum allowable value, to provide that the following additional conditions, one of these loads may exceed the normal limit:

- Any component of a force or a moment, must be limited 1.4 times of the maximum allowable value,
- The actual force and moments acting on each flange, should provide the following formula:

$$\left(\frac{\sum |F|_{\text{actual}}}{\sum |F|_{\text{maximum allowable}}} \right)^2 + \left(\frac{\sum |M|_{\text{actual}}}{\sum |M|_{\text{maximum allowable}}} \right)^2 \leq 2$$

In here, $\sum |F|$ and $\sum |M|$ are arithmetic sum of the loads for each flange at the pump level, without regard of the algebraic signs of the actual and maximum allowable values.

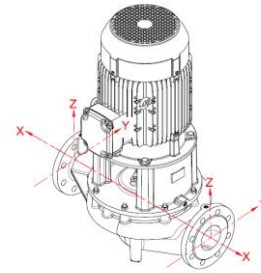

PUMP TYPE	FORCES AND MOMENTS						
	DN FLANGE	SUCTION AND DISCHARGE FLANGE			SUCTION AND DISCHARGE FLANGE		
	mm	N			Nm		
		F _y	F _z	F _x	M _y	M _z	M _x
INM-H 40-125	40	595,3	476,2	523,82	428,58	500,01	619,06
INM-H 40-160							
INM 40-200							
INM 40-250							
INM-H 50-125	50	785,7	642,9	714,3	476,2	547,63	666,68
INM-H 50-160							
INM 50-200							
INM 50-250							
INM-H 65-125	65	1000	809,5	880,97	523,82	571,44	714,3
INM-H 65-160							
INM 65-200							
INM 65-250							
INM 80-160	80	1191	976,2	1071,45	547,63	619,06	761,92
INM 80-200							
INM 80-250							
INM 80-315							
INM 100-160	100	1595	1286	1428,6	595,25	690,49	833,35
INM 100-200							
INM 100-250							
INM 100-315							
INM 125-200	125	1881	1524	1690,51	714,3	904,78	1000
INM 125-250							
INM 125-315							
INM 150-200	150	2381	1929	2142,9	833,35	976,21	1190,5
INM 150-250							
INM 150-315							
INL 150-360							
INL 200-315	200	3040,2	2440,5	2713,8	1065	1223,2	1612,4

Table 6 - Forces and Moments at The Pump Flanges

Forces at the pump flanges were calculated according to TS EN ISO 5199 standard. The calculations are valid for the materials of cast iron and bronze. Forces and moments at the flanges that made of stainless material will be approximately twice as moments in the table.

16. SAMPLE PLUMBING

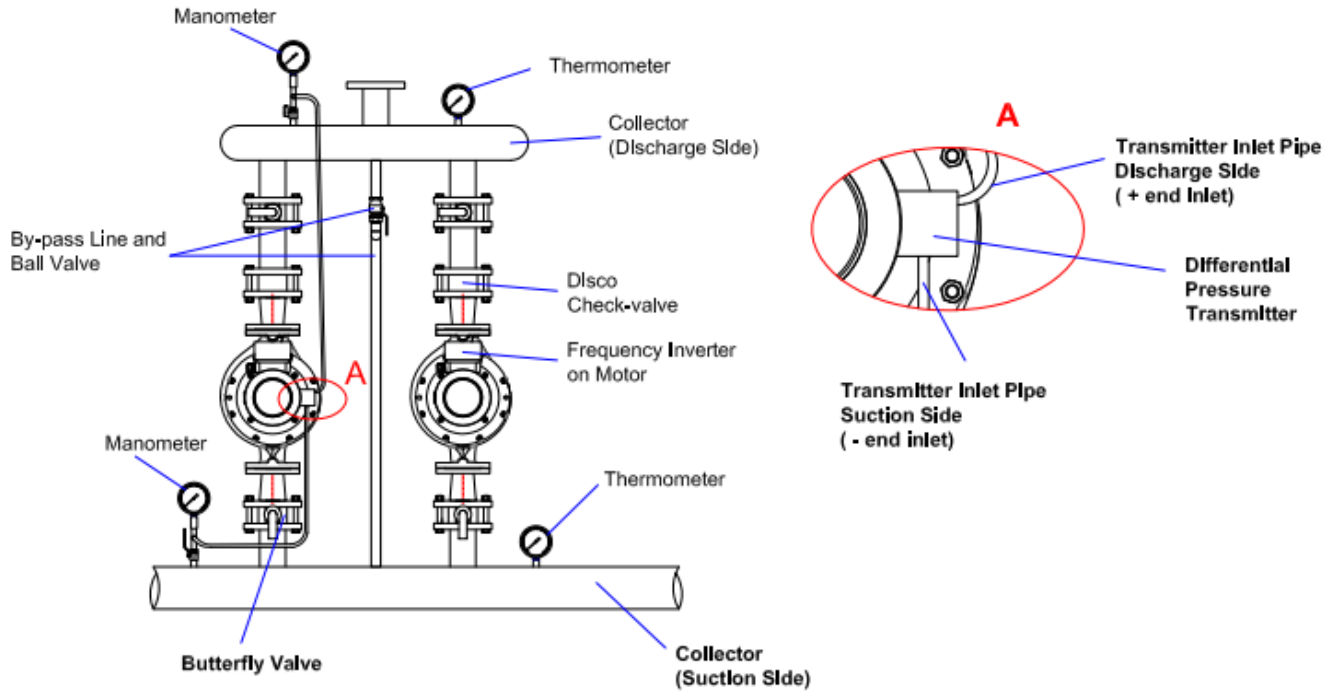
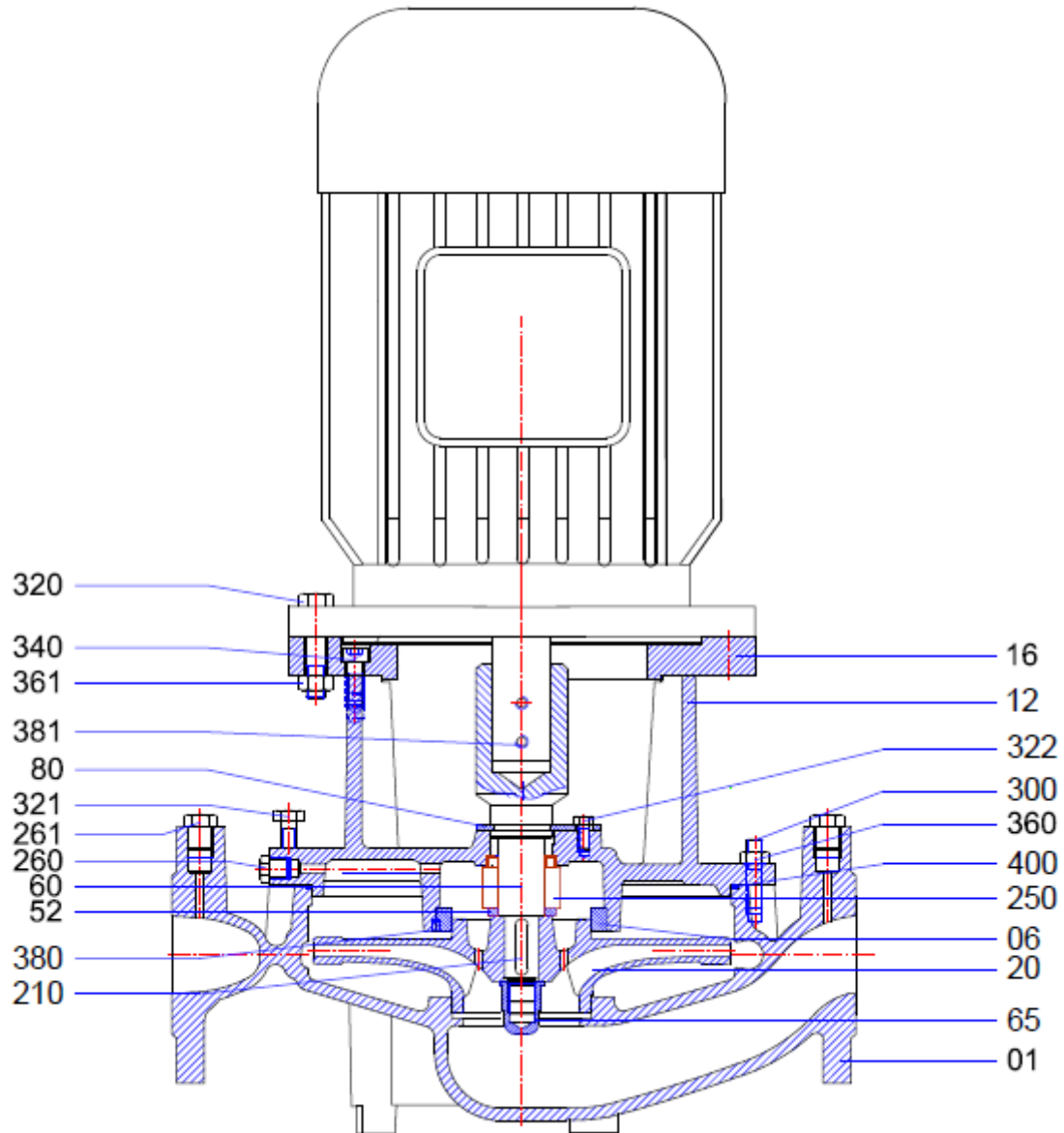
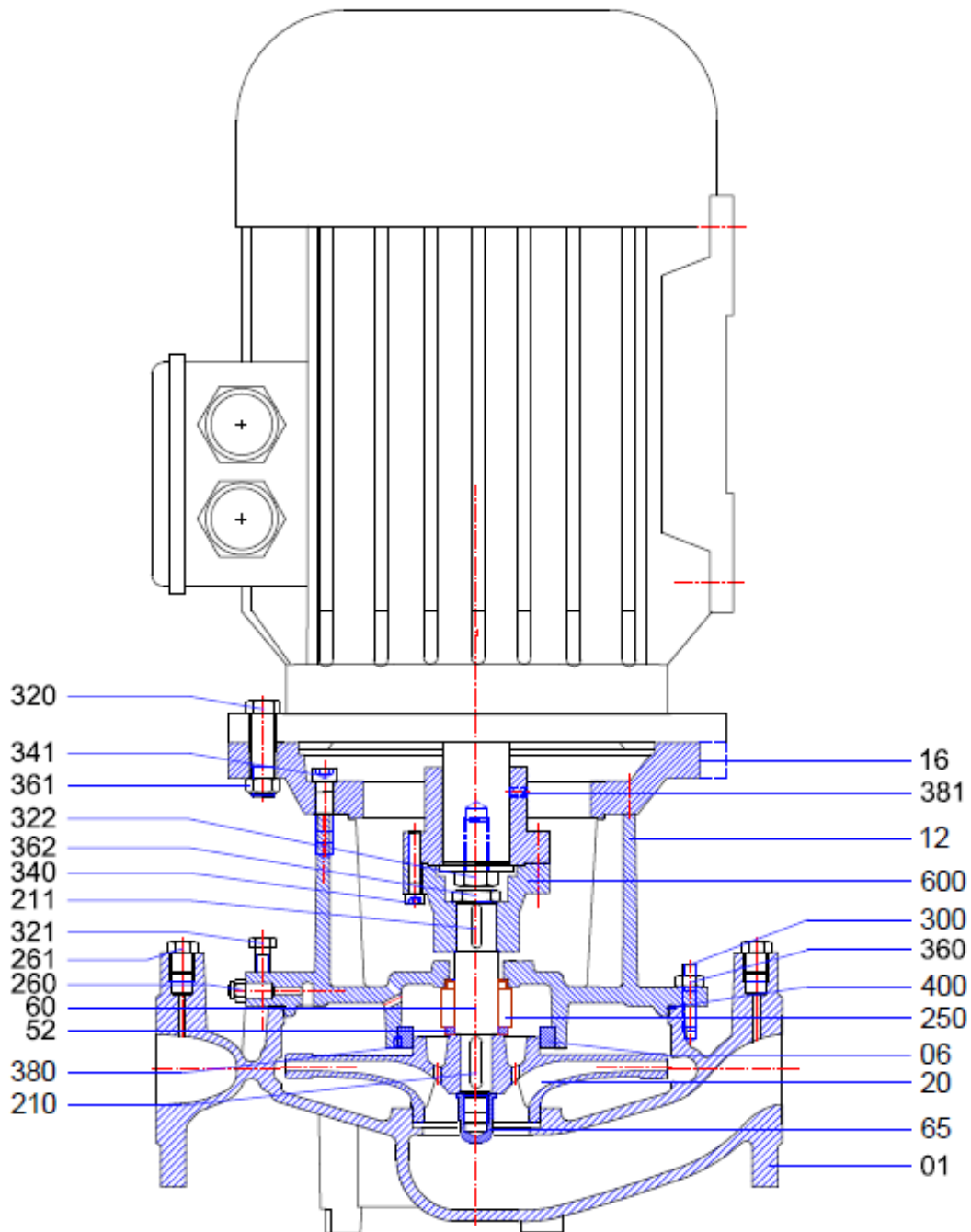

Figure 6: Sample Plumbing

17. INM SECTIONAL DRAWING AND PARTS LIST (WITHOUT COUPLING)

Figure 7: INM Sectional Drawing (without coupling)

Part No	Part Name	Part No	Part Name
01	Pump Casing	261	Pipe Plug, Pressure Gauge
06	Wearing Ring	300	Stud, Pump Casing
12	Adapter	320	Hex Bolt
16	Motor Flange	321	Hex Bolt
20	Impeller	322	Hex Bolt
52	Mechanical Seal Ring	340	Imbus Bolt
60	Pump Shaft	360	Nut
65	Impeller Nut	361	Nut
80	Shackle	380	Set-Screw
210	Key, Impeller	381	Set-Screw
250	Mechanical Seal	400	O-Ring
260	Pipe Plug, Adapter	500	Motor

Table 7: INM Sectional Part List (without coupling)

INM SECTIONAL DRAWING AND PARTS LIST (WITH COUPLING)

Figure 8: INM Sectional Drawing (with coupling)

Part No	Part Name	Part No	Part Name
01	Volute casing	300	Casing stud
06	Wear Ring	320	Hex Bolt
12	Adapter	321	Hex Bolt
16	Motor Flange	322	Hex Bolt
20	Impeller	340	Imbus Bolt
52	Mechanical Seal Ring	341	Imbus Bolt
60	Shaft	360	Nut
65	Impeller nut	361	Nut
210	Key, Impeller	362	Nut
211	Kama, coupling	380	Setscrew
250	Mechanical Seal	381	Setscrew
260	Solid plug	400	O-Ring
261	Drain plug	600	Rigid coupling

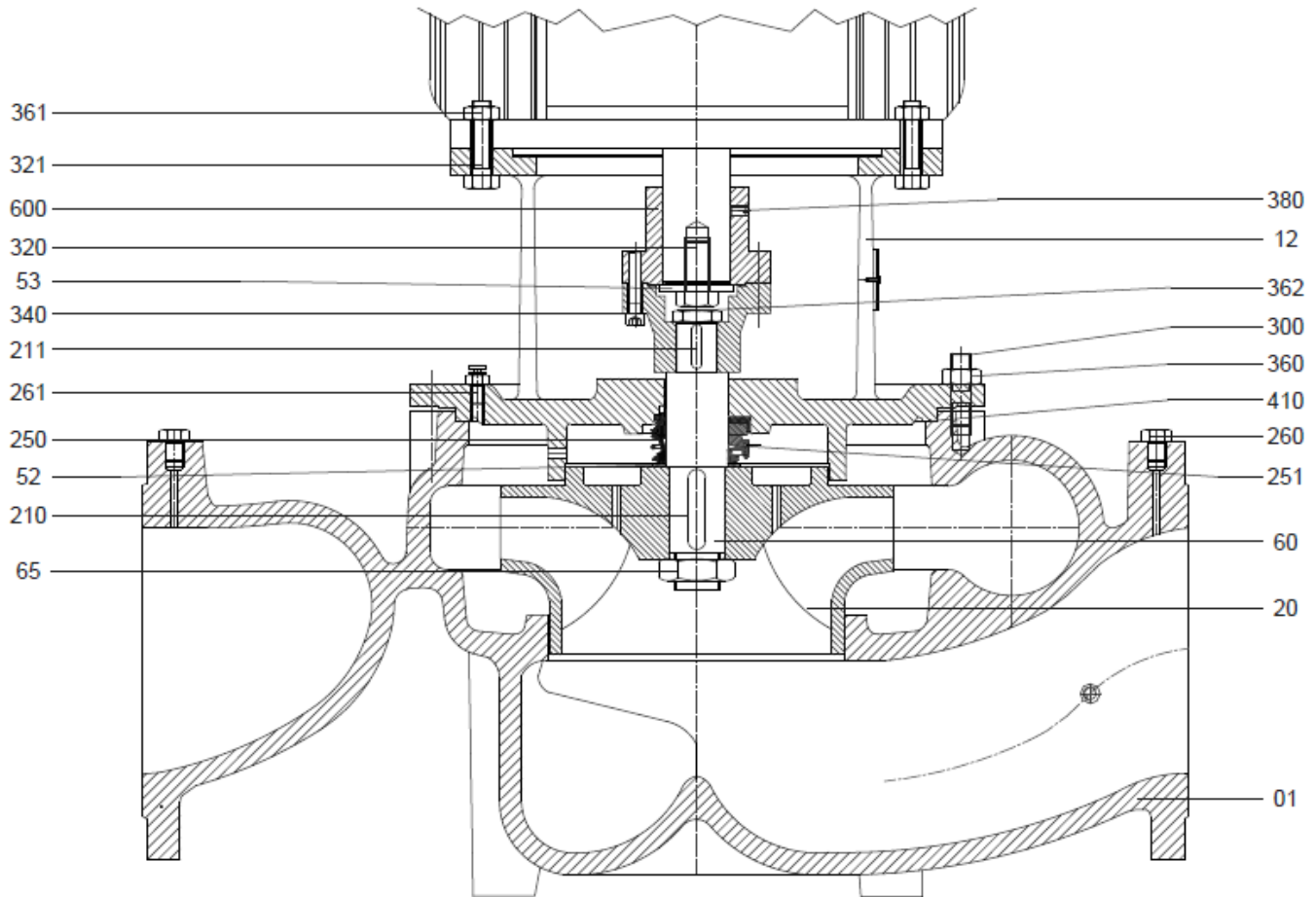
Table 8: INM Sectional Part List (with coupling)

INL SECTIONAL DRAWING AND PARTS LIST

Figure 9: INL Sectional Drawing

Part No	Part Name	Part No	Part Name
01	Volute casing	261	Slud (Adapter)
12	Adapter	300	Casing stud
20	Impeller	320	Hex Bolt (Coupling)
52	Mechanical Seal Ring	321	Hex Bolt (Adapter)
53	Coupling Front Bush	340	Imbus Bolt (Coupling)
60	Shaft	360	Nut (Casing)
65	Impeller nut	361	Nut (Adapter)
210	Key, Impeller	362	Nut (Coupling)
211	Key, Coupling	380	Setscrew
250	Mechanical Seal	410	Cylinder Head Gasket
251	Mechanical Seal	600	Rigid Coupling
260	Slud (casing)		

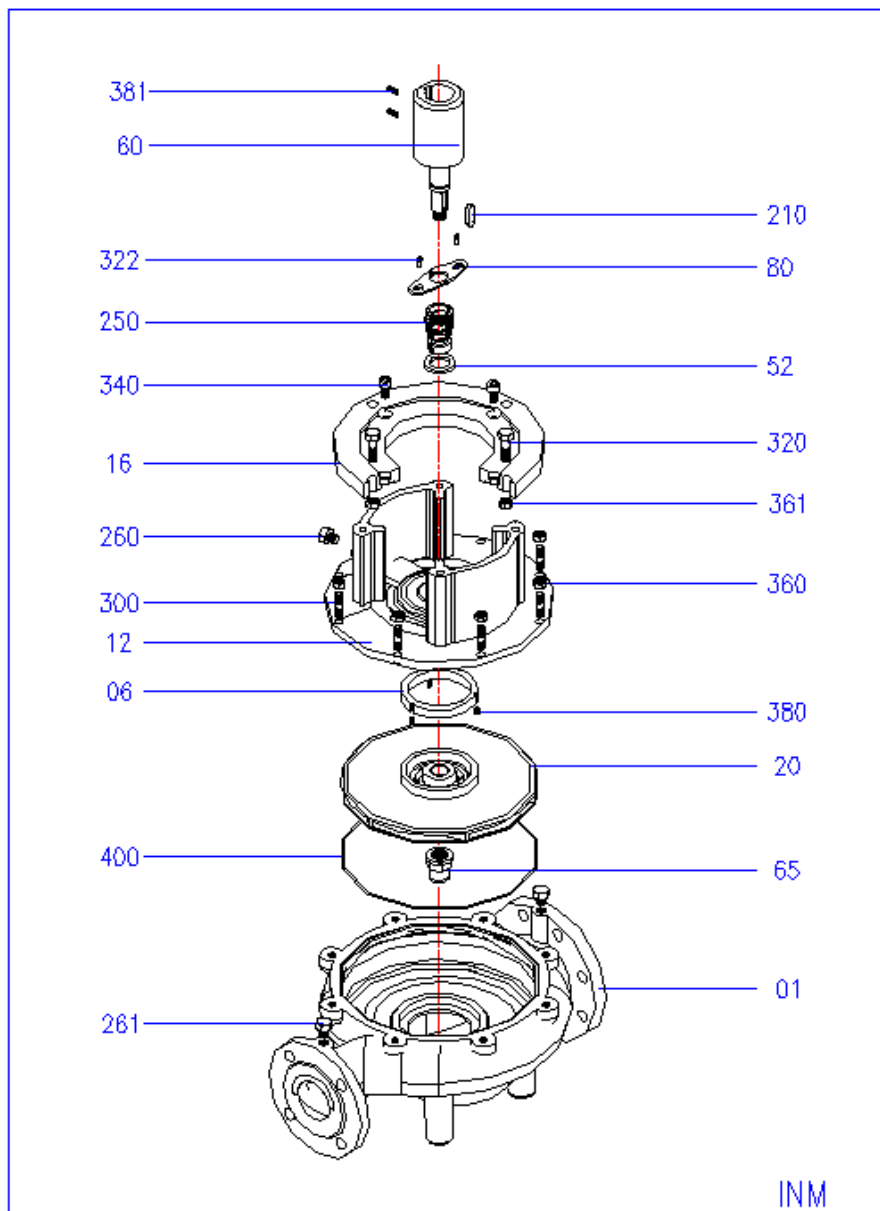
Table 9: INL Sectional Part List

18. INM DRAWING FOR DISMANTLING (WITHOUT COUPLING)

Figure 10: INM Drawing For Dismantling (without coupling)

Part No	Part Name	Part No	Part Name
01	Volute Casing	260	Pipe Plug, Adapter
06	Wear Ring	261	Pipe Plug, Pressure Gauge
12	Adapter	300	Stud, Volute Casing
16	Motor Flange	320	Hex Bolt
20	Impeller	322	Hex Bolt
52	Mechanical Seal Ring	340	İmbus Bolt
60	Pump Shaft	360	Nut
65	Impeller Nut	361	Nut
80	Shackle	380	Setscrew
210	Key, Impeller	381	Setscrew
250	Mechanical Seal	400	O-Ring

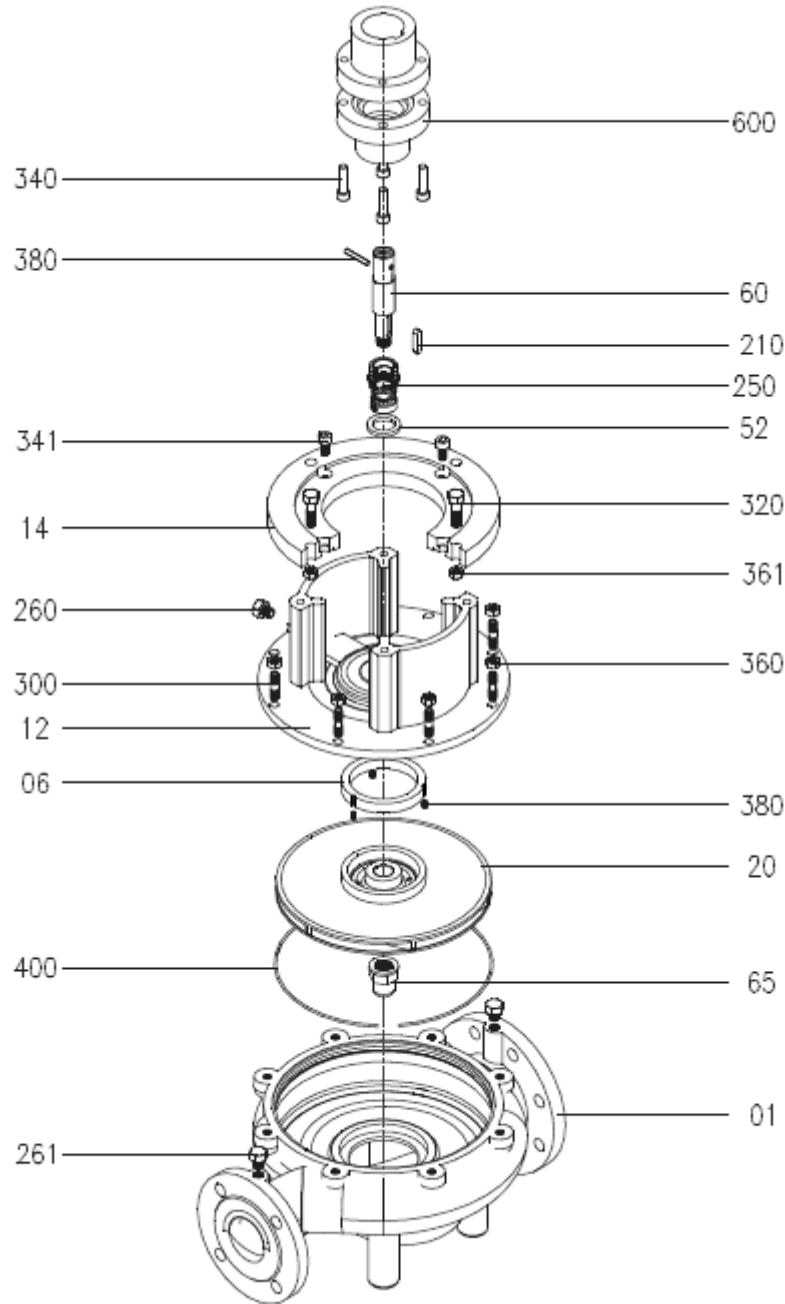
Table 10: INM Drawing For Dismantling Part List (without coupling)

INM DRAWING FOR DISMANTLING (WITH COUPLING)

Figure 11: INM Drawing For Dismantling (with coupling)

Part No	Part Name	Part No	Part Name
01	Volute Casing	300	Stud, Volute Casing
06	Wear Ring	320	Hex Bolt
12	Adapter	340	Imbus Bolt
14	Motor Flange	341	Imbus Bolt
20	Impeller	360	Nut
52	Mechanical Seal Ring	361	Nut
60	Pump Shaft	380	Setscrew
65	Impeller Nut	381	Setscrew
210	Key, Impeller	390	Grooved Pin
250	Mechanical Seal	400	O-Ring
260	Pipe Plug, Adapter	600	Rigid Coupling
261	Pipe Plug, Pressure Gauge		

Table 11: INM Drawing For Dismantling Part List (with coupling)

19. INM / INL SERIES MEI VALUE TABLE

Pump Type	Speed (rpm)	MEI
INM-H 40-125	1450	0.4
INM-H 40-160	1450	0.7
INM 40-200	1450	0.7
INM 40-250	1450	0.5
INM-H 50-125	1450	0.4
INM-H 50-160	1450	0.4
INM 50-200	1450	0.6
INM 50-250	1450	0.6
INM-H 65-125	1450	0.4
INM-H 65-160	1450	0.4
INM 65-200	1450	0.5
INM 65-250	1450	0.7
INM 80-160	1450	0.6
INM 80-200	1450	0.7
INM 80-250	1450	0.7
INM 80-315	1450	0.7
INM 100-160	1450	0.5
INM 100-200	1450	0.5
INM 100-250	1450	0.6
INM 100-315	1450	0.7
INM 125-200	1450	0.5
INM 125-250	1450	0.5
INM 125-315	1450	0.5
INM 150-200	1450	0.5
INM 150-250	1450	0.5
INM 150-315	1450	0.6
INL 150-360	1450	0.4
INL 200-315	1450	0.4

Table 12: INM / INL MEI Table (1450 rpm)

Pump Type	Speed (rpm)	MEI
INM-H 40-125	2900	0.5
INM-H 40-160	2900	0.7
INM 40-200	2900	0.5
INM 40-250	2900	0.7
INM-H 50-125	2900	0.4
INM-H 50-160	2900	0.4
INM 50-200	2900	0.4
INM 50-250	2900	0.4
INM-H 65-125	2900	0.5
INM-H 65-160	2900	0.4
INM 65-200	2900	0.4
INM 65-250	2900	0.7
INM 80-160	2900	0.5
INM 80-200	2900	0.5
INM 80-250	2900	0.5
INM 100-160	2900	0.4
INM 100-200	2900	0.5
INM 125-200	2900	0.4

Table 13: INM / INL MEI Table (2900 rpm)

20. FIGURE LIST

		Page No
Figure 1	Pump Label	2
Figure 2	Transport of Pump Group	3
Figure 3	Piping System	4
Figure 4	Electric Connection Diagram	5
Figure 5	INM Pump Dimensions Figure	15
Figure 6	Sample Plumbing	24
Figure 7	INM Sectional Drawing (without coupling)	25
Figure 8	INM Sectional Drawing (with coupling)	26
Figure 9	INL Sectional Drawing	27
Figure 10	INM Drawing For Dismantling (without coupling)	28
Figure 11	INM Drawing For Dismantling (with coupling)	29

21. TABLE LIST

		Page No
Table 1	Spare Part List	6
Table 2	Sound Pressure Level	7
Table 3	Possible Failures, Causes, Solutions	14
Table 4	INM Pump Dimensions Table And Weight	15
Table 5	Tightening Torques Table	22
Table 6	Forces and Moments at The Pump Flanges	23
Table 7	INM Sectional Part List (without coupling)	25
Table 8	INM Sectional Part List (with coupling)	26
Table 9	INL Sectional Part List	27
Table 10	INM Drawing For Dismantling Part List (without coupling)	28
Table 11	INM Drawing For Dismantling Part List (with coupling)	29
Table 12	INM / INL MEI Table (1450 rpm)	30
Table 13	INM / INL MEI Table (2900 rpm)	30



Mas Grup

Head Office / Center Service:

Aydınlı Mah. Birlik OSB. 1.No'lu Cadde No:17 Tuzla - İSTANBUL / TÜRKİYE
Tel: +90 (216) 456 47 00 pbx Fax: +90 (216) 455 14 24

Ankara Regional Directorate:

Aşağı Öveçler Mah. 1329 Sok. No:6/9 Öveçler ANKARA / TURKEY
Tel: +90 (312) 472 81 60-67 Fax: +90 (312) 472 82 51

Factory:

1. Organize Sanayi Bölgesi Parsel 249/5 Beyköy - DÜZCE / TÜRKİYE
Tel: +90 (380) 553 73 88 Fax: +90 (380) 553 71 29