

Horizontal High Pressure Multistage Centrifugal Pumps

KMU SERIES

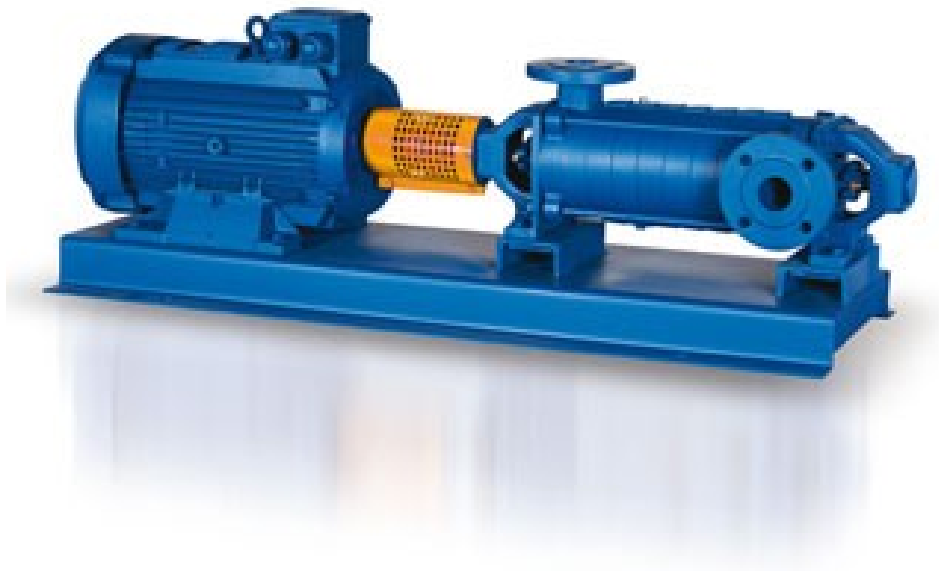

**KMU Series
ATEX Version**



OPERATING MANUAL





EC DECLARATION OF CONFORMITY

AT UYGUNLUK BEYANI

Manufacturer / İmalatçı : MAS DAF MAKİNA SANAYİ A.Ş.

Address / Adres : Aydınlı Mah. Birlik OSB. 1.No' lu Cadde No:17 Tuzla - İSTANBUL / TÜRKİYE

Name and address of the person authorized to compile the technical file Vahdettin YIRTMAÇ
Aydınlı Mah. Birlik OSB. 1.No' lu Cadde No:17
Teknik Dosyayı Derleyen Yetkili Kişi ve Adresi Tuzla - İSTANBUL / TÜRKİYE

The undersigned Company certifies under its sole responsibility that the item of equipment specified below satisfies the requirements of the mainly Machinery Directive 2006/42/EC which is apply to it.

The item of equipment identified below has been subject to internal manufacturing checks with monitoring of the final assessment by MAS DAF MAKİNA SANAYİ A.Ş.

Aşağıda tanımlanmış olan ürünler için Makine Emniyeti yönetmeliği 2006 / 42 / AT' nin uygulanabilen gerekliliklerinin yerine getirildiğini ve sorumluluğun alınmış olduğunu beyan ederiz.

Aşağıda tanımlanan ürünler iç üretim kontrollerine bağlı olarak MAS DAF MAKİNA SANAYİ A.Ş. tarafından kontrol edilmiştir.

Equipment / Ürün : Horizontal High Pressure Multistage Centrifugal Pumps
Yüksek Basıncılı Çok Kademeli Yatay Milli Santrifüj Pompalar

Seri / Model-Tip : KMU Series - KMU Serisi

For pumps supplied with drivers/ Elektrikli Pompa Üniteleri Related Directives / Yönetmelikler
2006/42/EC Machinery Directive / 2006/42/AT Makine Emniyeti Yönetmeliği
2014/35/EU Low Voltage Directive / 2014/35/AB Alçak Gerilim Yönetmeliği
2014/30/EU Electromagnetic Compatibility Directive / 2014/30/AB Elektromanyetik Uyumluluk Yönetmeliği
EUP 2009/ 125 /EC Electric Used Products Directive/ Elektrik Kullanan Ekipmanlar Direktifi (EUP)
94/9/EC Equipment For Explosive Atmospheres / Patlayıcı Ortamlardaki Ekipman Yönetmeliği

Regulations applied acc. to harmonize standards / Uygulanan Uyumlaştırılmış Standartlar
TS EN ISO 12100:2010, TS EN 809+A1, TS EN 60204-1:2011.

We hereby declare that this equipment is intended to be incorporated into, or assembled with other machinery to constitute relevant machinery to comply with essential health and safety requirements of Directive The machinery covered by this declaration must not be put into service until the relevant machinery into which it is to be incorporated has been declared in conformity with provisions of the directive.

Ekipman, uygun bir makina oluşturmak amacıyla diğer ekipmanlar ile birleştirilirken ya da monte edilirken gerekli sağlık ve güvenlik yönetmeliklerine uyulması gerekmektedir.

Bu bildiri kapsamında yönetmelikte belirtilen bütün hükümler yerine getirilmeden makinenin devreye alınmaması gerekmektedir.

Place and date of issue / Yer ve Tarih : İstanbul, 02.06.2014

Name and position of authorized person : Vahdettin YIRTMAÇ
Yetkili Kişinin Adı ve Görevi General Manager / Genel Müdür

Signature of authorized person :
Yetkili Kişinin İmzası

TABLE OF CONTENTS

	Page No
Introduction	1
1. Important Safety Precautions	1
2. General	1
3. Safe Operating Conditions	2
4. Technical Information	3
5. Transport and Storage	4
6. Assembly / Installation	4
6.1. Installation	4
6.2. Type of Connection	4
6.3. Foundation	4
6.4. Coupling Alignment	5
6.5. Piping	6
6.6. Motor Connection	7
7. Commissioning ,Start up and Operating	7
7.1. Preparations Before Start-up	7
7.2. Checking the Direction of Rotation	7
7.3. Start-up Procedure	7
7.4. Shut Down Procedure	8
8. Maintenance	8
8.1. The Checks During the Operation	8
8.2. Maintenance Instructions in ATEX Version Pumps	9
8.3. Service	9
8.4. Spare Parts	9
9. Noise Level and Vibration	9
10. Disassembly, Repair and Reassembly	10
11. Possible Failures, Causes, Solutions	11
12. Pump Dimensions Table and Weights	12
13. Tightening Torques	12
14. Forces and Moments At The Pump Flanges	12
15. Sample Pipework	13
16. KMU Sectional Drawing and Spare Part List	14
17. Alternative Applications	15
18. Different Installation Applications	15
19. KMU Drawing for Dismantling	16

INTRODUCTION



- This manual contains instructions for the installation, operation and maintenance of the KMU type non-self priming, horizontal multi-stage centrifugal pumps of **MAS DAF MAKİNA SAN. A.Ş.**
- Please read carefully this manual and apply all the instructions to operate pumps without problems. Pumps shall be used for their intended duties. In this manual, there are information on operating conditions, installation, starting-up, settings and main controls of pumps.
- These operating and maintenance instructions contain **MAS DAF MAKİNA SAN. A.Ş.**'s suggestions. The special operating and maintenance information of the plumbing that a pump is fitted to is not considered in these instructions. This information must be given by the plumbing constructors only.
- **Please refer to instructions of plumbing constructors.**
- Please pay attention to the warnings in this manual and ensure that it is read before the installation-start up process. **MAS DAF MAKİNA SAN. A.Ş.** is not responsible for the accidents resulting from negligence.
- If you cannot find an answer to your questions in this manual, it is suggested that you contact **MAS DAF MAKİNA SAN. A.Ş.** Please inform us about the rated value and especially the serial number of the pump when you get in contact for help
- The safety instructions in this manual cover the current national accident protection regulations. Beside all of these, an operation, work and safety measure imposed by the customer has to be applied.

The Signs Used in This Operation Manuel



Read the instructions carefully in this operating manual and keep it for your future reference.



Warning sign against the electrical risks



Sign for the operator's safety.



Sign for protecting against explosion.

1. IMPORTANT SAFETY PRECAUTIONS

In order to minimize the accidents during the mounting and putting into service of the pump, the following rules have to be applied:

1. Do not work without taking safety measures relevant to equipment. Cable, mask and safety band must be used when necessary.
2. Be sure there is adequate amount of oxygen and there is no toxic gaseous around
3. Before using welding or any electrical equipment make sure that there is no risk of explosion.
4. Check the cleanliness of the area to take care of your help. (Dust, smoke, etc.)
5. Do keep in mind that there is a risk of having accidents related to electricity
6. Do not lift the pump before you check the transport equipment.
7. Be sure you have a by-pass line
8. Use helmet, eye glasses and protective shoes for your safety
9. Place a protective barrier around the pump within the necessary safety area
10. Dust, liquids and gaseous that may cause overheating, short circuit, corrosion and fire must be kept away from the pump unit.
11. By checking the noise level of the pump unit, necessary measures to avoid noisy operation of the pump that can have harmful effects on the personnel and environment.
12. Be careful about the direction of transport and storage.
13. Cover appropriately the moving parts to avoid possible injury of the personnel. Mount the coupling guard and belting before starting-up the pump
14. All the electrical and electronic applications must be performed by authorized person conforming EN60204-1 and /or domestic instructions.
15. Protect the electrical equipment and motor against overloading
16. If flammable and explosive liquids are pumped, ground connection of electricity should be carried out properly
17. Do not expose the pump unit to sudden temperature variations
18. All personnel who work with the waste water system need to be vaccinated in case of contagious diseases.
19. If the pump contains hazardous liquids, one must use protective helmet against the risk of splatter. One also must accumulate the liquid in a proper container against any risk of leakage.

All Other Health and Safety Rules, Laws and Regulations Must Be Applied

2. GENERAL

2.1. Definition of Pump and Usage Areas

KMU series pumps are non self-priming, horizontal multi stage centrifugal pumps. They are used in

- Water pump stations
- Water pressurization for tall buildings
- Water purification facilities
- Washings systems
- Fire extinguishing
- Boiler feeding and Condense water pumping
- Boiler, bottle, barrel washing
- Health and cleaning facilities
- Industrial facilities
- Pumping of fresh water in ships

They shall be used to pressurize liquids which are clean or mildly impure, non-abrasive and not containing large solid particles or fiber.

CAUTION

Please contact MAS DAF MAKİNA SAN. A.Ş. for liquids that have different chemical and physical specifications.

CAUTION

For applications with liquid temperature exceeding 105 °C, especially for boiler feeding pumps, the pump shall be kept away from the boiler as much as possible and ventilation of environment has to be assured.

Technical specifications of KMU type pumps

Suction Flange	DN 25...DN 50
Discharge Flange	DN 25...DN 50
Operating Pressure	25 bar
Maximum liquid temperature	105 °C
Number of stages	3-18
Flow rate (Q)	1-16 m ³ /hour
Head	40-250 m
Speed of Rotation	2900 rpm

Pump Label

MAS DAF
 Typ:
 S/N: Year:
 Power(kW): Hm(mSS):
 Speed(rpm): Q(m³/h):
 Dia(mm): Eff(η_p):%
 MAS DAF MAKINA SANAYI A.Ş.
 1.038 2485 Beykoz/DUZCE
 Tel: +90 216 456 47 00 www.masgrup.com
 CE MADE IN TURKEY

ATEX Version Pump Label

MAS DAF ATEX Code II 2Gc II B T3
 Type:
 S/N: Year:
 Power(kW): Hm(mSS):
 Speed(rpm): Q(m³/h):
 Diameter(mm): Eff(η_p):%
 ATEX Certificate No :
 MAS DAF MAKINA SANAYI A.Ş.
 1.038 2485 Beykoz/DUZCE
 Tel: +90 216 456 47 00 www.masgrup.com
 CE MADE IN TURKEY

2.2. Performance Information

Actual performance of the pump can be obtained from the order page and/or from the test report. This information is given on the pump label. The performance curves given in the catalog are valid for water whose density and viscosity are $\rho=1 \text{ kg/dm}^3$ and $\nu=1\text{cst.}$ respectively. For those liquids whose densities and viscosities are different from those of water, please consult with **MAS DAF MAKINA SAN. A.Ş.** since the performance curves vary with density and viscosity.



Do not operate the pump with a motor that has a different power except for the given catalog and label values. The pump is not to be operated at off-design point given in the order and supplied from the firm. It is necessary to ensure that the instructions are obeyed for the safe running of the pump.

2.3. Warranty Conditions

The entire products in our selling program are warranted by **MAS DAF MAKINA SANAYI A.Ş.**

The warranty conditions will only be valid when all the instructions about installation and start-up operations of the pump unit are taken into account.

2.4. Test

All Pumps are dispatched for sale when all the performance and pressure tests are completed. Proper assurance of material and fault-free operation of pumps whose performance tests are made is under the warranty of **MAS DAF MAKINA SAN. A.Ş.**

2.5. Pressure Limit



Pressure at the discharge flange must not exceed 25 bar. A special order is necessary for applications with higher pressures.

2.6. ATEX Description

The undersigned Company certifies under its sole responsibility that the item of equipment specified below satisfies the requirements of the ATEX Directive 94/9/EC which is apply to it.

Please read cautiously all instructions emphasized with ATEX sign in this manual.

ATEX Codification

ATEX -95



II 2G /D c Tx (85 °C – 200 °C)

Equipment Groups (Annex I of Directive 94/9/EC)							
Group I (mines, mine gas and dust)		Group II (other explosive atmospheres gas/dust)					
Category M 1	Category M 2	Category 1		Category 2		Category 3	
		G (gas) (Zone 0)	D (dust) (Zone 20)	G (gas) (Zone 1)	D (dust) (Zone 21)	G (gas) (Zone 2)	D (dust) (Zone 22)
For equipment providing a very high level of protection when endangered by an explosive atmosphere	For equipment providing a high level of protection when likely to be endangered by an explosive atmosphere	For equipment providing a very high level of protection when used in areas where an explosive atmosphere is very likely to occur	For equipment providing a high level of protection when used in areas where an explosive atmosphere is likely to occur	For equipment providing a normal level of protection when used in areas where an explosive atmosphere is less likely to occur			

TEMPERATURE CLASS		
Temperature class required by the area classification	Ignition temperature of gas or vapor	Allowable temperature classes of equipment
T1	> 450 °C	T1 - T6
T2	> 300 °C	T2 - T6
T3	> 200 °C	T3 - T6
T4	> 135 °C	T4 - T6
T5	> 100 °C	T5 - T6
T6	> 85 °C	T6

Code	Description
II	The Usage in other non-mining explosive atmospheres
2	2. Category: High level of protection
G	For potentially explosive environments due to gases or vapors
T	Temperature class
X	ATEX Marking of the motor manufacturer

3. SAFE OPERATING CONDITIONS

This manual contains main safety instructions for the installation, operation and maintenance. It must be read by the personnel who are responsible for installation and operation. This manual should always be kept near the installation location. It is important to comply with safety precautions stated in page 1 along with the general safety instructions as well as preventive measures repeated in other sections of this manual.

3.1. Training of Personnel

Installation, operation and maintenance personnel must have necessary knowledge in order to accomplish the given job. The responsibility, adequacies and controlling duties of such personnel must be determined by the costumer. It has to be certain that these personnel comprehend totally the content of the operating manual. If the personnel do not have enough knowledge, required training must be given by the costumer. If training support is needed by the costumer, it will be provided by the manufacturer/seller.

CAUTION

Untrained personnel and unwillingness to comply with safety instructions may be risky for both machine and environment. **MAS DAF MAKİNA SAN. A.Ş.** is not responsible for this kind of damages.

3.2. Hazardous conditions that may occur when one does not comply with the safety instructions

Incompliance with safety regulations may put the personnel, the environment and the machine in danger and thus may cause damages. Incompliance with safety regulations may give rise to situations listed below:

**Important operational functions of the factory may stop
Maintenance may get difficult.
One may get injured by electrical, mechanical or chemical hazards.**

3.3. Safety Measures for Operator

Dangerous, hot or cold components in the pump area must be covered so that one cannot touch them.

Moving components of the pump (such as coupling) must be covered so that one cannot touch them. Those covers must not be dismantled while the pump is running. Dangers that results from electrical connections must be removed. To get more information about this subject, you can refer to VDE and domestic electrical instructions.

3.4. Safety Measures for Maintenance and Installation

The costumer must assure that all maintenance, check and installment tasks are performed by qualified personnel. Repair work must only be performed while the machine is not running.

The pump and its auxiliary system must be cleaned thoroughly if it contains hazardous liquids. At the end of the repair work, all safety and protective equipment must be re-installed.

3.5. Informations about Protection against Explosion

The instructions specified intended for protection against explosion should be noted definitely during commissioning of the pump unit in environments with explosion risk.

Only pumps or pump units having related definitions and adequate suitability must be used in environments with explosion risk. The explosion protection should be noted that it is possible only with the use according to the instructions.



Limit values specified at the ATEX version pump label must not be exceeded definitely.

NOTE: If the categories are different depending on pump and motor temperatures it applies the lowest category.

Ensure that the coupling used for accouplement of motor and pump has ATEX sign.



Avoid all improper commissioning and installation in environments with explosion risk. Otherwise, the pump unit and/or the staff can be exposed to damage/injury. Consider the local explosion protection regulations and the informations at ATEX version pump label.



Check whether ATEX specification on the motor and the pump coincide with specified categories. Consider that if the categories of the pump and the motor are different it applies the lowest category.

3.6. Spare Parts Replacement

Replacement of spare parts and all modifications must be done after contacting with the manufacturer. Spare parts and accessories certified by the manufacturer are important for the safe operation of the system.

Notice: MAS DAF MAKİNA SAN. A.Ş. is not responsible from the usage of improper spare parts.

4. TECHNICAL INFORMATION

4.1. Design

KMU series pumps are non self-priming, horizontal multi stage centrifugal pumps. They have horizontal shaft and closed radial impellers.

4.1.1. Locations of Flange – Flanges

In standard, when one looks from the motor side, suction flange is ahead and on the left, while discharge flange is in the pump side and at the top. With a special order, it is possible to connect the motor on the suction side. In this case, motor shall be required to rotate left. Suction and discharge flanges are in accordance to DIN 2535. Suction opening can be rotated to the right, left and top with a 90° interval.

4.1.2. Auxiliary Fittings

Please refer to the technical drawing of the pump for necessary auxiliary fittings

4.1.3. Impeller

The full radial impellers of closed design are balanced dynamically in an electronic balance machine.

4.1.4. Shaft

In KMU type pumps, precision polished shafts made of 13% chromed stainless steel are used. Pump shaft has the same constant diameter along its length. In this way, it is very easy to mount and dismantle the pump from both sides.

4.1.5. Bearing and Lubrication

Pump is provided from both sides with high temperature resistant, grease lubricated, care-free (6304-2RS-C3 type) rolling bearings.

In order to prevent the leakage flow into the bearing housing, deflectors are provided in front of the bearing covers.

4.1.6. Seals

As standard in KMU type pumps, conventional soft packing is used for sealing. At suction side, seal is provided with a lantern ring.

- Non-cooled packing is standard. (It is acceptable up to 90° C)
- Application of non-cooled mechanical seal is optional. (up to 90 °C)
- Unbalanced mechanical seal is used if the pressure is below 10 bar, whereas balanced mechanical seal is used if the pressure is above 10 bar.
- Cooling with water is optional both for soft packing and mechanical seal applications. (90 -140 °C).

4.2. Construction of Pump Group

4.2.1. Drive

TEFC (Totally Enclosed Fan Cooled) 3 phase, squirrel caged, in accordance to DIN 42673, IMB3 type electrical motor which complies with DIN IEC and VDE is used to drive the pump in proper speed and power.

Specifications of electrical motor

Isolation class	: F
Protection class	: IP 54-IP 55
Frequency	: 50 Hz.
Running type	: S1
Start up type	:

- 1x220V (Monofaze) up to 2 kW or
- 3x380V (Y) up to 4 kW
- More than 4 kW, 3x380(Δ) + (Y/ Δ)

4.2.2. Coupling and Coupling Cover

A flexible shaft coupling with or without secondary component in accordance with DIN 740 is used. A coupling guard is given in accordance with EN 953 in case of the pump group includes the coupling and chassis.



Pump can only be run with a coupling guard in accordance with EN 953 according to safety instructions. If there is no coupling cover, it is provided by the operator.

4.2.3. Base Plate

It is manufactured from steel plate or U profile steel in accordance with DIN 24259.

5. TRANSPORT AND STORAGE

Suction, discharge and all auxiliary fittings must be closed during transport and storage. Dead-end covers must be removed while the pump unit is being installed.

5.1. Transport

Pump and pump group must be carried safely to the installation location by lifting equipments.



Current general lifting safety instructions must be applied. Please use a suspension system shown in figure while you are carrying and lifting the pump unit. The suspension rings may be broken because of the excessive load and may result in a damage of the pump. Prefer fabric cable for suspension.

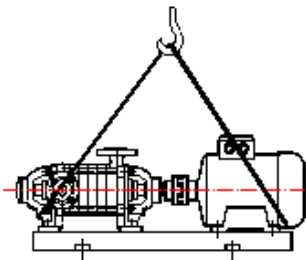

Figure 1: Transport of pump group



Incorrect lifting may damage the pump unit and cause injuries

Damages caused in transport.

Check the pump when it is delivered to you. Please let us know of there is any damage.

5.2. Storage



Please keep the unit clean and dry area during storage.

If the pump is out of use for a long time, please consider the instructions below.

1. If there is water inside the pump, drain it.
2. Clean the pump casing and impeller by jetting clean water for a short time.
3. Empty water inside the pump casing, suction line and discharge line.
4. Add small amount of antifreeze inside the pump casing if it is not possible to empty it completely. Rotate the pump shaft by hand to mix the antifreeze.
5. Close the suction and discharge exits with gasket.
6. Spray an anti-corrosive into the pump casing.
7. Rotate the pump shaft by hand once in every month, in order to protect it from freezing and to lubricate the bearings.

6. ASSEMBLY / INSTALLATION

6.1. Installation

In our standard production, the pump and the motor have been installed in a common base plate.

6.1.1. Location of Installation

Pump shall be installed in a location where the control and the maintenance of the pump are easily made. The pump room shall be suitable for operation of lifting systems such as freight elevator, forklift, etc.

The pump group should be installed in the lowest possible location of the pumping system in order to achieve the highest suction pressure.

6.1.2. Location of Installation - Local Ambient Temperature

When the local ambient room temperature exceeds +40°C in a pumping system, suitable ventilation should be provided in order to remove the heat dissipated to the environment and supply fresh air.

6.2. Type of Connection

Type of connection depends on the design type and the size of the pump and the motor, as well as the local installation conditions. Foot-mounted horizontal pump-motor units have been installed in a common base plate.

6.3. Foundation

6.3.1. General

Base plate of the pump must be grouted. The foundation shall be of concrete or steel framework.

NOTE: The foundation shall distribute the weight of the pumping group evenly.

6.3.2. Main Properties of the Steel Framework Bases

Foundations with steel framework shall be designed in such a way that the base plate is bolted or welded contacting to all area.



If base plate is supported from only four points, pump group will stay in the middle, causing misalignment of the coupling and increasing the noise level.

6.3.3. Foundation Properties

The foundation shall be horizontal, flat and clean and shall support all the weight.

NOTE: Reinforced concrete bases are constructed from standard concrete with at least B 25 resistance class.

6.4.2. Method of Coupling Alignment

In order to make the alignment of the coupling, it is required to have at least two smooth edged metal pieces (e.g. a steel ruler or a gauge stick) and one precision calipers. (Figure 3)
(For more precision alignments, special apparatus can be used).
Coupling misalignments in general are of two kinds:

1.Parallel axis misalignment (Figure4 - Figure 6).

In order to control parallel axis misalignment, a smooth edged gauge stick is pressed axially over the upper half of the coupling. Then, the gauge stick is checked for the other half of the coupling. For alignment, the gauge stick shall be in contact with both of the halves at the same time. This procedure shall be repeated for four sides of the coupling. (i.e., top, bottom, left and right sides of the coupling). When all four sides give reasonably accepted results, alignment of the coupling has been ensured.

2.Angular Misalignment (Figure 5- Figure 7).

In order to control the angular misalignment, the distance between the two halves of the coupling is measured in both horizontal and vertical planes. Measurements taken at four points shall be in agreement for the alignment.

Misalignments can be in horizontal or vertical planes. Misalignments in horizontal plane can be fixed by placing sheet iron at the bottom of the pump or motor base, while misalignments in vertical plane can be fixed by sliding the pump or the motor in horizontal plane.

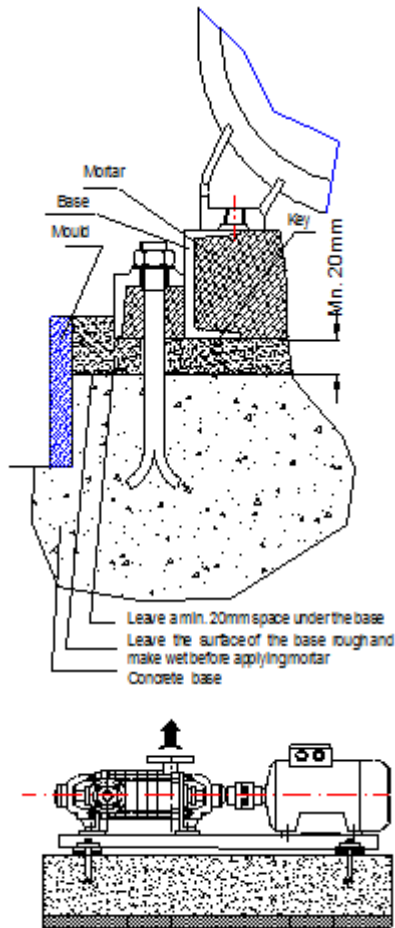

Figure 2: A typical concrete foundation

6.3.4. Fixing (Securing) of Pump Group

After the alignment of the pump group on the foundation has been made, the mutual securing bolt screws should be used alternately to fix the pump group.
All of the area of the base plate should be filled with gout as much as possible.

NOTE: While securing pump group with the mortar bonding agents and molding, one has to make sure that the base plate contacts completely with the base with no cavities between the surfaces. Inside of the chassis (frame) should be completely filled with concrete.

6.4. Coupling Alignment

6.4.1. General

For a proper operation of a pump group, a good alignment of the coupling is necessary. Vibration, noise, overheating of the bearings, overcharge problems can be attributed to the misalignment of coupling or using an improper coupling.



Flexible coupling does not correct the axial misalignments between the pump and the motor axes. However, it allows pinpointing the misalignments.

In order to avoid overheating, vibration, noise and wearing of the rolling bearings, alignment of the coupling has to be made properly and checked often.

Do not use a different coupling other than the original type installed on pumping group.

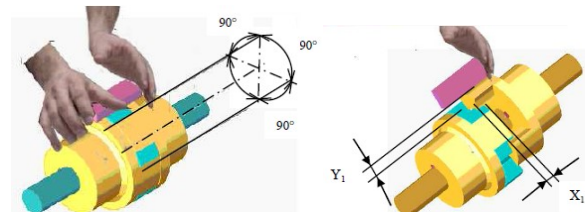

Figure 3: The control of the coupling alignment in horizontal and vertical planes.

Figures below illustrate the possible coupling misalignments and the methods to correct them.

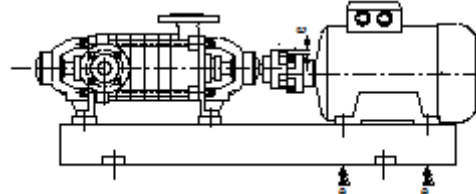

Figure 4: Parallel axis misalignment in vertical plane and its correction

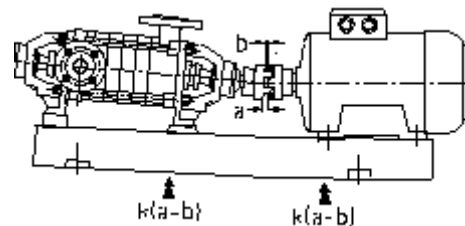

Figure 5: Angular misalignment in vertical plane and its correction

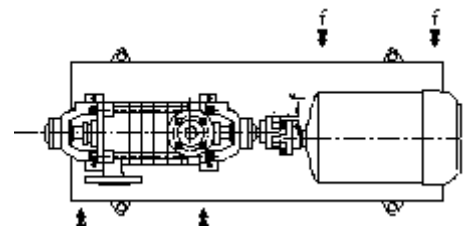

Figure 6: Parallel axis misalignment in horizontal plane and its correction

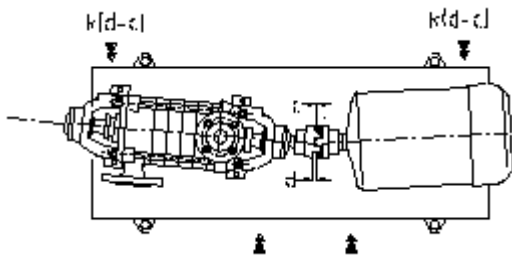

Figure 7: Angular misalignment in horizontal plane and its correction.



Install the coupling guard only when the alignment of the coupling is checked (as in Figure).

6.4.3. Pump and Motor Mounting (Coupling)

If the coupling of the pump group is to be mounted on site, the following procedure should be followed:

1. Coat the shaft tip of the pump and the motor sides with a sheet of molybdenum disulfide.
2. Push the coupling halves with a driving apparatus towards the pump and the motor shafts, until the shaft is fit to snag to the hub of the coupling. If a driving apparatus is not available, heating coupling halves (with coupling rubbers off) to an approximately 100 °C may help the pushing. It is important that axial force is prevented from occurring while mounting the coupling. Support pump shaft from the impeller side, and motor shaft from the fan side while mounting the coupling. If necessary, dismantle the fan cover.
3. Screw the two bolts in coupling hub.
4. Make sure that a suitable spacing is left between the coupling halves while mounting pump and the rotor.
5. Horizontal pump groups mounted on the base plate or directly mounted on the base, alignment of the coupling shall be as described in 6.4.2.
6. Put into place the coupling guard.



According to the accident prevention regulations, all preventions and protective devices should be in their intended place and in operational form.

6.5. Piping

6.5.1. General



- Do not use the pump as the hinged support for the piping system.
- Put enough supports under the piping system in order to carry the weight of the pipe and fittings.
- Avoid piping system loads on pump by installing flexible components (compensator) to suction and discharge of the pump.
- By mounting flexible supporting items, take into consideration the fact that these items may elongate under the pressure. Especially, the supporting items shall be placed in the direction of discharge flange axis of the pump (generally in vertical direction).
- Suction pipe shall be in a constantly increasing slope to the pump. Air in the suction pipe shall be arranged to move into the pump.
- Discharge piping shall be in a constantly increasing slope to the reservoir or discharge point, without up and downs which can cause air pockets in the piping system. At locations where forming of air pockets is possible, special items like air valve and air cock are mounted to evacuate the trapped air.
- It is important that pipe diameter and fittings are at least as much as the pump opening diameter or preferable one or two size higher. One should never use fittings with smaller diameters than the pump exit diameter. In particular, preferred fittings like foot valve, strainer, filter, check valves and valves shall have large free passing area, and low friction loss coefficient.

- For piping systems with hot liquids, thermal expansions are to be taken into account and compensators shall be mounted in accordance with these expansions. Caution shall be exercised to avoid the loading of pump in this installation.

6.5.2. Specification of Work in Piping Installation



In installation of pipes, follow the procedures below certainly.

- Install the pump on the concrete base as illustrated in Figure 2.
- Take out the guards (placed by the manufacturer) from suction and discharge openings of the pump.
- Close the suction and discharge flanges with rubber gaskets. This precaution is important to avoid the undesired substances (weld crust, weld slag, sand, stone, wood piece etc.) get into the pump. Do not take off this gasket until the installation is completed.
- Start the installation of piping from the pump side. Do the necessary assembling and welding of the parts in a successive order.
- In these operations, do not neglect to put the necessary supports in their respected locations.
- Following above procedure, complete all piping system at suction side up to the suction tank (or foot valve if available), at discharge side up to do discharge collector and discharge pipe.
- When all installation and welding process is done and the heat dissipated by welding is removed, dismantle all the bolted connections from the suction tank to discharge pipe. Take out all demountable parts.
- Clean these parts and then paint body coat completely inside and outside.
- Mount the parts again in their intended places. However, this time start from the discharge line and move downward to the pump. In this instance, do not forget to check the flange gaskets. If needed, (for example deformation during welding) replace them.
- Concerning the connection of the pump flanges to piping, in case of misalignment of axis and flange holes, do not force the system to eliminate the misalignment. Forcing the system may cause difficult-to-correct problems.
- If there is an axial misalignment between the flanges of the pump and the pipe, due to the welding or any other reasons, cut the pipe from a suitable location in order to fix the problem. Connect the pipe (pump side) to the pump. After carrying out the necessary correction, connect the parts again by welding.
- Dismantle and clean the last welded part. Repaint again and mount on its place.
- After all these processes are accomplished, remove the rubber gasket from the suction and discharge openings. Open their holes and mount them again on their intended place.

6.5.3. Specification of work after installation of piping and piping system

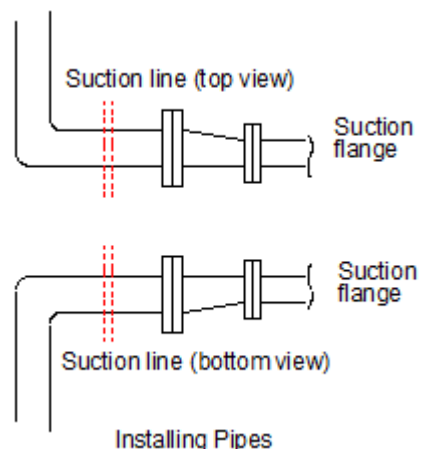

Figure 8: Piping system

An illustrative piping system is shown in Figure 10. Appropriate manometers shall be mounted on suction and discharge pipe lines.



Complete the auxiliary pipe connections in piping system if exist (cooling to bearing housing, and stuffing box (seal), relief pipe, oil pipe etc.)

6.6. Motor Connection

Motor shall be connected by an electrical technician according to the connection (switch) diagram. Local electricity policies and current VDE regulations have to be applied.



- Electrical connections have to be made by authorized electricians.
- In dismantling the pump, make sure the electricity is cut off before taking the motor cover out.
- Use the appropriate electrical connection to the motor

In environments where there is a risk of explosion, prescribed protective law and regulations shall be applied by competent authorities.

Connection points of the cable ends must be away from environment with explosion risk or provide allowable conditions for II 2G device category.



Never operate pump units not connected electrical cable connections correctly.

6.6.1. Motor Connection Diagram

- Motors requiring high moments at start up shall not be connected star-delta
- Frequency controlled motors, require high moment at start up and have to be cooled properly at low speeds. Provide the necessary cooling for the motors.

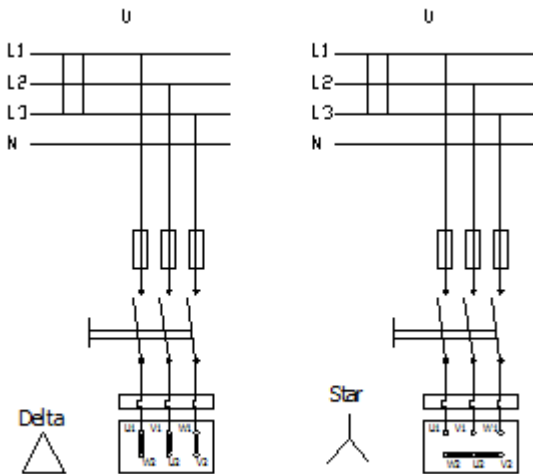

Figure 9: Electric Connection Diagram

Electrical circuit	Motor	
	230/400V	400V
3 x 230V	Delta	-
3 x 400V	Star	Delta

6.6.2. Motor Protection

- Three phased-motor shall be connected to power supply.
- Wait the motor to cool down when thermic protected motor breaks in circuit due to the overheating. Make sure the motor does not start automatically until it cools completely
- In order to protect the motor from overcharging and short circuit use a thermic or thermic-magnetic relay. Adjust this relay to the nominal current of the motor.



Electrical equipments, terminals and the components of the control systems may carry electric current even though they are not operating. They may cause deadly and serious injuries or irreparable material damages.

7. COMMISSIONING, START UP AND OPERATING

7.1. Preparations Before Start-up

Oil Check: Pump is provided from both sides with high temperature resistant, grease lubricated, care-free (2RS type) rolling bearings.

- Check pump seals
- Make sure that the pump and the suction pipe is completely filled with water before the starting. If the pump operates on a positive suction head, no problem will be encountered. Suction valve is opened and air drains are un-tightened.
- Pumps with foot valve are filled with water by opening the pump filling tap or, one takes advantage of the water accumulated in the discharge pipe and by using a small valve the check valve is bypassed and the pump is filled.
- In vacuum pump driven pumps, by operating the vacuum pump one achieves to fill the pump via increasing the water level in the suction pipe.

CAUTION

Do not start your pump dry

7.2. Checking the Direction of Rotation

CAUTION

- The direction of rotation is indicated on the pump label with an arrow. Apart from special cases, it is clockwise direction when looking from the motor end. Observe if the pump is rotating in the expected sense by starting the motor for a very short instant. If it is turning in the opposite sense, interchange any of two motor leads.
- If the motor connection is delta, open the discharge valve slowly.
- If the motor connection is star-delta, set the time relay to maximum 5 seconds. Monitor the passage from star to delta by pressing the start button. As soon as you are assured that the connection is delta, open the discharge valve slowly. Continue opening the valve until you read the amperage on the electrical panel.
- One should always check the labels which show the direction of rotation and the direction of fluid flow. If you dismount the coupling protection to monitor the direction of rotation, do not restart the engine before remounting the protection.



As a result of getting in touch with rotating and stable parts each other temperature increase can occur. Never check the direction of rotation while the pump is dry.

7.3. Start-up Procedure

- Check if the suction valve is open and the discharge valve is closed. Start the motor.
- Wait until the motor reaches sufficient speed. (In Star-delta connections, wait until the engine passes to delta connection.)

- Keeping an eye on the amperage shown on the panel, open the discharge valve slowly.
- In the primary operation, if the discharge pipe is empty, do not open the valve completely. By keeping an eye on the amperage, open the valve with care regarding that it should not exceed the value indicated on pump's label.
- After opening the valve completely, check the pressure from the pump exit manometer and make sure that this value is the pump operating pressure value and is indicated on pump's label.
- If the value one reads is less than the pump label value when the valve is completely open, it means that the height is miscalculated. Increase the value by narrowing the valve and bring it to pump's label value.
- If the value one reads is greater than the pump label value when the valve is completely open, it means that the height is calculated less than what it should be in reality. The device is pumping less than what is requested. Check the installation and the calculations.
- Minimum flow rate: If the pump is working with zero flow rate (closed valve) from time to time during its operation, the water inside the pump may endanger the pump by getting warmed up. In such cases, a minimum flow valve must be connected to the pump exit.
- Gland nuts must not be tightened too much. If the amount of water increases after a long operation time, the nuts may be tightened by 1/6 turns.
- If the pump has mechanical sealing, there is no need for excessive maintenance. Water leakage from the mechanical sealing indicates the fact that the sealing is worn out and therefore needs to be replaced.
- If the system consists of a substitute pump, keep it ready by operating it once a week. Check also the auxiliary systems of the substitute pump.
- Check the elastic components of the coupling. Replace them when necessary.



Occuring explosive ambient inside of the pump must be prevent. The air of the pump and suction line must be drained before commissioning of the pump. The interior of the pump contacting with pumped liquid including gasket way and auxiliary systems must be filled with pumped liquid.

CAUTION

Stop the motor if the pump gets too hot. Wait until it gets cold. Then start the system up again carefully.

7.4. Shut Down Procedure

CAUTION

During sudden start ups and stops, a pressure reducing valve must be placed at the exit section of high flow rate pumps whose discharge pipelines are long, in order to reduce water hammer effect. Water hammer may explode the pump.

In normal conditions (apart from sudden power shut down, etc), stop the pump as below:

- Close the discharge valve slowly
- Switch the power off, stop the motor. Notice that the rotor slows down.
- Do not start up the motor at least before 1 to 2 minutes.
- If the pump will be out of use for a long time, close the suction valve and auxiliary circuits. If the pump is outside and if there exists a danger of frost, remove all drain taps and empty all the water inside the pump (5.2. Storage).



If the pump is outside and if there exists a danger of frost, remove all drain taps and empty all the water inside the pump.

8. MAINTENANCE

CAUTION

- Maintenance operations must be done by authorized personnel with protective clothing only. The personnel must also beware of high temperatures and harmful and/or caustic liquids. Make sure that the personnel reads carefully the manual.
- The instructions in Safety Precautions must be executed during maintenance and repair
- Continuous monitoring and maintenance will increase the engine's and pump's lives.

8.1. The Checks During the Operation

- Pump must never be operated without water.
- Pump must not be operated for a long time with the discharge valve closed (zero capacity).
- Bearing temperature must never exceed 80°C if the ambient temperature is 30°C
- Precautions must be taken against flare up when the component temperatures are over 60°C. "Hot Surface" warnings must be placed over necessary areas.
- All the auxiliary systems must be in use while the pump is operating.
- Water must drop from the glands of stuffing boxes (20-30 drops per minute)

- Ensure that delivery pressure is enough.
- Exceeded the allowable using limits regarding pressure, temperature, transporting material and motor speed may cause explosion risk, hot and poison liquid may leak to external environment.



- Do not operate the pump at values above pressure, temperature or motor speed values specified by manufacturer, never use improper liquids with the pump.

8.1.1. Component Check

CAUTION

To make possible the visual control, one must be able to reach the pump from any direction. Especially, to be able to dismantle the internal units of the pump and the engine, sufficient free space must be created around them for maintenance and repair. Furthermore, one must make sure that the piping system can easily be dismantled.

8.1.1.1. Bearing and Lubrication

Pump is provided from both sides with high temperature resistant, grease lubricated, care-free (6304-2RS-C3 type) rolling bearings. Normal service life of the rolling bearings attains at least the operating hours as declared in DIN ISO 5199 technical specifications.

8.1.2. Shaft Seal Maintenance

8.1.2.1. Packing

- Before replacing the soft packing, the gland must be dismantled first. Used packing rings may be taken off by a sharp pointed tool. Take off the lantern ring if it exists, then clean the interiors of the sealing box, the gland and the lantern ring.
- Wrap a proper sized, good quality sealing over the shaft bush and make sure that the bush tip is completely covered.
- Place the first ring, its joint facing upwards and push it to its bed by using the gland.
- If it exists push the lantern ring to its bed.
- Place also the other rings to their beds alternating, i.e., their joints facing upwards and downwards.
- After placing the last ring, position the gland and tighten it completely. Thus, the squeezed sealing rings take the shape of the sealing box.
- Then un-tighten the nuts. Rotating the shaft tighten them slowly again. When you feel that the shaft is put on a brake, stop the tightening.
- Water must come from the seals drop by drop as soon as the pump is started. The number of drops must not be less than 10 and not more than 30 per minute. Find the proper setting by tightening and un-tightening the opposite gland nuts.



- Ensure that the water leaking from the sealing is collected and/or discharged in a manner which is appropriate in terms of safety and environmental criteria.
- Check the sealing temperature two hours after the gland adjustment is made. For a system which pumps water at ambient temperature, the sealing temperature must not exceed 80°C.



The pumps that working with high temperature liquids has applications on cooling sealing

CAUTION

When tightening the gland nuts do not work with long sleeve shirts. Otherwise it is possible to get caught by the turning shaft and get injured.

8.1.2.2. Mechanical Seal

Mechanical Seals are absolutely leak-tight and needs less maintenance than soft packing.

Mechanical seal;

- 1.Provides leak-proof operation in heavy operating conditions (in waste water pumps, chemical process and refinery pumps).
- 2.Easily mountable and needs less maintenance.
- 3.Does not cause wearing on the shaft
- 4.Sealing operation does not depend on the quality of shaft finishing.

8.1.3. Coupling

As mentioned in Section 6.4, coupling adjustment must be checked regularly.



Worn out elastic bands must be replaced.

8.1.4. Drive

Apply to the operating instructions of the motor manufacturer.

8.1.5. Auxiliary Components

Check regularly the fittings and the gaskets, replace the worn out pieces

8.2. Maintenance Instructions in ATEX Version Pumps



- Consider the local safety instructions and ATEX version pump label specifications.
- During maintenance or repair by taking sparking into consideration, maintain or repair in environments where there is no a possibility of ignition.
- As a result of maintaining deficiently and / or faultily the pump may be damaged and explosion risk may occur. Maintain the pump or the pump unit regularly.
- Carry out maintenance the shaft sealing components properly and regularly. Hot or toxic pumped liquid may leak from the sealing components not maintained regularly. In this case, the damage to the pump, fire and explosion hazards are the likely consequences.
- Fire or explosion hazards may occur as a result of overheating in bearing housings or faulty bearing housing gaskets. Because of that, check the level of lubrication element and periods of lubrication regularly. Check the sounds come from the bearings during the running regularly.

8.3. Service

Our Customer Service Department offers after-sale service. Manager should employ authorized and trained personnel for

mounting/dismounting procedures. Before these procedures, one must make sure that pump interior is clean and empty. This criterion is also valid for the pumps which are sent to our factory or to our service points.



Maintain the safety of the personnel and the environment in every field procedure.

8.4. Spare Parts

The spare parts of KMU type pumps are guaranteed for 10 years by **MAS DAF MAKINA SAN. A. Ş.**

In your spare parts requests, please indicate the below listed values that are indicated on your pump's label.

Pump type and size :
 Motor power and speed :
 Pump serial number :
 Capacity and head :

If you wish to keep spare parts in store, depending on the number of same type of pumps, for two operation years, the quantities which are listed in the table below are recommended.

Component name	The number of equivalent pumps in the installation						
	1-2	3	4	5	6-7	8-9	10 +
Shaft (key included) quantity	1	1	2	2	2	3	% 30
Impeller (quantity)	1	1	1	2	2	3	% 30
Bearings (kit)	1	1	2	2	3	4	% 50
O-ring for casing (kit + 1)	1	1	1	2	2	3	% 40
O-ring for shaft (kit)	1	1	2	2	3	4	% 50
Soft packing (kit)	2	2	2	3	3	4	% 50
Sealing bushes (kit)	1	1	1	2	2	3	% 30
Coupling rubber sleeves (kit)	1	2	2	3	3	4	% 50

9. NOISE LEVEL AND VIBRATION

The reasons which increase the noise level are indicated below:

- Touch of coupling halves due to worn rubber sleeves (incorrectly aligned)
- Noise level increases due to the fact that the pump is not founded properly (Vibration)
- If the installation does not have compensator noise and vibration increases.
- Wearing in ball bearing also increases noise level.



Check if there is any noise increasing elements in your installation.

9.1. Expected Noise Values

Power of Motor PN (KW)	Sound Pressure Level (dB) *	
	Pump with Motor	
	1450 rpm/min.	2900 rpm/min.
< 0.55	64	65
0.75	64	68
1.1	66	68
1.5	67	71
2.2	69	72
3	71	75
4	72	76
5.5	73	84
7.5	74	84
11	75	85
15	76	86
18.5	77	86
22	77	86
30	81	94
37	81	94
45	81	94
55	83	96
75	84	96
90	86	96
110	87	96
132	87	96
160	87	97

(*) Without protective sound hood, measured at a distance of 1 m directly above the driven pump, in a free space above a sound reflecting surface.

The above values are maximum values. The surface noise pressure level at dB(A) unit is shown as (L_{pA}). This complies with TS EN ISO 20361.

10. DISASSEMBLY, REPAIR AND REASSEMBLY



- Before starting work on the pumpset, make sure it is disconnected from the mains and cannot be switched on accidentally.
- Follow the safety precaution measures outlined in "safety instructions".

10.1. Disassembly

- Close all valves in the suction and discharge lines, and drain the pump by opening the drain plugs.
- Remove coupling guard and other safety guards
- Remove pump suction and discharge flanges and all auxiliary supply lines; disconnect the pump from the piping system.
- Disconnect the pump from the driver and detach from the base plate.
- Pull off the coupling half from the shaft (60) using a pull-off device and remove the coupling key (213).



- Before dismantling the pump, number or mark the stage casings, suction and discharge casings and also mark their position in relation to each other to ensure proper reassembly.
- Unscrew nuts of tie bolts and pull the tie bolts (19) out.
- For easy dismantling, proceed with dismantling from the suction end.
- Remove suction end bearing cover (34).
- Remove the retaining ring and spacer sleeve in front of the bearing.
- Unscrew the nuts connecting suction side bearing housing (30.1) to the suction casing (01) and remove bearing housing together with ball bearing.

- Remove suction casing (01) and suction side stuffing box off stage casing group
- Remove in sequence sleeves, impellers, stage casings together with diffusers and final stage diffuser (11).
- Unscrew the nuts connecting discharge casing (05) to the discharge side bearing housing (30.2) and remove the discharge casing.
- Remove the bearing cover (35).
- Remove the retaining ring and spacer sleeve behind of bearing Pull off the discharge side bearing housing (30.2) together with bearing from the pump shaft (60), using a pull-off device.
Clean all the parts, replace damaged or worn-out ones.

10.2. Reassembly

- Reassembly proceeds in reverse sequence to disassembly as described in section F1. You may find the attached drawings useful.
- Coat the seats and screw connections with graphite, silicon or similar slippery substance before reassembly. If you can not find any of the above you may use oil instead (except the pumps for drinking water).



- Never use the old gaskets, make sure the new gaskets and o-rings are the same size as the old ones.
- Start reassembling the pump from the discharge end. Mount the discharge casing (01) to discharge side bearing housing (30.2) and insert the shaft and bearing in its place.
- Reassemble the last stage diffuser (11) and impeller (20). Make sure discharge opening side of the impeller corresponds exactly to the center of the diffuser.
- Reassemble the other stages in sequence carefully. Make sure that O-rings are placed correctly and do not turn.
- Fit the casing studs and tighten them slightly, after placing suction side bearing housing and ball bearing, then place the retaining ring on the shaft.
- Put the pump on a horizontal flat place and by this way arrange the pump foot in a line. As tightening the casing studs carefully and uniformly rotate the rotor by means of coupling. It is necessary to rotate the rotor by hand without any stresses and compulsion.
- Place the pump on the base plate, mount the electric motor, and connect the suction and discharge pipes and auxiliary pipes. Start up the system as shown on part 7.



Check whether the faces contacting with another faces are damaged for avoiding explosion before reassembling of the motor. The parts having deformed faces must be replaced. Ensure that the rotating parts are fitted with the guards

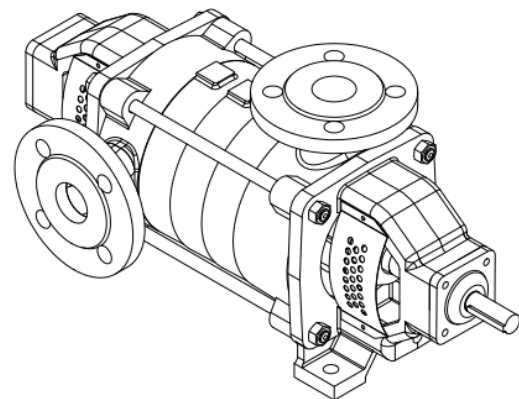

11. POSSIBLE FAILURES, CAUSES, SOLUTIONS

Possible failures and solution strategies are listed in the table below. Please apply to the Customers' Service Department of our company when a generic solution is not found to your problem.



While the failures are repaired the pump must always be dry and un-pressurized.

POSSIBLE FAILURE	CAUSES	SOLUTIONS
1) The pump delivers insufficient capacity	<ul style="list-style-type: none"> Discharge head too high Very high counter pressure Pump and/or pipe cannot discharge air, cannot suck Occurrence of air pockets inside the pipe NPSH is too low 	<ul style="list-style-type: none"> Readjust the operating point See if there is any undesired material inside the pipe Vent completely the pump and the pipe Change the piping configuration Increase the liquid level
2) Motor overload	<ul style="list-style-type: none"> System pressure is lower than the requested pressure level Speed too high Liquid pumped of different specific gravity and viscosity than that for which pump is rated Engine works at two phases 	<ul style="list-style-type: none"> Adjust the operating pressure to the label value Decrease the speed Increase the engine power Replace the fuse and control the electrical connections
3) Pump head is too high	<ul style="list-style-type: none"> System pressure is higher than the requested pressure level 	<ul style="list-style-type: none"> Set the operating pressure to the label value
4) Bearing temperatures are high	<ul style="list-style-type: none"> Worn out coupling Too much, too little or improper lubrication Increase in axial forcing 	<ul style="list-style-type: none"> Replace the coupling Change the oil, decrease or increase its quantity Clean the balance holes on the impeller disc
5) Excessive leakage from the stuffing box	<ul style="list-style-type: none"> Worn out gland Loose gland 	<ul style="list-style-type: none"> Use brand new gland Change the stuffing bush Tighten the gland nuts
6) Noisy operation	<ul style="list-style-type: none"> Worn out motor or pump ball bearings Cavitation Worn out or misaligned coupling Operation in the far left or right of the performance curve 	<ul style="list-style-type: none"> Replace Close the delivery partially in order to reduce the capacity. Replace the coupling or align it Operate the pump at its label setting
7) Excessive increase in pump temperature	<ul style="list-style-type: none"> Pump and/or pipe can neither discharge, nor aspirate air Too low capacity 	<ul style="list-style-type: none"> Bleed completely the pump and the pipe Open more the valve
8) Vibration	<ul style="list-style-type: none"> Pump and/or pipe can neither discharge, nor aspirate air NPSH is too low Internal components of the pump are worn out System pressure is lower than the requested pressure level Coupling is misaligned Too much, too little or improper lubrication Rotor unbalanced Improper bearings 	<ul style="list-style-type: none"> Bleed completely the pump and the pipe Increase the liquid level Replace the worn out components Adjust the operating pressure to the label value Align the coupling In case of continuous overload, decrease the impeller diameter Change the oil, decrease or increase its quantity Balance the impeller again Use new bearings

12. PUMP DIMENSIONS TABLE AND WEIGHTS

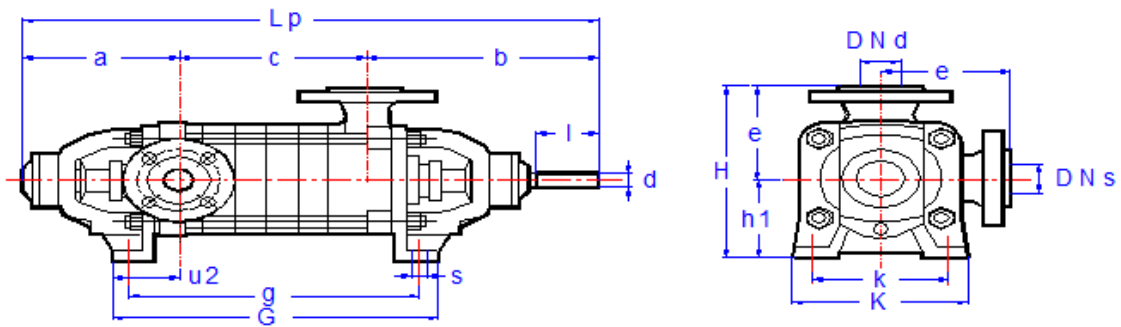

No	Pump Type	DN Suction	DN Discharge	a	b	C - Stage x L4	Stage Length	g-C	G-c	u2	h1	e	d(ø)	l	k	K	s(ø)	2900		Pump Without Driver		
																		Min. Stage	Max. Stage	Min. Stage Weight (Kg)	Stage Weight (Kg)	Max. Stage Weight (Kg)
1	KMU 25	25	25	160	218	31	32	135	160	78	100	125	20	50	125	158	14	2	18	34	3	79
2	KMU 32	32	32	160	218	31	32	135	160	78	100	125	20	50	125	158	14	2	18	36	3	81
3	KMU 40	40	40	160	210	26	40	140	170	85	112	145	20	50	139	170	14	2	14	41,5	4,5	91
4	KMU 50	50	50	160	210	26	40	140	170	85	112	145	20	50	139	170	14	2	14	43,5	4,5	93

13. TIGHTENING TORQUES

Thread Diameter	Tightening Torque Max (Nm)	
	Property Classes	
	8.8	10.9
M4	3.0	4.4
M5	5.9	8.7
M6	10	15
M8	25	36
M10	49	72
M12	85	125
M14	135	200
M16	210	310
M18	300	430
M20	425	610
M22	580	820
M24	730	1050
M27	1100	1550
M30	1450	2100
M33	1970	2770
M36	2530	3560

14. FORCES AND MOMENTS AT THE PUMP FLANGES

All of the applied loads if not reached the maximum allowable value, to provide that the following additional conditions, one of these loads may exceed the normal limit:

- Any component of a force or a moment, must be limited 1.4 times of the maximum allowable value,
- The actual force and moments acting on each flange, should provide the following formula:

$$\left(\frac{\sum |F|_{\text{actual}}}{\sum |F|_{\text{maximum allowable}}} \right)^2 + \left(\frac{\sum |M|_{\text{actual}}}{\sum |M|_{\text{maximum allowable}}} \right)^2 \leq 2$$

In here, $\sum |F|$ and $\sum |M|$ are arithmetic sum of the loads for each flange at the pump level, without regard of the algebraic signs of the actual and maximum allowable values.

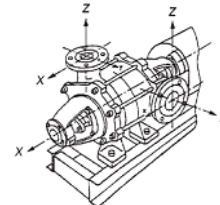

Pump Type	DN Flange		Forces						Moments	
			Suction Flange			Discharge Flange			Suction Flange	Discharge Flange
	Suction	Discharge	N			N			Nm	Nm
			Fy	Fz	Fx	Fy	Fz	Fx	M	M
KMU 25	25	25	243	200	214	200	243	214	280	280
KMU 32	32	32	300	243	257	243	300	257	385	385
KMU 40	40	40	357	286	314	286	357	314	490	490
KMU 50	50	50	471	386	429	386	471	429	543	543

Forces at the pump flanges were calculated according to TS EN ISO 5199 standard. The calculations are valid for the materials of cast iron and bronze. Forces and moments at the flanges that made of stainless material will be approximately twice as moments in the table.

15. SAMPLE PIPEWORK

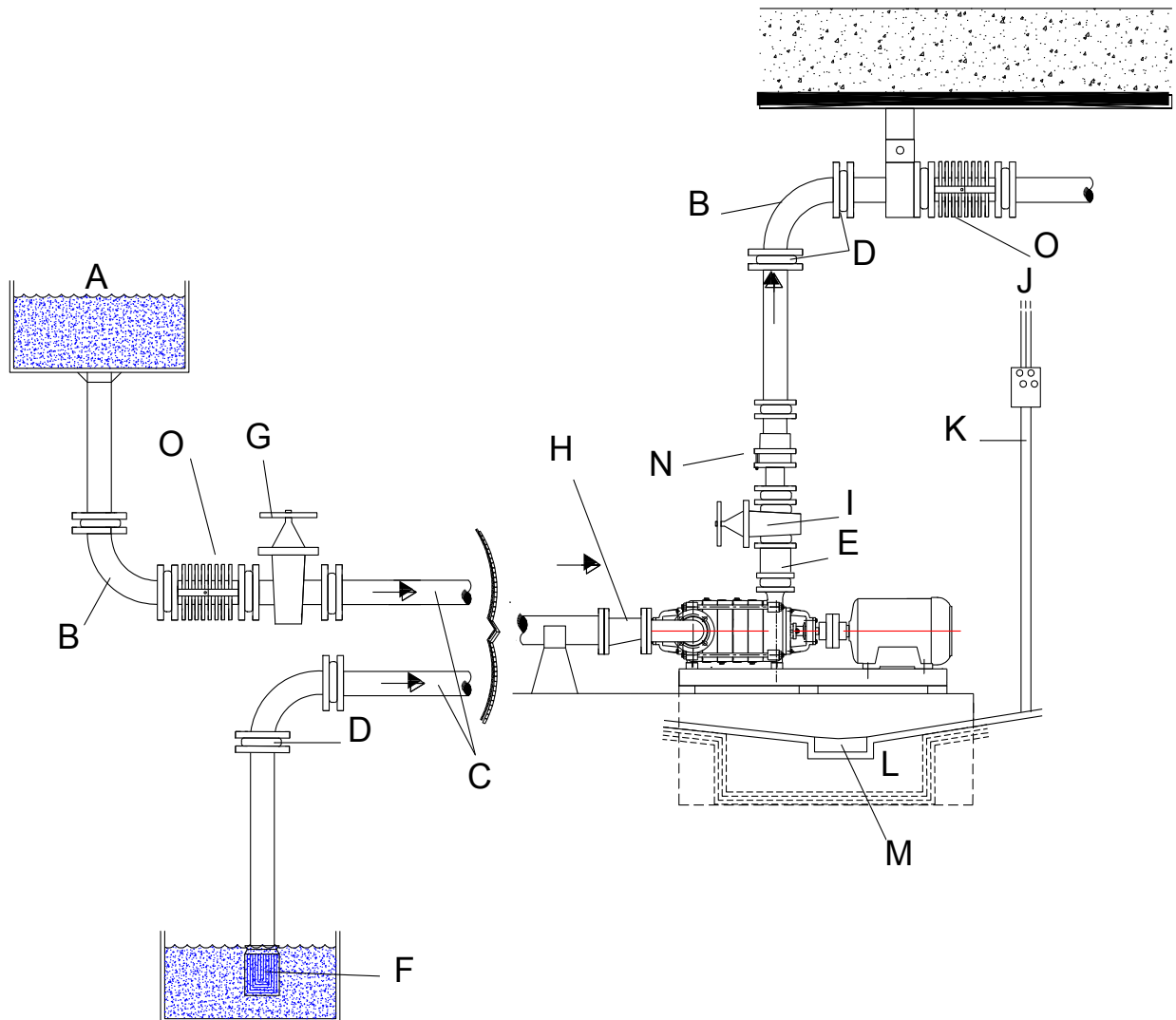

Figure 10. A typical piping

- A. Tank
- B. Large radius elbow
- C. Minimum slope is 2 cm/m
- D. Fittings, flanges etc.
- E. Non-return valve
- F. Foot valve
- G. Suction valve
- H. Reducer
- I. Discharge valve
- J. Electrical connection
- K. Insulated cable
- L. Concrete foundation
- M. Dirty water groove
- N. Compensator
- O. Compensator

16. KMU SECTIONAL DRAWING AND SPARE PART LIST

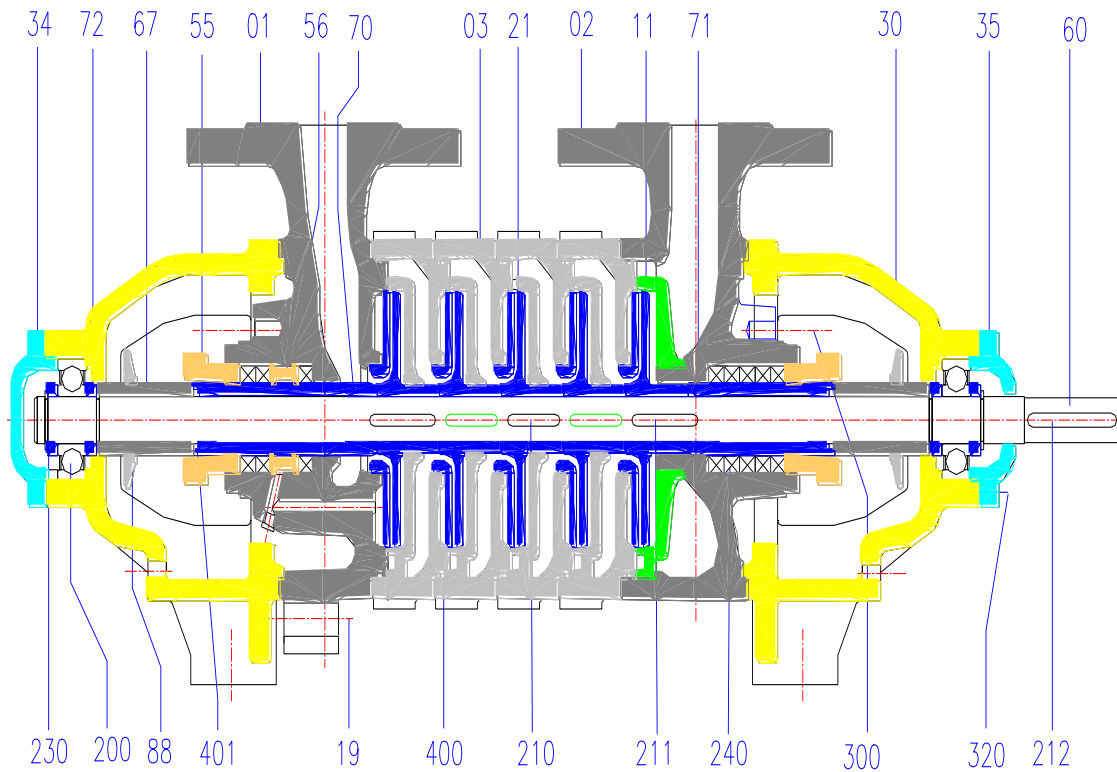

Figure 11 Soft Packing Design

Spare Part List

Part No	Part Name	No	Part Name
01	Suction casing	88	Deflector
02	Discharge casing	200	Rolling bearing (6304-2RS)
03	Stage casing	210	Impeller keys
11	Last stage diffuser	211	First and last stage keys
19	Casing stud and nut	212	Coupling key
21	Impeller	230	Shaft ring
30	Bearing casing	240	Soft packing
34	Bearing cover (suction)	300	Gland stud and nut
35	Bearing cover (discharge)	320	Bearing cover bolt
55	Gland	400	O-ring (stage casing)
56	Lantern ring	401	O-ring (shaft sleeve)
60	Pump shaft		
67	Intermediate bush		
70	Shaft sleeve (suction)		
71	Shaft sleeve (discharge)		
72	Bearing bush		

17. ALTERNATIVE APPLICATIONS

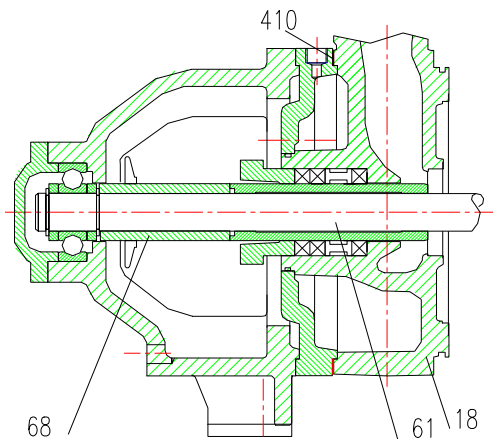

Figure 12: Design with cooling stuffing box.

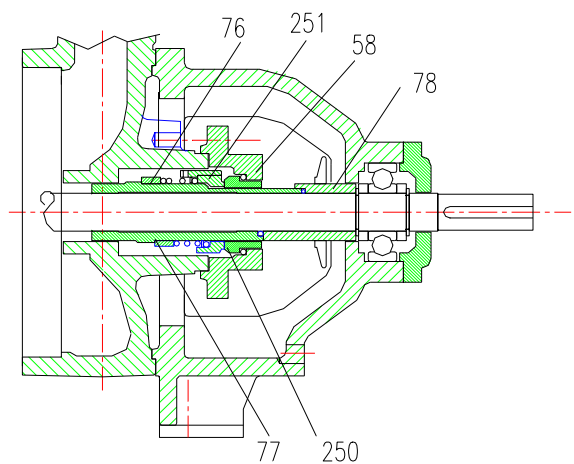

Figure 13: Design with balanced/unbalanced mechanical seal

- Cooling stuffing box (it can also be a cooling mechanical seal)

- 68 Long intermediate bush
- 18 Cover for cooling cell
- 61 Special pump shaft
- 410 Gasket

- Upper half picture: **Balanced mechanical seal** (Part Nr. 251) (for discharge side : for pressure above 10 bar)
- Lower half picture: **Spring actuated mechanical seal** (Part Nr. 250) (For suction side and discharge side when pressure is less than 10 bar)

- 76 Shaft bush for balanced mechanical seal
- 58 Mechanical seal cover
- 78 Intermediate bush for balanced mechanical seal
- 77 Shaft bush for spring actuated mechanical seal

18. DIFFERENT INSTALLATION APPLICATIONS

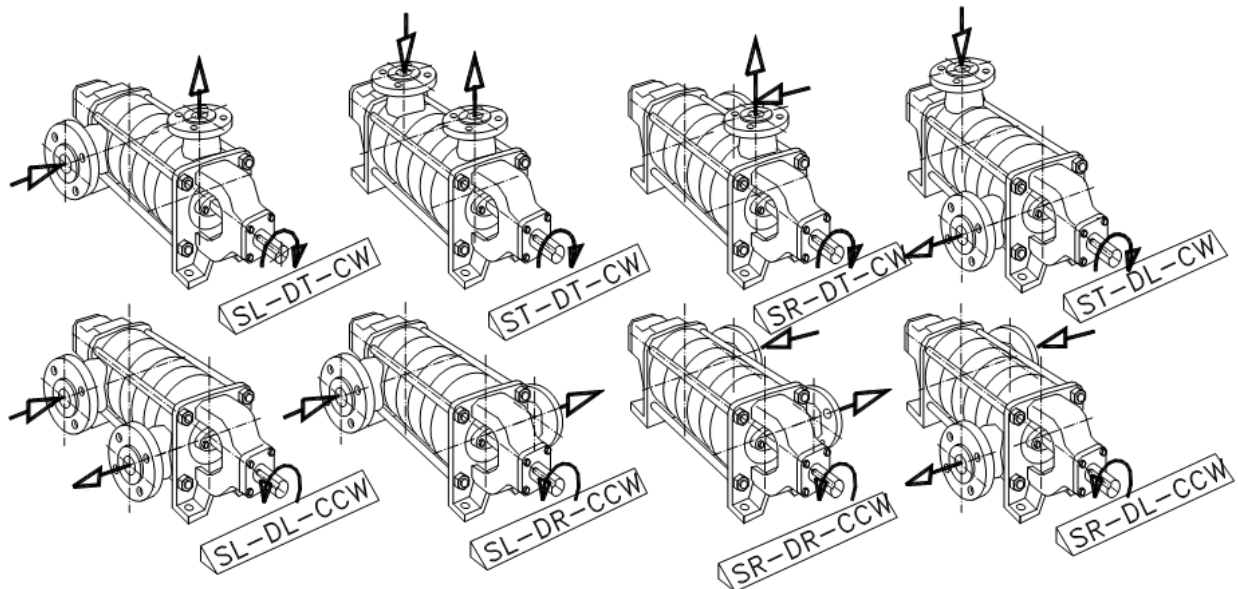

Example: SL-DT-CW (SL: Suction Left -DT: Discharge Top- CW: Clock-wise rotation)

19. KMU DRAWING FOR DISMANTLING

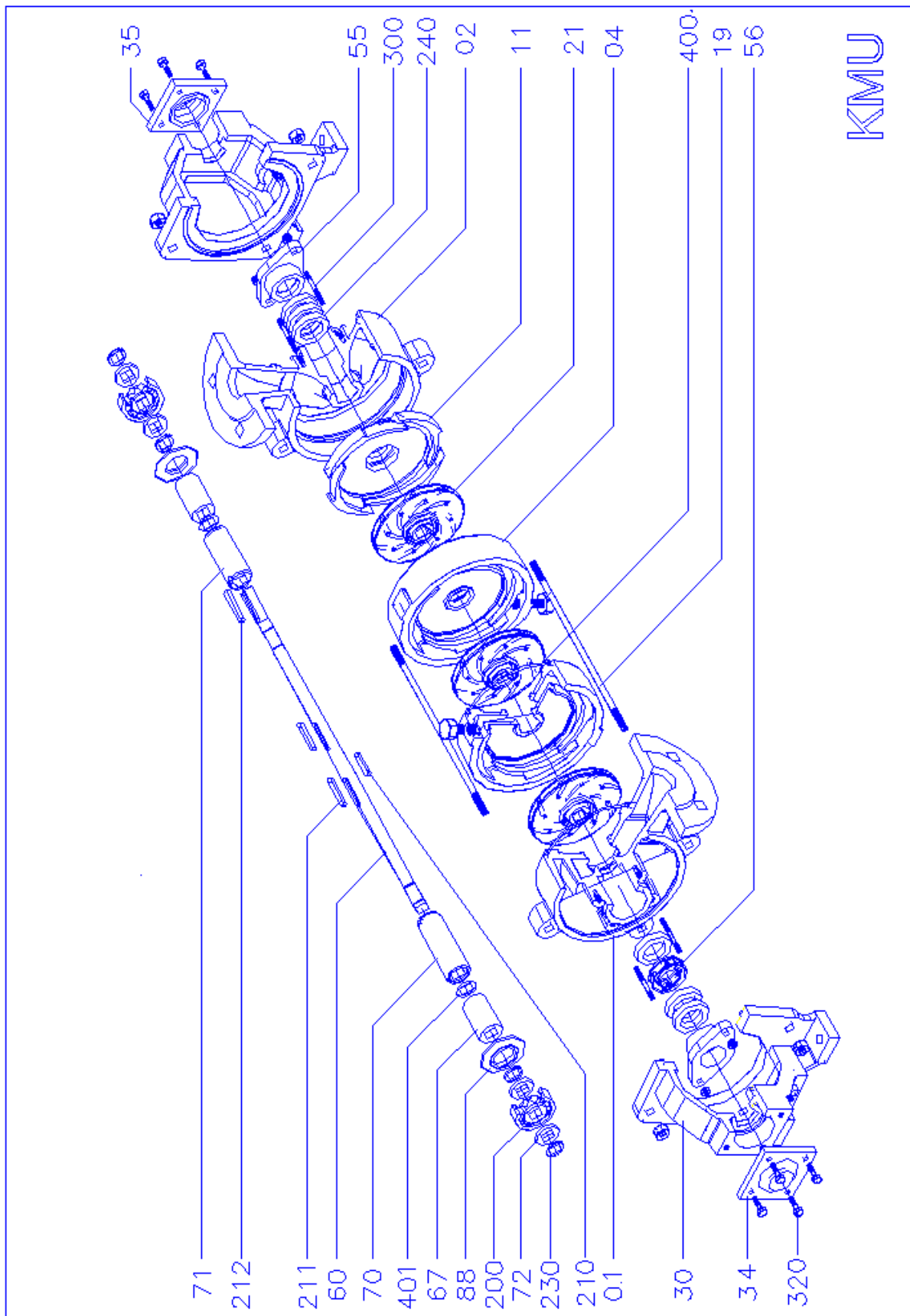



Mas Grup

Head Office / Center Service:

Aydınlı Mah. Birlik OSB. 1.No'lu Cadde No:17 Tuzla - İSTANBUL / TÜRKİYE
Tel: +90 (216) 456 47 00 pbx Fax: +90 (216) 455 14 24

Ankara Regional Directorate:

Aşağı Öveçler Mah. 1329 Sok. No:6/9 Öveçler ANKARA / TURKEY
Tel: +90 (312) 472 81 60-67 Fax: +90 (312) 472 82 51

Factory:

1. Organize Sanayi Bölgesi Parsel 249/5 Beyköy - DÜZCE / TÜRKİYE
Tel: +90 (380) 553 73 88 Fax: +90 (380) 553 71 29