

Monoblok Centrifugal Pumps

NMM SERIES



OPERATING MANUAL





EC DECLARATION OF CONFORMITY

AT UYGUNLUK BEYANI

Manufacturer / İmalatçı : MAS DAF MAKİNA SANAYİ A.Ş.

Address / Adres : Aydınlı Mah. Birlik OSB. 1.No'lu Cadde No:17 Tuzla - İSTANBUL / TÜRKİYE

Name and address of the person authorised to compile the technical file Vahdettin YIRTMAÇ
Aydınlı Mah. Birlik OSB. 1.No'lu Cadde No:17 Tuzla - İSTANBUL / TÜRKİYE
Teknik Dosyayı Derleyen Yetkili Kişi ve Adresi

The undersigned Company certifies under its sole responsibility that the item of equipment specified below satisfies the requirements of the mainly Machinery Directive 2006/42/EC which is apply to it.

The item of equipment identified below has been subject to internal manufacturing checks with monitoring of the final assessment by MAS DAF MAKİNA SANAYİ A.Ş.

Aşağıda tanımlanmış olan ürünler için Makine Emniyeti yönetmeliği 2006 / 42 / AT' nin uygulanabilen gerekliliklerinin yerine getirildiğini ve sorumluluğun alınmış olduğunu beyan ederiz.

Aşağıda tanımlanan ürünler içüretim kontrollerine bağlı olarak MAS DAF MAKİNA SANAYİ A.Ş. tarafından kontrol edilmiştir.

Equipment / Ürün : Monoblok Santrifuj Pompalar - Monoblok Centrifugal Pumps

Seri / Model-Tip : NMM Serisi – NMM Series

For pumps supplied with drivers/ Elektrikli Pompa Üniteleri

Related Directives / Yönetmelikler

2006/42/EC Machinery Directive / 2006/42/AT Makine Emniyeti Yönetmeliği

2014/35/EU Low Voltage Directive / 2014/35/AB Alçak Gerilim Yönetmeliği

2014/30/EU Electromagnetic Compatibility Directive / 2014/30/AB Elektromanyetik Uyumluluk Yönetmeliği

EUP 2009/ 125 /EC Electric Used Products Directive/ Elektrik Kullanan Ekipmanlar Direktifi (EUP)

94/9/EC Equipment For Explosive Atmospheres / Patlayıcı Ortamlardaki Ekipman Yönetmeliği

2009/125/EC European Ecodesign Directive, Regulation No: 547/2012 Ecodesign Requirements for Water Pumps / Avrupa

Ekotasarım Direktifi, (SGM-2015/44) 547/2012 No'lu Su Pompalarında Ekotasarım Regülasyonu

Regulations applied acc. to harmonize standards / Uygulanan Uyumlaştırılmış Standartlar

TS EN ISO 12100:2010, TS EN 809+A1, TS EN 60204-1:2011.

We hereby declare that this equipment is intended to be incorporated into, or assembled with other machinery to constitute relevant machinery to comply with essential health and safety requirements of Directive The machinery covered by this declaration must not be put into service until the relevant machinery into which it is to be incorporated has been declared in conformity with provisions of the directive.

Ekipman, uygun bir makina oluşturmak amacıyla diğer ekipmanlar ile birleştirilirken yada monte edilirken gerekli sağlık ve güvenlik yönetmeliklerine uyulması gerekmektedir.

Bu bildiri kapsamında yönetmelikte belirtilen bütün hükümler yerine getirilmeden makinanın devreye alınması gerekmektedir.

Place and date of issue / Yer ve Tarih : İstanbul, 02.06.2014

Name and position of authorized person : Vahdettin YIRTMAÇ
Yetkili Kişinin Adı ve Görevi : General Manager / Genel Müdür

Signature of authorized person
Yetkili Kişinin İmzası

TABLE OF CONTENTS

Page No

Introduction	1
1.Important Safety Precautions	1
2.General	1
3.Safe Operating Conditions	2
4.Technical Information	3
5.Transport and Storage	3
6.Assembly/Installation	4
6.1. Installation	4
6.2. Fixing (Securing) Of Pump Group	4
6.3. Piping	4
6.4. Motor Connection	5
7.Commissioning, Start up and Operating	5
7.1. Preparations Before Start up	5
7.2. Checking The Direction of Rotation	5
7.3. Start up Procedure	5
7.4. Shut Down Procedure	6
8.Maintenance	6
8.1. The Checks During the Operation	6
8.2. Service	6
8.3. Spare Parts	7
9.Noise Level and Vibration	7
10. Disassembly, Repair and Reassembly	8
11. Possible Failures, Causes, Solutions	9
12. Pump Dimensions Table	10
13. Tightening Torques	14
14. Forces And Moments at The Pump Flanges	15
15. Sample Plumbing	16
16. NMM Sectional Drawing and Part List	17
17. NMM Drawing for Dismantling	19
18. NMM Series MEI Value Tables	21
19. Figure List	22
20. Table List	22

The Signs Used in This Operation Manual



Read the instructions carefully in this operating manual and keep it for your future reference.



Warning sign against the electrical risks



Sign for the operator's safety

1. IMPORTANT SAFETY PRECAUTIONS

In order to minimize the accidents during the mounting and putting into service of the pump, the following rules have to be applied:

1. Do not work without taking safety measures relevant to equipment. Cable, mask and safety band must be used when necessary.
2. Be sure there is adequate amount of oxygen and there is no toxic gaseous around
3. Before using welding or any electrical equipment make sure that there is no risk of explosion.
4. Check the cleanliness of the area to take care of your help. (Dust, smoke, etc.)
5. Do keep in mind that there is a risk of having accidents related to electricity
6. Do not lift the pump before you check the transport equipment.
7. Be sure you have a by-pass line
8. Use helmet, eye glasses and protective shoes for your safety
9. Place a protective barrier around the pump within the necessary safety area
10. Dust, liquids and gaseous that may cause overheating, short circuit, corrosion and fire must be kept away from the pump unit.
11. By checking the noise level of the pump unit, necessary measures to avoid noisy operation of the pump that can have harmful effects on the personnel and environment.
12. Be careful about the direction of transport and storage.
13. Cover appropriately the moving parts to avoid possible injury of the personnel. Mount the coupling guard and belting before starting-up the pump
14. All the electrical and electronic applications must be performed by authorized person conforming EN60204-1 and /or domestic instructions.
15. Protect the electrical equipment and motor against overloading
16. If flammable and explosive liquids are pumped, ground connection of electricity should be carried out properly
17. Do not expose the pump unit to sudden temperature variations
18. All personnel who work with the waste water system need to be vaccinated in case of contagious diseases.
19. If the pump contains hazardous liquids, one must use protective helmet against the risk of splatter. One also must accumulate the liquid in a proper container against any risk of leakage.

All Other Health and Safety Rules, Laws and Regulations Must Be Applied

2. GENERAL

2.1. Definition of Pump and Usage Areas

NMM series pumps are single stage, close coupled volute type pumps. They are used in

- Water networks and pressurization facilities
- Irrigation, sprinkling and drainage systems
- Filling –Draining of tanks and reservoirs
- Hot and Cold water circulation in heating and cooling systems.
- Condense water pumping
- Water circulations in pools
- Health purification facilities
- Industrial and social facilities
- Fresh and sea water pumping in ships.

They shall be used to pressurize liquids (up to 120°C) which are clean or mildly impure, non abrasive, and not containing large solid particles or fiber.

INTRODUCTION



- This manual contains instructions for the installation, operation and maintenance of the NMM type horizontal single stage, non-self priming centrifugal pumps of **MAS DAF MAKINA SANAYI A.Ş.**
- Please read carefully this manual and apply all the instructions to operate pumps without problems. Pumps shall be used for their intended duties. In this manual, there are information on operating conditions, installation, starting-up, settings and main controls of pumps.
- These operating and maintenance instructions contain **MAS DAF MAKINA SANAYI A.Ş.**'s suggestions. The special operating and maintenance information of the plumbing that a pump is fitted to is not considered in these instructions. This information must be given by the plumbing constructors only.
- **Please refer to instructions of plumbing constructors.**
- Please pay attention to the warnings in this manual and ensure that it is read before the installation-start up process. **MAS DAF MAKINA SANAYI A.Ş.** is not responsible for the accidents resulting from negligence.
- If you cannot find an answer to your questions in this manual, it is suggested that you contact **MAS DAF MAKINA SANAYI A.Ş.** Please inform us about the rated value and especially the serial number of the pump when you get in contact for help.
- The safety instructions in this manual cover the current national accident protection regulations. Beside all of these, an operation, work and safety measure imposed by the costumer has to be applied.

CAUTION

Please contact MAS DAF MAKINA SANAYI A.Ş. for liquids that have different chemical and physical specifications.

NMM type centrifugal pumps are comprised of 29 types which conform to DIN 24255 (EN 733) standards.

Technical specifications of NMM type pumps

Suction Flange:	DN 50 – DN 150
Discharge Flange:	DN 32 – DN 125
Operating Pressure:	10 Bar
Operating Temperature:	-25 – 120°C
Capacity:	5 – 400 m ³ / h
Hm:	4 - 110 m
Speed:	1450 – 2900 RPM

Product Information as per Regulation No. 547/2012 (for Water Pumps with a Maximum Shaft Power of 150 kW) Implementing "Ecodesign" Directive 2009/125/EC

Minimum Efficiency Index for MAS NMM Pump Series is shown on the pump label.

MEI values of MAS NMM Pump Series are shown on the pump characteristic curves.

Minimum Efficiency Index for MAS NMM Pump Series; Minimum 0.4. (MEI≥0,4)

Efficiency values of the pump characteristic curves, which are cut diameter, are expressed in %.

NMM Series water pumps, the pump efficiency can be achieved more than fix speed in case of variable speed control.

More information about the Ecodesign can be reached at www.europump.org

2.3. Warranty Conditions

The entire products in our selling program are warranted by MAS DAF MAKINA SANAYI A.Ş.

The warranty conditions will only be valid when all the instructions about installation and start-up operations of the pump unit are taken into account.

2.4. Test

All Pumps are dispatched for sale when all the performance and pressure tests are completed. Proper assurance of material and fault-free operation of pumps whose performance tests are made is under the warranty of MAS DAF MAKINA SANAYI A.Ş.

2.5. Pressure Limit



Pressure at the discharge flange must not exceed 10 Bar. A special order is necessary for applications with higher pressures.

3. SAFE OPERATING CONDITIONS

This manual contains main safety instructions for the installation, operation and maintenance. It must be read by the personnel who are responsible for installation and operation. This manual should always be kept near the installation location. It is important to comply with safety precautions stated in page 1 along with the general safety instructions as well as preventive measures repeated in other sections of this manual.

3.1. Training of Personnel

Installation, operation and maintenance personnel must have necessary knowledge in order to accomplish the given job. The responsibility, adequacies and controlling duties of such personnel must be determined by the costumer. It has to be certain that these personnel comprehend totally the content of the operating manual.

If the personnel do not have enough knowledge, required training must be given by the costumer. If training support is needed by the costumer, it will be provided by the manufacturer/seller.



Untrained personnel and unwillingness to comply with safety instructions may be risky for both machine and environment. MAS DAF MAKINA SANAYI A.Ş. is not responsible for this kind of damages.

3.2. Hazardous Conditions That May Occur When One does not Comply With the Safety Instructions

Incompliance with safety regulations may put the personnel, the environment and the machine in danger and thus may cause damages. Incompliance with safety regulations may give rise to situations listed below.

- Important operational functions of the factory may stop.
- Maintenance may get difficult.
- One may get injured by electrical, mechanical or chemical hazards.

3.3. Safety Measures for Operator

Dangerous, hot or cold components in the pump area must be covered so that one cannot touch them.

Moving components of the pump must be covered so that one cannot touch them. Those covers must not be dismantled while the pump is running. Dangers that results from electrical connections must be

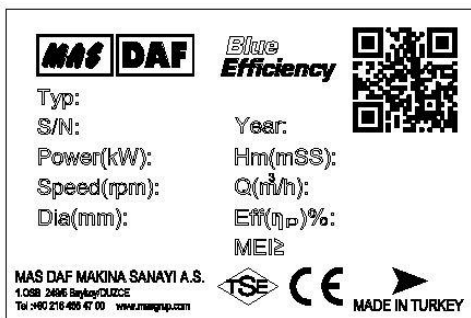

Figure 1: Pump Label

2.2. Performance Information

Actual performance of the pump can be obtained from the order page and/or from the test report. This information is given on the pump label.

The performance curves given in the catalog are valid for water whose density and viscosity are $\rho=1 \text{ kg/dm}^3$ and $\nu=1 \text{ cst.}$ respectively. For those liquids whose densities and viscosities are different from those of water, please consult with MAS DAF MAKINA SANAYI A.Ş. since the performance curves vary with density and viscosity



Do not operate the pump with a motor that has a different power except for the given catalog and label values.

The pump is not to be operated at off-design point given in the order and supplied from the firm.

It is necessary to ensure that the instructions are obeyed for the safe running of the pump.

removed. To get more information about this subject, you can refer to domestic electrical instructions.

3.4. Safety Measures for Maintenance and Installation

The customer must assure that all maintenance, check and installation tasks are performed by qualified personnel. Repair work must only be performed while the machine is not running. The pump and its auxiliary system must be cleaned thoroughly if it contains hazardous liquids. At the end of the repair work, all safety and protective equipment must be re-installed.

3.5. Spare Parts Replacement

Replacement of spare parts and all modifications must be done after contacting with the manufacturer. Spare parts and accessories certified by the manufacturer are important for the safe operation of the system.

Notice: MAS DAF MAKINA SANAYI A.Ş. is not responsible from the usage of improper spare parts.

4. TECHNICAL INFORMATION

4.1. Design

These are close coupled, single stage, single suction with a horizontal opening and a vertical discharge opening volute type (with horizontal shaft) pumps. They have closed radial impellers and their casing sizes are in accordance to DIN 24255 and EN 733 standards.

4.1.1. Locations of Flange – Flanges

Suction Flanges: In axial direction	DN50-DN150
Discharge Flanges: Radially upward	DN32-DN125
Standard of Flanges:	TSE EN 1092-2

4.1.2. Connection of Pump and Motor

Motor is close coupled to the pump with a rigid coupling using an adapter and flange. In this way, the shafts of the motor and pump constitute a complete unit.

4.1.3. Impeller

The closed radial type impeller of the pump is balanced dynamically in an electronic balance machine. The thrust (axial force) is balanced with the back wear ring and balance holes.

4.1.4. Shaft

The shaft, impeller and other parts of the pump is designed to be dismountable without moving (dislodge) the suction and discharge pipes and volute of the pump. In this way, the installation and maintenance operations can be performed very easily.

4.1.5. Bearing and Lubrication

Rolling bearings are not used in NMM type pumps. Motor bearing is enough for countervailing all axial and radial forces.

4.1.6. Seals

In standard production, various mechanical seal types (e.g. bellow type, spring actuated type) are used for sealing.

4.2. Construction of Pump Group

4.2.1. Drive

TEFC (Totally Enclosed Fan Cooled) 3 phase, squirrel caged, in accordance to DIN 42673, IM 1001B3 type electrical motor which complies with DIN IEC and VDE is used to drive the pump in proper speed and power.

Specifications of electrical motor;

- Isolation class : F
- Protection class : IP 54-IP 55
- Frequency : 50 Hz
- Running type : S1
- Start up type : Up to 4 kW, 3x380 V (Y)
More than 4 kW, 3x380V (Δ)+(Y/ Δ)

4.2.2. Coupling and Coupling Guard

In NMM type pumps, a clamped type rigid coupling is used. A coupling guard is provided in accordance with EN 294 in the rigid coupling area.



Pump can only be run with a guard in accordance with EN 294 according to safety instructions. If there is no cover, it is provided by the operator.

5. TRANSPORT AND STORAGE

Suction, discharge and all auxiliary fittings must be closed during transport and storage. Dead-end covers must be removed while the pump unit is being installed.

5.1. Transport

Pump and pump group must be carried safely to the installation location by lifting equipments.



Current general lifting safety instructions must be applied. Please use a suspension system shown in figure while you are carrying and lifting the pump unit. The suspension rings may be broken because of the excessive load and may result in a damage of the pump. Prefer fabric cable for suspension.

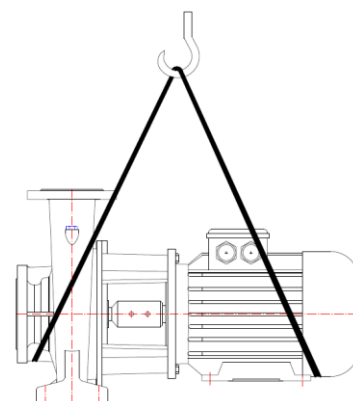

Figure 2: Transport of Pump Group



Incorrect lifting may damage the pump unit and cause injuries.

Damages caused in transport

Check the pump when it is delivered to you. Please let us know of there is any damage.

5.2. Storage



Please keep the unit clean and dry area during storage.

If the pump is out of use for a long time, please consider the instructions below.

- 1.If there is water inside the pump, drain it.
- 2.Clean the pump casing and impeller by jetting clean water for a short time.
- 3.Empty water inside the pump casing, suction line and discharge line.
- 4.Add small amount of antifreeze inside the pump casing if it is not possible to empty it completely. Rotate the pump shaft by hand to mix the antifreeze.
- 5.Close the suction and discharge exits with gasket
- 6.Spray an anti-corrosive into the pump casing.
- 7.Rotate the pump shaft by hand once in every month, in order to protect it from freezing and to lubricate the bearings.

6. ASSEMBLY / INSTALLATION

NMM type close coupled pumps are mounted to the ground by foots of the volute and also fixed to the ground with a supporting pedestal at the bottom of the motor.

6.1. Location of Installation

Pump shall be installed in a location where the control and the maintenance of the pump are easily made. The pump room shall be suitable for operation of lifting systems such as freight elevator, forklift, etc.

The pump group should be installed in the lowest possible location of the pumping system in order to achieve the highest suction pressure.

6.1.1. Location of Installation- Local Ambient Temperature

When the local ambient room temperature exceeds +40°C in a pumping system, suitable ventilation should be provided in order to remove the heat dissipated to the environment and supply fresh air.

6.2. Fixing (Securing) Of Pump Group

After the alignment of the pump group on the foundation has been made, the mutual securing bolt screws should be used alternately to fix the pump group.

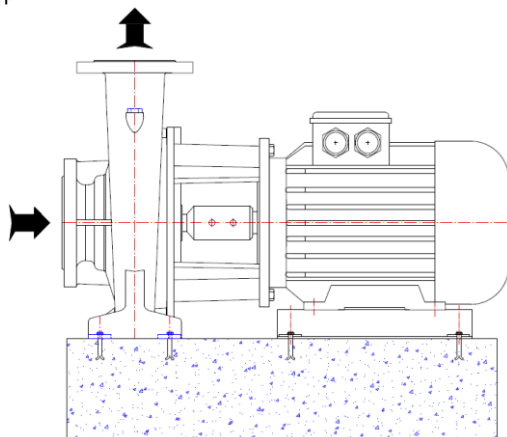

Figure 3: A typical Concrete Foundation



After the pump has been fixed, mount the guard. According to the accident prevention regulations, all preventions and protective devices related to rotating parts shall be in their intended place and in operational form.

6.3. Piping

6.3.1. General



- Do not use the pump as the hinged support for the piping system.
- Put enough supports under the piping system in order to carry the weight of the pipe and fittings.
- Avoid piping system loads on pump by installing flexible components (compensator) to suction and discharge of the pump.
- By mounting flexible supporting items, take into consideration the fact that these items may elongate under the pressure.
- Suction pipe shall be in a constantly increasing slope to the pump. Air in the suction pipe shall be arranged to move into the pump
- Discharge piping shall be in a constantly increasing slope to the reservoir or discharge point, without up and downs which can cause air pockets in the piping system. At locations where forming of air pockets is possible, special items like air valve and air cock are mounted to evacuate the trapped air.
- It is important that pipe diameter and fittings are at least as much as the pump opening diameter or preferable one or two size higher. One should never use fittings with smaller diameters than the pump exit diameter. In particular, preferred fittings like foot valve, strainer, filter, check valves and valves shall have large free passing area, and low friction loss coefficient.
- For piping systems with hot liquids, thermal expansions are to be taken into account and compensators shall be mounted in accordance with these expansions. Caution shall be exercised to avoid the loading of pump in this installation.

6.3.2. Specification of Work in Piping Installation



In installation of pipes, follow the procedures below certainly.

- Install the pump on the concrete base as illustrated in Figure 3.
- Take out the guards (placed by the manufacturer) from suction and discharge openings of the pump.
- Close the suction and discharge flanges with rubber gaskets. This precaution is important to avoid the undesired substances (weld crust, weld slag, sand, stone, wood piece etc.) get into the pump. Do not take off this gasket until the installation is completed.
- Start the installation of piping from the pump side. Do the necessary assembling and welding of the parts in a successive order.
- In these operations, do not neglect to put the necessary supports in their respected locations.
- Following above procedure, complete all piping system at suction side up to the suction tank (or foot valve if available), at discharge side up to do discharge collector and discharge pipe.
- When all installation and welding process is done and the heat dissipated by welding is removed, dismantle all the bolted connections from the suction tank to discharge pipe. Take out all demountable parts.
- Clean these parts and then paint body coat completely inside and outside.
- Mount the parts again in their intended places. However, this time start from the discharge line and move downward to the pump. In this instance, do not forget to check the flange gaskets. If needed, (for example deformation during welding) replace them.
- Concerning the connection of the pump flanges to piping, in case of misalignment of axis and flange holes, do not force the system to eliminate the misalignment. Forcing the system may cause difficult-to-correct problems.
- If there is an axial misalignment between the flanges of the pump and the pipe, due to the welding or any other reasons, cut the pipe from a suitable location in order to fix the problem. Connect the pipe (pump side) to the pump. After carrying out the necessary correction, connect the parts again by welding..
- Dismantle and clean the last welded part. Repaint again and mount on its place.

- After all these processes are accomplished, remove the rubber gasket from the suction and discharge openings. Open their holes and mount them again on their intended place.

- Three phased-motor shall be connected to power supply.
- Wait the motor to cool down when thermic protected motor breaks in circuit due to the overheating. Make sure the motor does not start automatically until it cools completely
- In order to protect the motor from overcharging and short circuit use a thermic or thermic-magnetic relay. Adjust this relay to the nominal current of the motor.

6.3.3. Specification of Work after Installation of Piping and Piping System

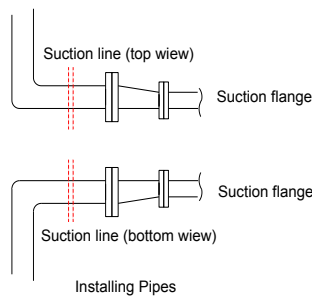

Figure 4: Piping System

An illustrative piping system is shown in Figure 20. Appropriate manometers shall be mounted on suction and discharge pipe lines.



Complete the auxiliary pipe connections in piping system if exist (cooling to bearing housing, and stuffing box (seal), relief pipe, oil pipe etc.)

6.4. Motor Connection

Motor shall be connected by an electrical technician according to the connection (switch) diagram. Local electricity policies regulations have to be applied.



- Electrical connections have to be made by authorized electricians.
- In dismantling the pump, make sure the electricity is cut off before taking the motor cover out.
- Use the appropriate electrical connection to the motor.

6.4.1. Motor Connection Diagram

Motors requiring high moments at start up shall not be connected star-delta
Frequency controlled motors, require high moment at start up and have to be cooled properly at low speeds. Provide the necessary cooling for the motors.

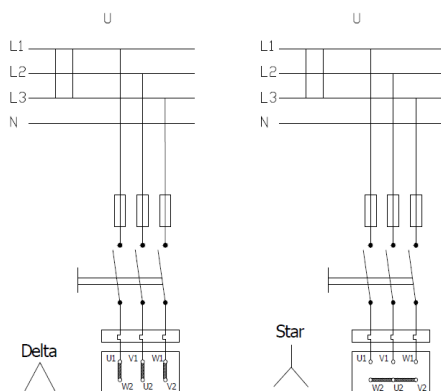

Figure 5: Electric Connection Diagram

Electrical circuit	Motor	
U (Volt)	230/400 V	400 V
3 x 230 V	Delta	-
3 x 400 V	Star	Delta

6.4.2. Motor Protection



Electrical equipments, terminals and the components of the control systems may carry electric current even though they are not operating. They may cause deadly and serious injuries or irreparable material damages.

7. COMMISSIONING, START UP AND OPERATING

7.1. Preparations Before Start Up

- Check mechanical seals of pump.
- Make sure that the pump and the suction pipe is completely filled with water before the starting. If the pump operates on a positive suction head, no problem will be encountered. Suction valve is opened and air drains are un-tightened.
- Pumps with foot valve are filled with water by opening the pump filling tap or, one takes advantage of the water accumulated in the discharge pipe and by using a small valve the check valve is bypassed and the pump is filled.
- In vacuum pump driven pumps, by operating the vacuum pump one achieves to fill the pump via increasing the water level in the suction pipe.



Do not start your pump dry (WITHOUT WATER).

7.2. Checking The Direction of Rotation



- The direction of rotation is indicated on the pump label with an arrow. Apart from special cases, it is clockwise direction when looking from the motor end. Observe if the pump is rotating in the expected sense by starting the motor for a very short instant. If it is turning in the opposite sense, interchange any of two motor leads.
- If the motor connection is delta, open the discharge valve slowly.
- If the motor connection is star-delta, set the time relay to maximum 5 seconds. Monitor the passage from star to delta by pressing the start button. As soon as you are assured that the connection is delta, open the discharge valve slowly. Continue opening the valve until you read the amperage on the electrical panel
- **One should always check the labels which show the direction of rotation and the direction of fluid flow. If you dismantle the coupling protection to monitor the direction of rotation, do not restart the engine before remounting the protection.**



As a result of getting in touch with rotating and stable parts each other temperature increase can occur. Never check the direction of rotation while the pump is dry.

7.3. Start up Procedure

- Check if the suction valve is open and the discharge valve is closed. Start the motor
- Wait until the motor reaches sufficient speed. (In Star-delta connections, wait until the engine passes to delta connection.)
- Keeping an eye on the amperage shown on the panel, open the discharge valve slowly.
- In the primary operation, if the discharge pipe is empty, do not open the valve completely. By keeping an eye on the amperage, open the valve

with care regarding that it should not exceed the value indicated on pump's label.

- After opening the valve completely, check the pressure from the pump exit manometer and make sure that this value is the pump operating pressure value and is indicated on pump's label.
- If the value one reads is less than the pump label value when the valve is completely open, it means that the height is miscalculated. Increase the value by narrowing the valve and bring it to pump's label value.
- If the value one reads is greater than the pump label value when the valve is completely open, it means that the height is calculated less than what it should be in reality. The device is pumping less than what is requested. Check the installation and the calculations.
- **Minimum flow rate:** If the pump is working with zero flow rates (closed valve) from time to time during its operation, the water inside the pump may endanger the pump by getting warmed up. In such cases, a minimum flow valve must be connected to the pump exit.



Stop the motor if the pump gets too hot. Wait until it gets cold. Then start the system up again carefully.

7.4. Shut Down Procedure



During sudden start ups and stops, a pressure reducing valve must be placed at the exit section of high flow rate pumps whose discharge pipelines are long, in order to reduce water hammer effect. Water hammer may explode the pump.

In normal conditions (apart from sudden power shut down, etc), stop the pump as below:

- Close the discharge valve slowly
- Switch the power off, stop the motor. Notice that the rotor slows down.
- Do not start up the motor at least before 1 to 2 minutes.
- If the pump will be out of use for a long time, close the suction valve and auxiliary circuits. If the pump is outside and if there exists a danger of frost, remove all drain taps and empty all the water inside the pump. (5.2. Storage)



If the pump is outside and if there exists a danger of frost, remove all drain taps and empty all the water inside the pump.

8. MAINTENANCE



Maintenance operations must be done by authorized personnel with protective clothing only. The personnel must also beware of high temperatures and harmful and/or caustic liquids. Make sure that the personnel read carefully the manual.

- The instructions in Safety Precautions must be executed during maintenance and repair
- Continuous monitoring and maintenance will increase the engine's and pump's lives.

The instructions below should be applied.

8.1. The Checks During the Operation

- Pump must never be operated without water.
- Pump must not be operated for a long time with the discharge valve closed (zero capacity).
- Precautions must be taken against flare up when the component temperatures are over 60°C. "Hot Surface" warnings must be placed over necessary areas.
- All the auxiliary systems must be in use while the pump is operating.

- If the pump has mechanical sealing, there is no need for excessive maintenance. Water leakage from the mechanical sealing indicates the fact that the sealing is worn out and therefore needs to be replaced.
- If the system consists of a substitute pump, keep it ready by operating it once a week. Check also the auxiliary systems of the substitute pump.



The air of the pump and suction line must be drained before commissioning of the pump. The interior of the pump contacting with pumped liquid including gasket way and auxiliary systems must be filled with pumped liquid.

- Ensure that delivery pressure is enough.
- Do not operate the pump at values above pressure, temperature or motor speed values specified by manufacturer, never use improper liquids with the pump.

8.1.1. Component Check



To make possible the visual control, one must be able to reach the pump from any direction. Especially, to be able to dismount the internal units of the pump and the engine, sufficient free space must be created around them for maintenance and repair. Furthermore, one must make sure that the piping system can easily be dismounted.

8.1.2. Bearing and Lubrication

Rolling bearings are not used in NMM type pumps. Motor bearing is enough for countervailing all axial and radial forces. Motor bearings are provided with lifelong heat resistant grease.

8.1.3. Mechanical Seals

Mechanical seals are used at NMM type pumps. Mechanical seals are absolutely leak tight and needs less maintenance than soft packing.

Mechanical seal;

1. Provides leak proof operation in heavy operating conditions (in waste water pumps, chemical process and refinery pumps).
2. Easily mountable and needs less maintenance.
3. Does not cause wearing on the shaft
4. Sealing operation does not depend on the quality of shaft finishing.

8.1.4. Drive

Apply to the operating instructions of the motor manufacturer.

8.1.5. Auxiliary Components

Check regularly the fittings and the gaskets, replace the worn out pieces.

8.2. Service

Our Customer Service Department offers after-sale service. Manager should employ authorized and trained personnel for mounting/dismounting procedures. Before these procedures, one must make sure that pump interior is clean and empty.

This criterion is also valid for the pumps which are sent to our factory or to our service points.



Maintain the safety of the personnel and the environment in every field procedure.

8.3. Spare Parts

The spare parts of NM type pumps are guaranteed for **10 YEARS** by **MAS DAF MAKINA SANAYI A.Ş.**

In your spare parts requests, please indicate the below listed values that are indicated on your pump's label.

- Pump type and size:**
- Motor power and speed:**
- Pump serial number:**
- Capacity and head:**

If you wish to keep spare parts in store, depending on the number of same type of pumps, for two operation years, the quantities which are listed in the table below are recommended.

Component Name	The Number of Equivalent Pumps in the Installation						
	1-2	3	4	5	6-7	8-9	10+
Shaft (key included) (quantity)	1	1	2	2	2	3	%30
Impeller (quantity)	1	1	1	2	2	3	%30
Mechanical Seal	1	2	2	3	3	4	%50
Wear Ring	1	1	1	2	2	3	%50

Table 1: Spare Part List

9. NOISE LEVEL AND VIBRATION

The reasons which increase the noise level are indicated below:

- Touch of coupling halves due to worn rubber sleeves (incorrectly aligned)
- Noise level increases due to the fact that the pump is not founded properly (Vibration)
- If the installation does not have compensator noise and vibration increases.
- Wearing in ball bearing also increases noise level.



Check if there is any noise increasing elements in your installation.

9.1. Expected Noise Values

Measurement conditions:

- The distance between the measure point and the pump : 1m
- Operation : Without Cavitation
- Motor : IEC Standard Motor
- Tolerance : ±3 dB

Power of Motor PN [kW]	Sound Pressure Level (dB) *	
	Pump with Motor	
	1450 rpm/min	2900 rpm/min
0,25	53,0	-
0,37	54,0	-
0,55	55,0	-
0,75	56,0	66,0
1,1	57,0	66,0
1,5	58,0	67,0
2,2	59,0	67,0
3,0	60,0	68,0
4,0	61,0	68,0
5,5	62,0	70,0
7,5	64,0	71,0
11,0	65,0	73,0
15,0	67,0	74,0
18,5	68,0	75,0
22,0	69,0	76,0
30,0	70,0	77,0
37,0	71,0	78,0

Table 2: Sound Pressure Level

(*) Without protective sound hood, measured at a distance of 1 m directly above the driven pump, in a free space above a sound reflecting surface.

The above values are maximum values. The surface noise pressure level at dB(A) unit is shown as (L_{PA}). This complies with TS EN ISO 20361.

10. DISASSEMBLY, REPAIR AND REASSEMBLY



Before starting work on the pump set, make sure it is disconnected from the mains and can not be switched on accidentally.

Follow the safety precautions outlined in "Safety instructions".

10.1. Disassembly

- Close all valves in the suction and discharge lines, drain the pump.
- Remove guard.
- Thanks to "Back Pull Out Design"; the impeller, shaft and other rotating parts being removable no need to disconnect the suction and delivery pipes.
- If to take out the complete pump is necessary, disconnect pump from the driver, suction and discharge pipes and detach the base plate.
- Dismantle the rotor group with motor from the volute casing (Be careful to keep the stuffing box cover in place to avoid any mechanical seal trouble).
- Unscrew the impeller end nut (65) and take out the impeller (20) and impeller key (210). Use rust remover solvent during dismantling if necessary.
- Take out the set screws on the pump shaft. Take off the motor by unscrew the hex bolts (320)
- Pull out the rotating part of the mechanical seal (250).
- Take out the shaft.

10.2. Reassembly

- Reassembly proceeds in reverse sequence to disassembly as described in section 10.1. You may find the attached drawings useful.
- Coat the seats and screw connections with graphite, silicon or similar slippery substance before reassembly. If you can not find any of the above you may use oil instead (except the pumps for drinking water).
- Never use the old gaskets, make sure the new gaskets and o-rings are the same size as the old ones.
- Slip the pump shaft (60) onto the motor shaft, fix the set screws.
- Place the stationary part of mechanical seal to its place on the adaptor (12)
- Mount the adaptor to the motor flange.
- Place the impeller key (210) into keyway, slide the impeller (20) onto the shaft (61) and screw the impeller nuts (65).
- Now reassembly of the rotor group is completed.
- Finally mount rotor assembly to the volute casing. (In the repair shop or on site.)
- Make sure the gaskets and o-rings are evenly placed without sliding and not damaged or not squeezed at all.
- Place the pump on the baseplate, couple the motor. Connect suction and discharge pipes as well as auxiliary pipes. Take the unit into operation as it was indicated in section 7.
- Put the stationary part of mechanical seal in its place on the seal cover (58-59). Then put this part on the shaft. Afterwards put the rotating part of mechanical seal on its position.
- Mount stuffing box (03) to bearing housing (30).
- At this stage you can insert the irrigation ring.
- Replace impeller key and pump impellers. Tighten the impeller nuts.
- Replace the coupling and coupling key.
- Tighten mechanical seal cover.
- Now reassembly of the rotor group is completed.
- Finally mount rotor assembly to the volute casing. (In the repair shop or on site.)

11. POSSIBLE FAILURES, CAUSES, SOLUTIONS

Possible failures and solution strategies are listed in the table below. Please apply to the Customers' Service Department of our company when a generic solution is not found to your problem.



While the failures are repaired the pump must always be dry and un-pressurized.

POSSIBLE FAILURE	CAUSES	SOLUTIONS
The pump delivers insufficient capacity	<ul style="list-style-type: none"> Discharge head too high Very high counter pressure Pump and/or pipe cannot discharge air, cannot suck Occurrence of air pockets inside the pipe NPSH is too low 	<ul style="list-style-type: none"> Readjust the operating point See if there is any undesired material inside the pipe Vent completely the pump and the pipe Change the piping configuration Increase the liquid level
Motor overload	<ul style="list-style-type: none"> System pressure is lower than the requested pressure level Speed too high Liquid pumped of different specific gravity and viscosity than that for which pump is rated Engine works at two phases 	<ul style="list-style-type: none"> Adjust the operating pressure to the label value Decrease the speed Increase the engine power Replace the fuse and control the electrical connections
Pump head is too high	<ul style="list-style-type: none"> System pressure is higher than the requested pressure level 	<ul style="list-style-type: none"> Set the operating pressure to the label value.
Bearing temperatures are high	<ul style="list-style-type: none"> Too much, too little or improper lubrication Increase in axial forcing 	<ul style="list-style-type: none"> Change the oil, decrease or increase its quantity Clean the balance holes on the impeller disc
Excessive leakage from the stuffing box	<ul style="list-style-type: none"> Worn out gland 	<ul style="list-style-type: none"> Use brand new gland Change the stuffing bush
Noisy operation	<ul style="list-style-type: none"> Worn out motor or pump ball bearings Cavitation Operation in the far left or right of the performance curve 	<ul style="list-style-type: none"> Replace Close the delivery partially in order to reduce the capacity. Operate the pump at its label setting
Excessive increase in pump temperature	<ul style="list-style-type: none"> Pump and/or pipe can neither discharge, nor aspirate air Too low capacity 	<ul style="list-style-type: none"> Bleed completely the pump and the pipe Open more the valve
Vibration	<ul style="list-style-type: none"> Pump and/or pipe can neither discharge, nor aspirate air NPSH is too low Internal components of the pump are worn out System pressure is lower than the requested pressure level Too much, too little or improper lubrication Rotor unbalanced Improper bearings 	<ul style="list-style-type: none"> Bleed completely the pump and the pipe Increase the liquid level Replace the worn out components Adjust the operating pressure to the label value In case of continuous overload, decrease the impeller diameter Change the oil, decrease or increase its quantity Balance the impeller again Use new bearings

Table 3: Possible Failures, Causes, Solutions

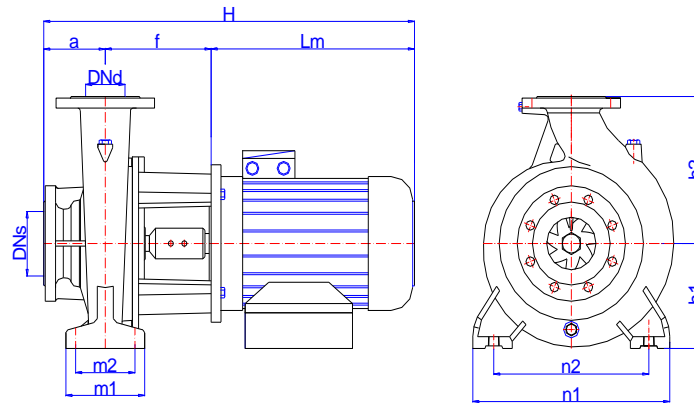
12. PUMP DIMENSIONS TABLE

Figure 6: NMM Pump Dimensions Figure

		MOTOR		FLANGES		GENEL	PUMP									Mechanical Seal	
		KW	IEC	Lm	DNd	DNs	L	a	f	h1	h2	n1	n2	m1	m2	s	Nominal Impeller Diameter
				mm													
32-160	1450 rpm	0.25	71	222.5	32	50	461.5	80	159	132	160	240	190	100	70	12	20
		0.37	71	222.5			461.5		159								
		0.55	80	243.5			482.5		159								
		0.75	80	243.5			482.5		159								
	2900 rpm	1.5	90L	266.5	32	50	506.5	80	160	132	160	240	190	100	70	12	20
		2.2	90L	266.5			506.5		160								
		3	100L	292			552		180								
		4	112M	335.5			595.5		180								
		5.5	132S	360.5			640.5		200								30
	32-200	1450 rpm	0.37	71	222.5	32	50	462.5	80	160	160	180	240	190	100	70	12
0.55			80	243.5	483.5			160									
0.75			80	243.5	483.5			160									
1.1			90L	266.5	506.5			160									
1.5			90L	266.5	506.5			160									
2900 rpm		4	112M	335.5	32	50	595.5	80	180	160	180	240	190	100	70	12	20
		5.5	132S	360.5			645.5		205								30
		7.5	132M	395.5			680.5		205								
		11	160M	666			976		230								
		32-250	1450 rpm	0.55			80		243.5								32
0.75	80			243.5	513.5	170											
1.1	90L			266.5	536.5	170											
1.5	90L			266.5	536.5	170											
2.2	100L			292	582	190											
2900 rpm	5.5		132S	360.5	32	50	675.5	100	215	180	225	320	250	125	95	12	30
	7.5		132M	395.5			710.5		215								
	11		160M	666			1006		240								
	15		160L	666			1006		240								
	18.5		160L	666			1006		240								
40-160	1450 rpm	0.25	71	222.5	40	65	462.5	80	160	132	160	240	190	100	70	12	20
		0.37	71	222.5			462.5		160								
		0.55	80	243.5			483.5		160								
		0.75	80	243.5			483.5		160								
	2900 rpm	3	100L	292	40	65	552	80	180	132	160	240	190	100	70	12	20
		4	112M	335.5			595.5		180								30
		5.5	132S	360.5			640.5		200								
		7.5	132M	395.5			675.5		200								

		MOTOR			FLANGES		GENEL	PUMP								Mechanical Seal													
		KW	IEC	Lm	DNd	DNs	L	a	f	h1	h2	n1	n2	m1	m2	s	Nominal Impeller Diameter												
				mm			mm											mm	mm	mm	mm	mm	mm						
40-200	1450 rpm	0.55	80	243.5	40	65	503.5	100	160	160	180	265	212	100	70	12	20												
		0.75	80	243.5			503.5		160																				
		1.1	90L	266.5			526.5		160																				
		1.5	90L	266.5			526.5		160																				
	2900 rpm	5.5	132S	360.5	40	65	665.5	100	205	160	180	265	212	100	70	12	30												
		7.5	132M	395.5			700.5		205																				
		11	160M	666			996		230																				
		15	160L	666			996		230																				
40-250	1450 rpm	1.5	90L	266.5	40	65	526.5	100	160	180	225	320	250	125	95	12	20												
		2.2	100L	292			572		180																				
		3	100L	292			572		180																				
	2900 rpm	7.5	132M	395.5	40	65	725.5	100	230	180	225	320	250	125	95	12	30												
		11	160M	666			996		230																				
		15	160L	666			996		230																				
		18.5	160L	666			996		230																				
		22	180M	519			849		230																				
		30	200L	555			885		230																				
		50-160	1450 rpm	0.75			80		243.5									50	65	503.5	100	160	160	180	265	212	100	70	12
1.1	90L			266.5	526.5	160																							
1.5	90L			266.5	526.5	160																							
2900 rpm	4		112M	335.5	50	65	615.5	100	180	160	180	265	212	100	70	12	20												
	5.5		132S	360.5			660.5		200																				
	7.5		132M	395.5			695.5		200																				
	11		160M	666			966		200																				
50-200	1450 rpm	1.1	90L	266.5	50	65	526.5	100	160	160	200	265	212	100	70	12	20												
		1.5	90L	266.5			526.5		160																				
		2.2	100L	292			572		180																				
	2900 rpm	7.5	132M	395.5	50	65	700.5	100	205	160	200	265	212	100	70	12	30												
		11	160M	666			996		230																				
		15	160L	666			996		230																				
		18.5	160L	666			996		230																				
50-250	1450 rpm	2.2	100L	292	50	65	572	100	180	180	225	320	250	125	95	12	20												
		3	100L	292			572		180																				
		4	112M	335.5			615.5		180																				
		5.5	132M	395.5			700.5		205																				
	2900 rpm	15	160L	666	50	65	996	100	230	180	225	320	250	125	95	12	30												
		18.5	160L	666			996		230																				
		22	180M	519			849		230																				
		30	200L	555			885		230																				
		37	200L	555			885		230																				
		45	225M	625			955		230																				
		50-315	1450 rpm	4			112M		335.5								50	80	625.5	100	190	225	280	360	280	160	120	12	30
				5.5			132M		395.5										710.5		215								
7.5	132M			395.5	710.5	215																							
11	160M			666	1006	240																							
15	160L			666	1006	240																							

		MOTOR			FLANGES		GENEL	PUMP								Mechanical Seal													
		KW	IEC	Lm	DNd	DNs	L	a	f	h1	h2	n1	n2	m1	m2	s	Nominal Impeller Diameter												
				mm			mm											mm	mm	mm	mm	mm	mm						
65-160	1450 rpm	0.75	80	243.5	65	80	503.5	100	160	160	200	280	212	125	95	12	20												
		1.1	90L	266.5			526.5		160																				
		1.5	90L	266.5			526.5		160																				
		2.2	100L	292			572		180																				
	2900 rpm	5.5	132M	395.5	65	80	695.5	100	200	160	200	280	212	125	95	12	30												
		7.5	132M	395.5			695.5		200																				
		11	160M	666			996		230																				
		15	160L	666			996		230																				
		18.5	160L	666			996		230																				
65-200	1450 rpm	2.2	100L	292	65	80	572	100	180	180	225	320	250	125	95	12	20												
		3	100L	292			572		180																				
		4	112M	335.5			615.5		180																				
	2900 rpm	18.5	160L	666	65	80	996	100	230	180	225	320	250	125	95	12	30												
		22	180M	519			849		230																				
		30	200L	555			915		260																				
		37	200L	555			915		260																				
																												35	
65-250	1450 rpm	3	100L	292	65	80	582	100	190	200	250	360	280	160	120	16	20												
		4	112M	335.5			625.5		190																				
		5.5	132M	395.5			710.5		215																				
		7.5	132M	395.5			710.5		215																				
	2900 rpm	22	180M	519	65	80	859	100	240	200	250	360	280	160	120	16	30												
		30	200L	555			925		270																				
		37	200L	555			925		270																				
		45	225M	625			995		270																				
																												35	
65-315	1450 rpm	5.5	132M	395.5	65	80	735.5	125	215	224	280	400	315	160	120	16	30												
		7.5	132M	395.5			735.5		215																				
		11	160M	666			1031		240																				
		15	160L	666			1031		240																				
65-400	1450 rpm	11	160M	666	65	100	1031	125	240	250	355	400	315	160	120	16	30												
		15	160L	666			1031		240																				
		18.5	180M	519			884		240																				
		22	180L	519			884		240																				
	30	200L	555	950	270																								
																	35												
80-160	1450 rpm	1.1	90L	266.5	80	100	551.5	125	160	180	225	320	250	125	95	12	20												
		1.5	90L	266.5			551.5		160																				
		2.2	100L	292			597		180																				
		3	100L	292			597		180																				
	2900 rpm	7.5	132M	395.5	80	100	720.5	125	200	180	225	320	250	125	95	12	30												
		11	160M	666			1021		230																				
		15	160L	666			1021		230																				
		18.5	160L	666			1021		230																				
		22	180M	519			874		230																				
80-200	1450 rpm	2.2	100L	292	80	100	607	125	190	180	250	345	280	125	95	12	30												
		3	100L	292			607		190																				
		4	112M	335.5			650.5		190																				
		5.5	132M	395.5			735.5		215																				
		7.5	132M	395.5			735.5		215																				
	2900 rpm	22	180M	519	80	100	884	125	240	180	250	345	280	125	95	12	30												
		30	200L	555			950		270																				
		37	200L	555			950		270																				
		45	225M	625			1020		270																				
																												35	

		MOTOR			FLANGES		GENEL	PUMP								Mechanical Seal	
		KW	IEC	Lm	DNd	DNs	L	a	f	h1	h2	n1	n2	m1	m2	s	Nominal Impeller Diameter
				mm			mm	mm	mm	mm	mm	mm	mm	mm	mm	mm	
80-250	1450 rpm	5.5	132M	395.5	80	100	735.5	125	215	200	280	400	315	160	120	16	30
		7.5	132M	395.5			735.5		215								
		11	160M	666			1031		240								
		15	160L	666			1031		240								
80-315	1450 rpm	11	160M	666	80	100	1031	125	240	250	315	400	315	160	120	16	30
		15	160L	666			1031		240								
		18.5	180M	519			884		240								
		22	180L	519			884		240								
80-400	1450 rpm	18.5	180M	519	80	100	894	125	250	280	355	500	400	200	150	20	45
		22	180L	519			894		250								
		30	200L	555			960		280								
		37	225M	625			1030		280								
		45	225M	625			1030		280								
100-160	1450 rpm	1.1	90L	266.5	100	125	551.5	125	160	200	280	360	280	160	120	16	20
		1.5	90L	266.5			551.5		160								
		2.2	100L	292			597		180								
		3	100L	292			597		180								
		4	112M	335.5			640.5		180								
	2900 rpm	11	160M	666	100	125	1021	125	230	200	280	360	280	160	120	16	30
		15	160L	666			1021		230								
		22	180M	519			874		230								
		30	200L	555			940		260								
37	200L	555	940	260	35												
100-200	1450 rpm	3	100L	292	100	125	607	125	190	200	280	360	280	160	120	16	30
		4	112M	335.5			650.5		190								
		5.5	132M	395.5			760.5		240								
		7.5	132M	395.5			760.5		240								
	2900 rpm	22	180M	519	100	125	884	125	240	200	280	360	280	160	120	16	35
		30	200L	555			950		270								
		37	200L	555			950		270								
		45	225M	625			1020		270								
100-250	1450 rpm	5.5	132M	395.5	100	125	735.5	125	215	225	280	400	315	160	120	16	30
		7.5	132M	395.5			735.5		215								
		11	160M	666			1031		240								
		15	160L	666			1031		240								
		18.5	180M	519			884		240								
100-315	1450 rpm	15	160L	666	100	125	1046	140	240	250	315	400	315	160	120	16	30
		18.5	180M	519			899		240								
		22	180L	519			899		240								
		30	200L	555			965		270								
		37	225M	625			1035		270								35
100-400	1450 rpm	22	180L	519	100	125	909	140	250	280	355	500	400	200	150	20	45
		30	200L	555			975		280								
		37	225M	625			1095		330								
		45	225M	625			1095		330								
		55	250M	746			1216		330								
125-200	1450 rpm	5.5	132M	395.5	125	150	750.5	140	215	250	315	400	315	160	120	16	30
		7.5	132M	395.5			750.5		215								
		11	160M	666			1046		240								
		15	160L	666			1046		240								

		MOTOR			FLANGES		GENEL	PUMP									Mechanical Seal
		KW	IEC	Lm	DNd	DNs	L	a	f	h1	h2	n1	n2	m1	m2	s	Nominal Impeller Diameter
				mm	mm	mm	mm	mm	mm	mm	mm	mm	mm	mm	mm	mm	
125-250	1450 rpm	11	160M	666	125	150	1056	140	250	250	355	400	315	160	120	16	30
		15	160L	666			1056		250								
		18.5	180M	519			909		250								
		22	180L	519			909		250								
		30	200L	555			975		280								35
125-315	1450 rpm	18.5	180M	519	125	150	914	140	255	280	355	500	400	200	150	20	35
		22	180L	519			914		255								
		30	200L	555			980		285								
		37	225M	625			1080		315								
125-400	1450 rpm	37	225M	625	125	150	1095	140	330	315	400	500	400	200	150	20	45
		45	225M	625			1095		330								
		55	250M	746			1216		330								
		75	280S	767			1237		330								
		90	280M	818			1288		330								

Table 4: NMM Pump Dimensions Table
13. TIGHTENING TORQUES

THREAD DIAMETER	TIGHTENING TORQUE MAX (Nm)	
	Property Classes	
	8.8	10.9
M4	3.0	4.4
M5	5.9	8.7
M6	10	15
M8	25	36
M10	49	72
M12	85	125
M14	135	200
M16	210	310
M18	300	430
M20	425	610
M22	580	820
M24	730	1050
M27	1100	1550
M30	1450	2100
M33	1970	2770
M36	2530	3560

Table 5: Tightening Torques Table

14. FORCES AND MOMENTS AT THE PUMP FLANGES

All of the applied load if not reached the maximum allowable value, to provide that the following additional conditions, one of these loads may exceed the normal limit:

- Any component of a force or a moment, must be limited 1.4 times of the maximum allowable value,
- The actual force and moments acting on each flange, should provide the following formula:

$$\left(\frac{\sum |F|_{\text{actual}}}{\sum |F|_{\text{maximum allowable}}} \right)^2 + \left(\frac{\sum |M|_{\text{actual}}}{\sum |M|_{\text{maximum allowable}}} \right)^2 \leq 2$$

In here, $\sum |F|$ and $\sum |M|$ are arithmetic sum of the loads for each flange at the pump level, without regard of the algebraic signs of the actual and maximum allowable values.

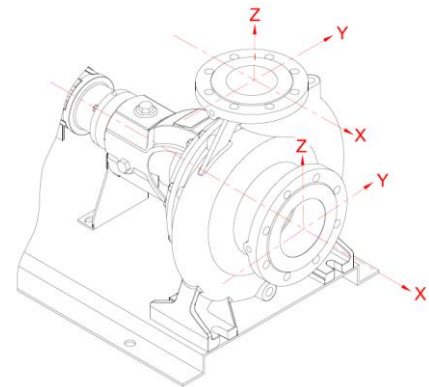

PUMP TYPE	FORCES								MOMENTS					
	DN FLANGE		SUCTION FLANGE			DISCHARGE FLANGE			SUCTION FLANGE			DISCHARGE FLANGE		
	SS	DS	N			N			Nm			Nm		
			F _y	F _z	F _x	F _y	F _z	F _x	M _y	M _z	M _x	M _y	M _z	M _x
NMM 32-160	50	32	500	450	550	283	350	300	333	383	467	250	283	367
NMM 32-200														
NMM 32-250														
NMM 40-160	65	40	617	567	700	333	417	367	367	400	500	300	350	433
NMM 40-200														
NMM 40-250														
NMM 50-160	65	50	617	567	700	450	550	500	367	400	500	333	383	467
NMM 50-200														
NMM 50-250														
NMM 50-315	80	65	750	683	833	567	700	617	383	433	533	367	400	500
NMM 65-160														
NMM 65-200														
NMM 65-250	100	80	1000	900	1117	683	833	750	383	433	533	383	433	533
NMM 65-315														
NMM 65-400														
NMM 80-160	125	100	1183	1067	1317	900	1117	1000	417	483	583	417	483	583
NMM 80-200														
NMM 80-250														
NMM 80-315	150	125	1500	1350	1667	1067	1317	1183	500	633	700	500	633	700
NMM 80-400														
NMM 100-200														
NMM 100-250	150	125	1500	1350	1667	1067	1317	1183	500	633	700	500	633	700
NMM 100-315														
NMM 100-400														
NMM 125-200	150	125	1500	1350	1667	1067	1317	1183	500	633	700	500	633	700
NMM 125-250														
NMM 125-315														
NMM 125-400	150	125	1500	1350	1667	1067	1317	1183	500	633	700	500	633	700
NMM 125-250														
NMM 125-315														
NMM 125-400														

Table 6: Forces and Moments at The Pump Flanges

Forces at the pump flanges were calculated according to TS EN ISO 5199 standard. The calculations are valid for the materials of cast iron and bronze. Forces and moments at the flanges that made of stainless material will be approximately twice as moments in the table.

15. SAMPLE PLUMBING

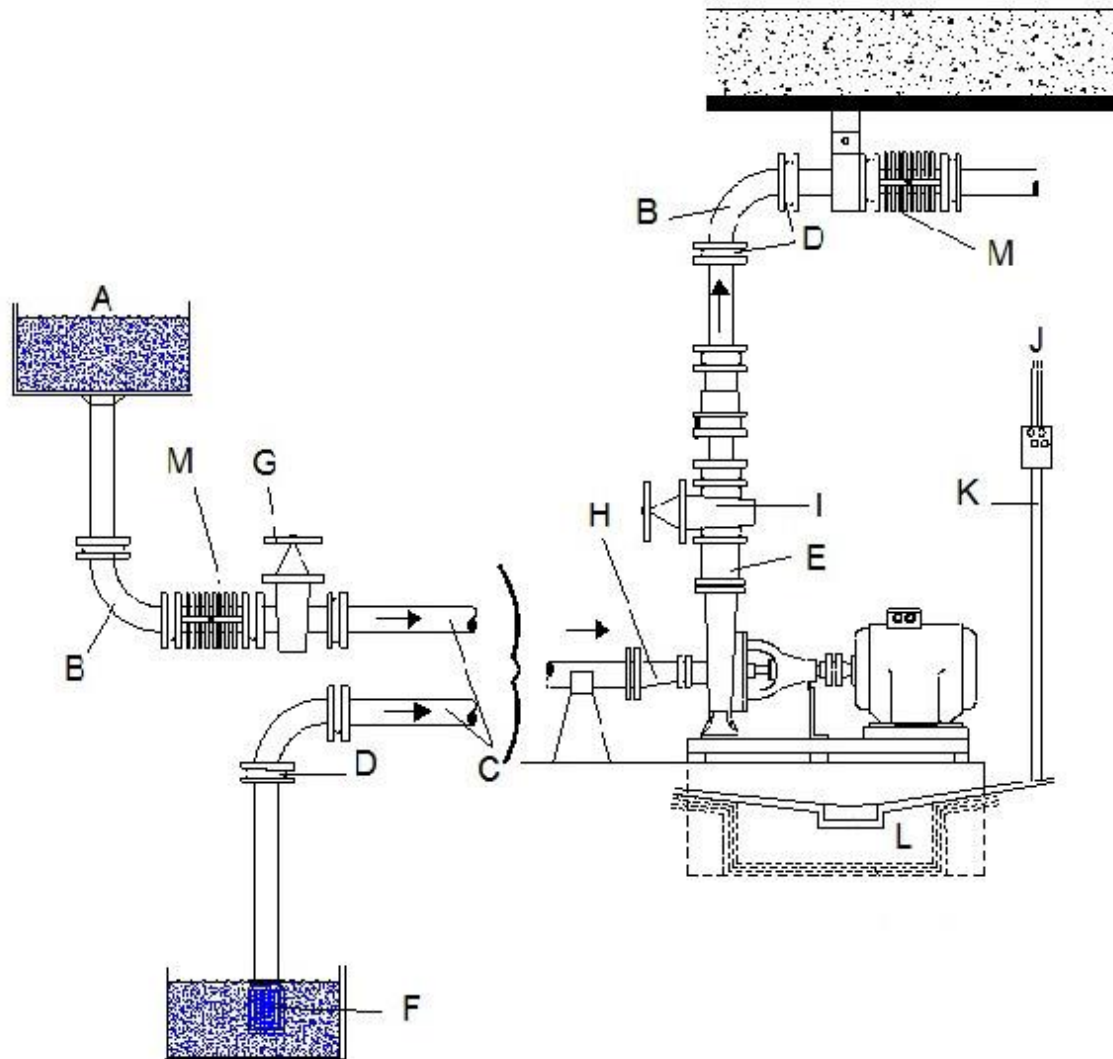
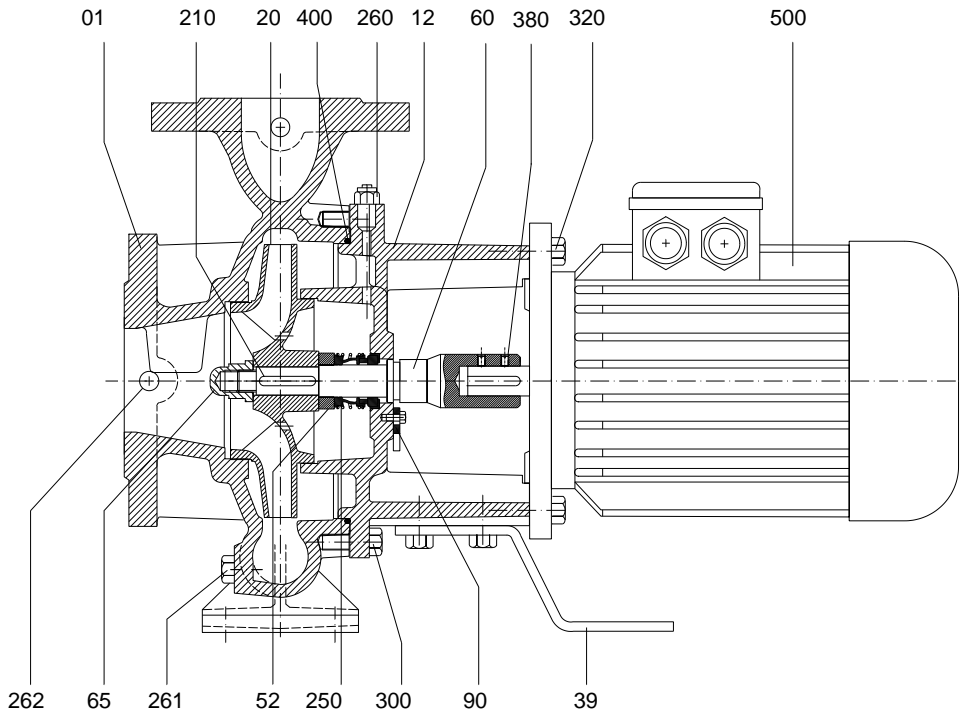

Figure 7: Sample Plumbing

- A. Tank
- B. Long radius elbow
- C. Minimum slope is 2 cm/m
- D. Fittings, flanges etc.
- E. Non-return valve
- F. Foot valve
- G. Suction valve
- H. Reducer
- I. Discharge valve
- J. Electrical connection
- K. Insulated cable
- L. Concrete foundation
- M. Compensator

16. NMM SECTIONAL DRAWING AND PARTS LIST (WITHOUT COUPLING)



Note: This system is used for 5.5 kW or less motor power.

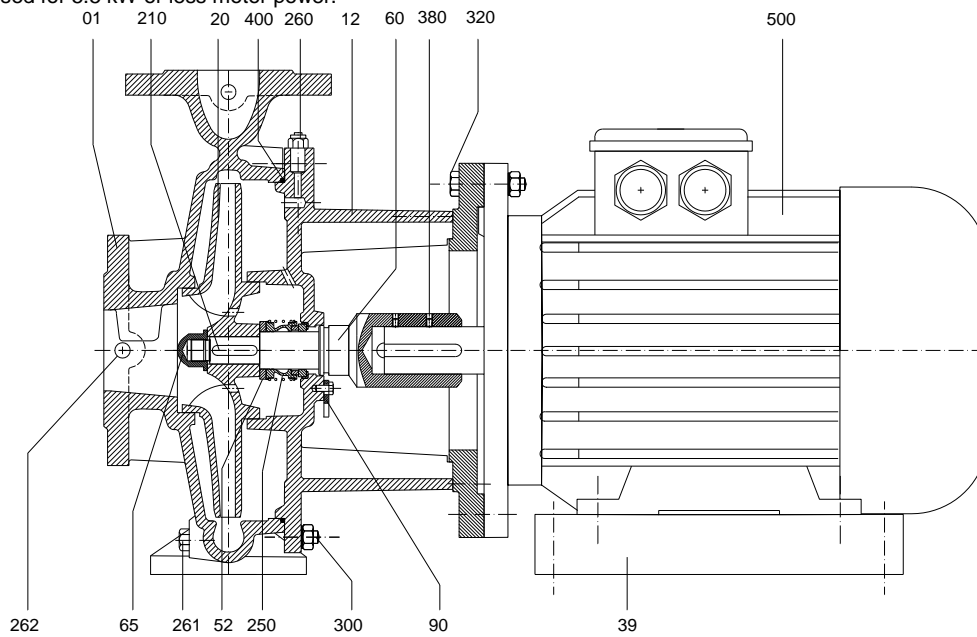

Note: This system is used for motor power above 5.5 kW.

Figure 8: NMM Sectional Drawing (Without Coupling)

PART NO	PART NAME	PART NO	PART NAME
01	Pump Casing	250	Mechanical Seal
12	Adapter	260	Plug
20	Impeller	261	Drain Plug
39	Supporting Foot	262	Plug (Casing)
52	Mechanical Seal Sleeve	300	Stud, Casing
60	Pump Shaft	320	Hexagonal Bolt
65	Impeller Nut	380	Setscrew
90	Shaft Fixing Device	400	O-Ring
210	Impeller Key	500	Motor

Table 7: NMM Sectional Part List (Without Coupling)

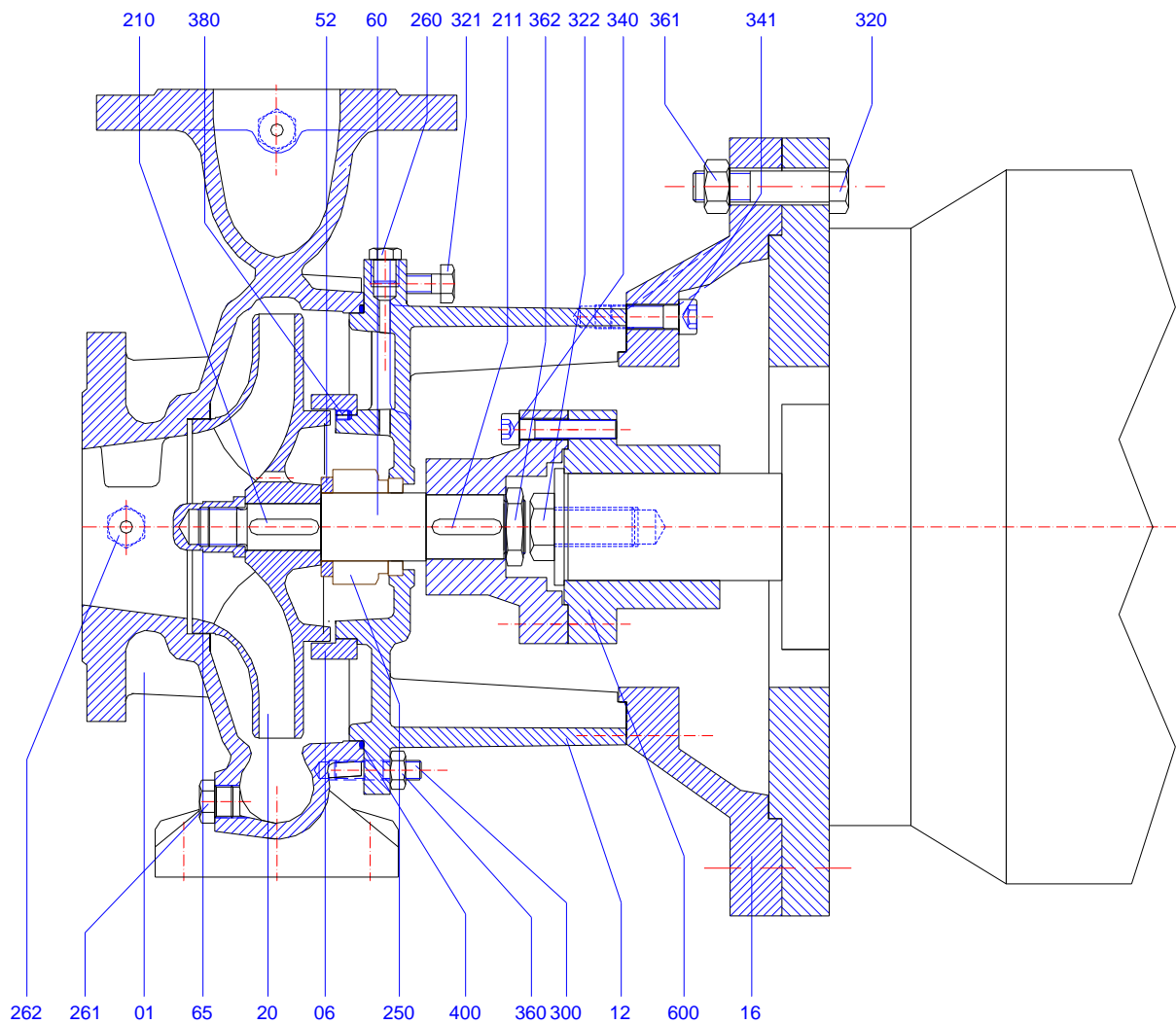
NMM SECTIONAL DRAWING AND PARTS LIST (WITH COUPLING)

Figure 9: NMM Sectional Drawing (With Coupling)

PART NO	PART NAME	PART NO	PART NAME
01	Pump Casing	262	Plug, Pump Casing
06	Wearing Ring	300	Stud, Pump Casing
12	Adapter	320	Hexagonal Bolt
16	Motor Flange	321	Hexagonal Bolt
20	Impeller	322	Hexagonal Bolt
52	Mech. Seal Ring	340	Imbus Bolt
60	Pump Shaft	341	Imbus Bolt
65	Impeller Nut	360	Nut
210	Impeller Key	361	Nut
211	Coupling Key	362	Nut
250	Mechanical Seal	380	Setscrew
260	Plug	400	O-Ring
261	Drain Plug	600	Coupling

Table 8: NMM Sectional Part List (With Coupling)

Note: This coupling system is applied with a motor power 30 KW and over.

17. NMM DRAWING FOR DISMANTLING (WITHOUT COUPLING)

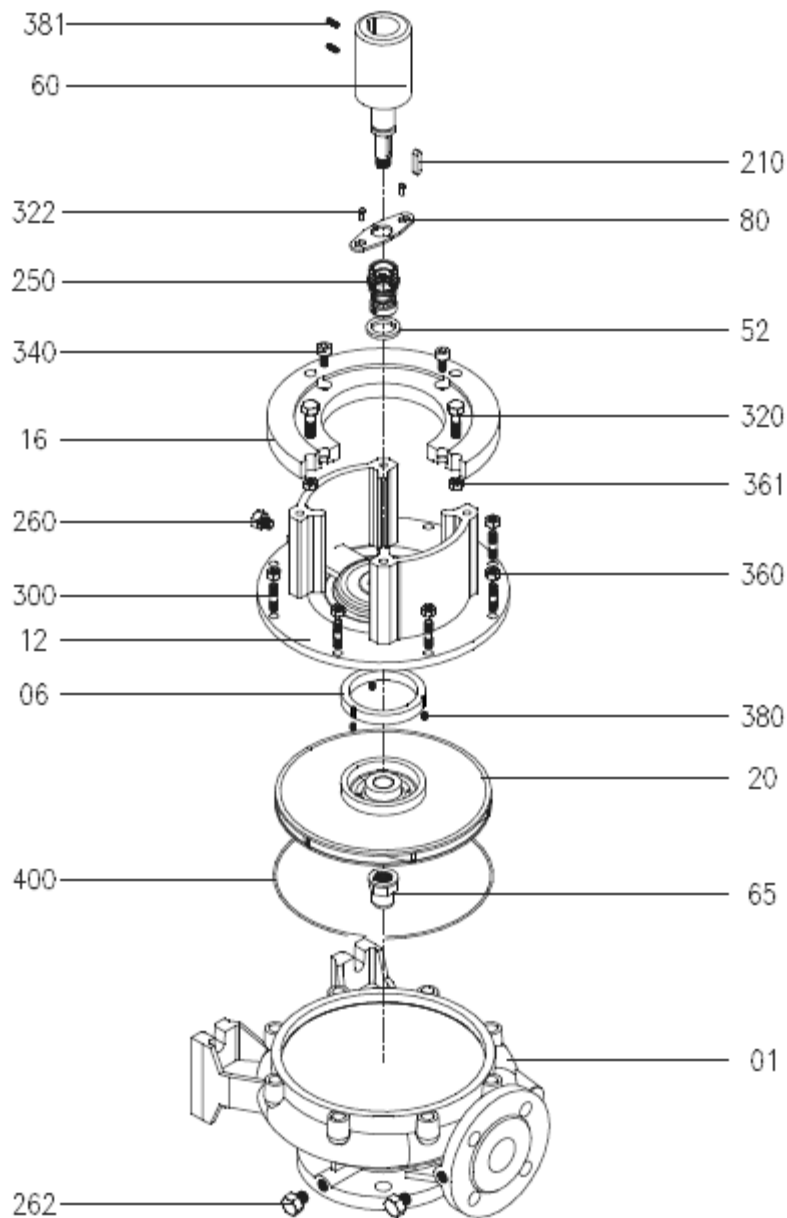

Figure 10: NMM Drawing For Dismantling (Without Coupling)

PART NO	PART NAME	PART NO	PART NAME
01	Volute Casing	260	Plug, Adapter
06	Wear Ring	262	Plug, Volute Casing
12	Adapter	300	Stud, Volute Casing
16	Adapter Flange	320	Hex Bolt
20	Impeller	322	Hex Bolt
52	Mechanical Seal Ring	340	Cap Screw
60	Pump Shaft	360	Nut
65	Impeller Nut	361	Nut
80	Shackle	380	Setscrew
210	Impeller Key	381	Setscrew
250	Mechanical Seal	400	O-Ring

Table 9: NMM Drawing For Dismantling Part List (Without Coupling)

NMM DRAWING FOR DISMANTLING (WITH COUPLING)

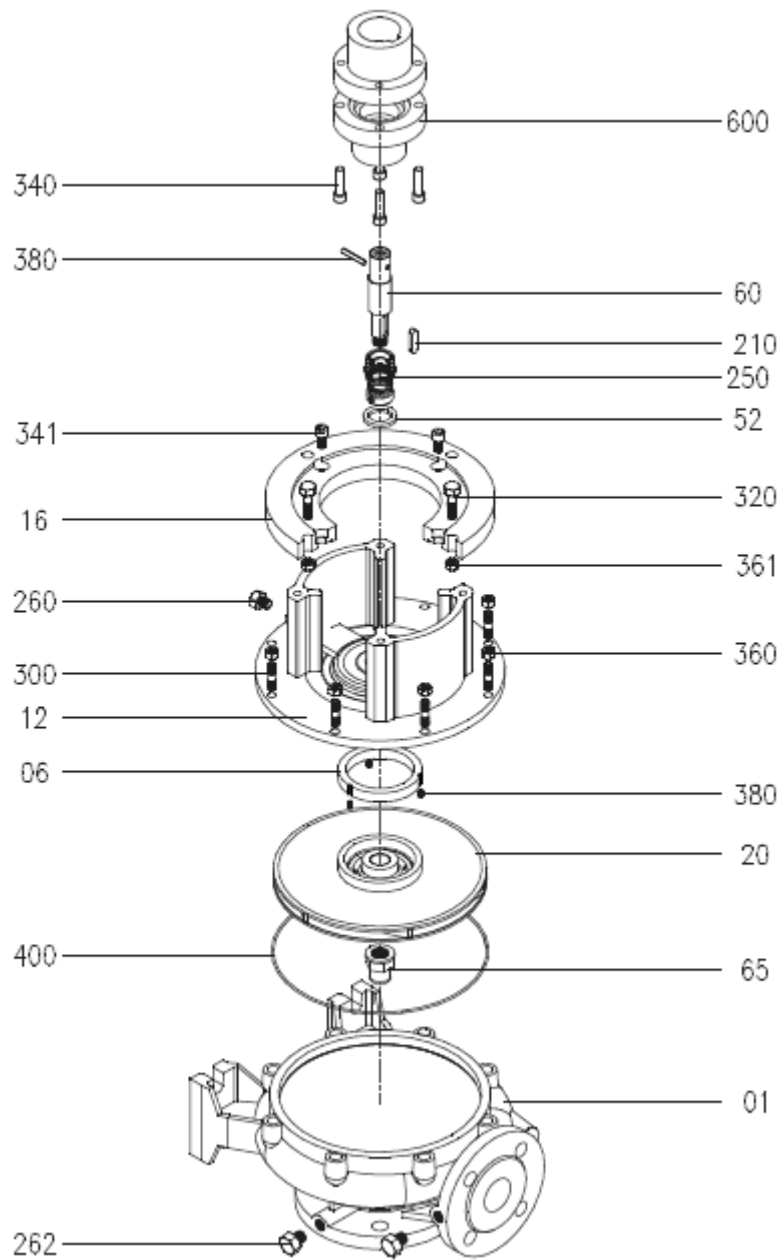

Figure 11: NMM Drawing For Dismantling (With Coupling)

PART NO	PART NAME	PART NO	PART NAME
01	Volute Casing	262	Plug, Volute Casing
06	Wear Ring	300	Stud, Volute Casing
12	Adapter	320	Hex Bolt
16	Adapter Flange	340	Cap Screw
20	Impeller	341	Cap Screw
52	Mechanical Seal Ring	360	Nut
60	Pump Shaft	361	Nut
65	Impeller Nut	380	Setscrew
210	Impeller Key	381	Setscrew
250	Mechanical Seal	400	O-Ring
260	Plug, Adapter	600	Rigid Coupling

Table 10: NMM Drawing For Dismantling Part List (With Coupling)

18. NMM SERIES MEI VALUE TABLE

Pump Type	Speed (rpm)	MEI
NMM 32-160	1450	0.4
NMM 32-200	1450	0.7
NMM 32-250	1450	0.4
NMM 40-160	1450	0.4
NMM 40-200	1450	0.7
NMM 40-250	1450	0.7
NMM 50-160	1450	0.4
NMM 50-200	1450	0.4
NMM 50-250	1450	0.5
NMM 50-315	1450	0.5
NMM 65-160	1450	0.7
NMM 65-200	1450	0.6
NMM 65-250	1450	0.4
NMM 65-315	1450	0.6
NMM 65-400	1450	0.5
NMM 80-160	1450	0.4
NMM 80-200	1450	0.5
NMM 80-250	1450	0.5
NMM 80-315	1450	0.5
NMM 80-400	1450	0.5
NMM 100-160	1450	0.5
NMM 100-200	1450	0.5
NMM 100-250	1450	0.4
NMM 100-315	1450	0.6
NMM 100-400	1450	0.5
NMM 125-200	1450	0.4
NMM 125-250	1450	0.5
NMM 125-315	1450	0.6
NMM 125-400	1450	0.6

Table 11: NMM MEI Table (1450 rpm)

Pump Type	Speed (rpm)	MEI
NMM 32-160	2900	0.4
NMM 32-200	2900	0.7
NMM 32-250	2900	0.4
NMM 40-160	2900	0.4
NMM 40-200	2900	0.7
NMM 40-250	2900	0.6
NMM 50-160	2900	0.4
NMM 50-200	2900	0.4
NMM 50-250	2900	0.4
NMM 65-160	2900	0.6
NMM 65-200	2900	0.4
NMM 65-250	2900	0.4
NMM 80-160	2900	0.4
NMM 80-200	2900	0.4
NMM 100-160	2900	0.5
NMM 100-200	2900	0.4

Table 12: NMM MEI Table (2900 rpm)

19. FIGURE LIST

		Page No
Figure 1	Pump Label	2
Figure 2	Transport of Pump Group	3
Figure 3	A Typical Concrete Foundation	4
Figure 4	Piping System	5
Figure 5	Electric Connection Diagram	5
Figure 6	NMM Pump Dimensions Figure	10
Figure 7	Sample Plumbing	16
Figure 8	NMM Sectional Drawing (Without Coupling)	17
Figure 9	NMM Sectional Drawing (With Coupling)	18
Figure 10	NMM Drawing For Dismantling (Without Coupling)	19
Figure 11	NMM Drawing For Dismantling (With Coupling)	20

20. TABLE LIST

		Page No
Table 1	Spare Part List	7
Table 2	Sound Pressure Level	7
Table 3	Possible Failures, Causes, Solutions	9
Table 4	NMM Pump Dimensions Table	10
Table 5	Tightening Torques Table	14
Table 6	Forces and Moments at The Pump Flanges	15
Table 7	NMM Sectional Part List (Without Coupling)	17
Table 8	NMM Sectional Part List (With Coupling)	18
Table 9	NMM Drawing For Dismantling Part List (Without Coupling)	19
Table 10	NMM Drawing For Dismantling Part List (With Coupling)	20
Table 11	NMM MEI Table (1450 rpm)	21
Table 12	NMM MEI Table (2900 rpm)	21



Mas Grup

Head Office / Center Service:

Aydınlı Mah. Birlik OSB. 1.No'lu Cadde No:17 Tuzla - İSTANBUL / TURKEY
Tel: +90 (216) 456 47 00 pbx Fax: +90 (216) 455 14 24

Ankara Regional Directorate:

Aşağı Öveçler Mah. 1329 Sok. No:6/9 Öveçler ANKARA / TURKEY
Tel: +90 (312) 472 81 60-67 Fax: +90 (312) 472 82 51

Factory:

1. Organize Sanayi Bölgesi Parsel 249/5 Beyköy - DÜZCE / TURKEY
Tel: +90 (380) 553 73 88 Fax: +90 (380) 553 71 29