

Double Suction Horizontal Centrifugal Fire Pump

YPSP SERIES



OPERATING MANUAL



Mas Grup





EC DECLARATION OF CONFORMITY

AT UYGUNLUK BEYANI

Manufacturer / İmalatçı : MAS DAF MAKİNA SANAYİ A.Ş.

Address / Adres : Aydınlı Mah. Birlik OSB. 1.No'lu Cadde No:17 Tuzla - İSTANBUL / TÜRKİYE

Name and address of the person authorised to compile the technical file : Vahdettin YIRTMAÇ
Aydınli Mah. Birlik OSB. 1.No'lu Cadde No:17
Teknik Dosyayı Derleyen Yetkili Kişi ve Adresi : Tuzla - İSTANBUL / TÜRKİYE

The undersigned Company certifies under its sole responsibility that the item of equipment specified below satisfies the requirements of the mainly Machinery Directive 2006/42/EC which is apply to it.

The item of equipment identified below has been subject to internal manufacturing checks with monitoring of the final assessment by **MAS DAF MAKİNA SANAYİ A.Ş.**

Aşağıda tanımlanmış olan ürünler için Makine Emniyeti yönetmeliği 2006 / 42 / AT' nin uygulanabilen gerekliliklerinin yerine getirildiğini ve sorumluluğun alınmış olduğunu beyan ederiz.

*Aşağıda tanımlanan ürünler içüretim kontrollerine bağılı olarak **MAS DAF MAKİNA SANAYİ A.Ş.** tarafından kontrol edilmiştir.*

Equipment / Ürün : Double Suction Horizontal Centrifugal Fire Pumps /
Çift Emişli Yatay Tip Santrifuj Yangın Pompaları
Seri / Model-Tip : YPSP Series - YPSP Serisi

For pumps supplied with drivers/ Elektrikli Pompa Üniteleri

Related Directives / Yönetmelikler

2006/42/EC Machinery Directive / 2006/42/AT Makine Emniyeti Yönetmeliği

2014/35/EU Low Voltage Directive / 2014/35/AB Alçak Gerilim Yönetmeliği

2014/30/EU Electromagnetic Compatibility Directive / 2014/30/AB Elektromanyetik Uyumluluk Yönetmeliği

EUP 2009/ 125 /EC Electric Used Products Directive/ Elektrik Kullanan Ekipmanlar Direktifi (EUP)

Regulations applied acc. to harmonize standards / Uygulanan Uyumlaştırılmış Standartlar

TS EN ISO 12100:2010, TS EN 809+A1, TS EN 60204-1:2011.

We hereby declare that this equipment is intended to be incorporated into, or assembled with other machinery to constitute relevant machinery to comply with essential health and safety requirements of Directive The machinery covered by this declaration must not be put into service until the relevant machinery into which it is to be incorporated has been declared in conformity with provisions of the directive.

Ekipman, uygun bir makina oluşturmak amacıyla diğer ekipmanlar ile birleştirilirken ya da monte edilirken gerekli sağlık ve güvenlik yönetmeliklerine uyulması gerekmektedir.

Bu bildiri kapsamında yönetmelikte belirtilen bütün hükümler yerine getirilmeden makinanın devreye alınmaması gerekmektedir.

Place and date of issue / Yer ve Tarih : İstanbul, 02.06.2014

Name and position of authorized person : Vahdettin YIRTMAÇ
Yetkili Kişinin Adı ve Görevi : General Manager / Genel Müdür

Signature of authorized person :

Yetkili Kişinin İmzası

TABLE OF CONTENTS

	Page No
Introduction	1
1. Important Safety Precautions	1
2. General	1
3. Safe Operating Conditions	2
4. Technical Information	2
5. Transport and Storage	3
6. Assembly/Installation	3
6.1. Installation	3
6.2. Type of Connection	3
6.3. Foundation	3
6.4. Coupling Alignment	4
6.5. Piping	5
6.6. Motor Connection	6
7. Commissioning ,Start Up And Operating	6
7.1. Preparations Before Start-Up	6
7.2. Checking the Direction of Rotation	6
7.3. Start-Up Procedure	7
7.4. Shut Down Procedure	7
8. Maintenance	7
8.1. Checking During Operation	7
8.2. Service	8
8.3. Spare Parts	8
9. Noise Level and Vibration	8
10. Disassembly, Repair and Reassembly	8
11. Possible Breakdown And Solution Methods	9
12. Pump Dimensions Table and Weights	10
13. Tightening Torques	10
14. Forces and Moments at the Pump Flanges	11
15. YPSP Sectional Drawing and Part List	12
16. YPSP Series Pump - Exploded View	13

INTRODUCTION



- This manual contains instructions for the installation, operation and maintenance of the horizontal split case pumps of **MAS DAF MAKİNA SANAYİ A.Ş.**
- Please read carefully this manual and apply all the instructions to operate pumps without problems. Pumps shall be used for their intended duties. In this manual, there are information on operating conditions, installation, starting-up, settings and main controls of pumps.
- These operating and maintenance instructions contain **MAS DAF MAKİNA SANAYİ A.Ş.**'s suggestions. The special operating and maintenance information of the plumbing that a pump is fitted to is not considered in these instructions. This information must be given by the plumbing constructors only.
- **Please refer to instructions of plumbing constructors.**
- Please pay attention to the warnings in this manual and ensure that it is read before the installation-start up process. **MAS DAF MAKİNA SANAYİ A.Ş.** is not responsible for the accidents resulting from negligence.
- If you cannot find an answer to your questions in this manual, it is suggested that you contact **MAS DAF MAKİNA SANAYİ A.Ş.** Please inform us about the rated value and especially the serial number of the pump when you get in contact for help
- The safety instructions in this manual cover the current national accident protection regulations. Beside all of these, an operation, work and safety measure imposed by the costumer has to be applied

The Signs Used in This Operation Manual



Read the instructions carefully in this operating manual and keep it for your future reference.



Warning sign against the electrical risks



Sign for the operator's safety.



1. IMPORTANT SAFETY PRECAUTIONS

In order to minimize the accidents during the mounting and putting into service of the pump, the following rules have to be applied:

1. Do not work without taking safety measures relevant to equipment. Cable, mask and safety band must be used when necessary.
2. Be sure there is adequate amount of oxygen and there is no toxic gaseous around
3. Before using welding or any electrical equipment make sure that there is no risk of explosion.
4. Check the cleanliness of the area to take care of your help. (Dust, smoke, etc.)
5. Do keep in mind that there is a risk of having accidents related to electricity
6. Do not lift the pump before you check the transport equipment.
7. Be sure you have a by-pass line
8. Use helmet, eye glasses and protective shoes for your safety
9. Place a protective barrier around the pump within the necessary safety area
10. Dust, liquids and gaseous that may cause overheating, short circuit, corrosion and fire must be kept away from the pump unit.
11. By checking the noise level of the pump unit, necessary measures to avoid noisy operation of the pump that can have harmful effects on the personnel and environment.
12. Be careful about the direction of transport and storage.
13. Cover appropriately the moving parts to avoid possible injury of the personnel. Mount the coupling guard and belting before starting-up the pump
14. All the electrical and electronic applications must be performed by authorized person conforming EN60204-1 and /or domestic instructions.
15. Protect the electrical equipment and motor against overloading
16. If flammable and explosive liquids are pumped, ground connection of electricity should be carried out properly
17. Do not expose the pump unit to sudden temperature variations
18. All personnel who work with the waste water system need to be vaccinated in case of contagious diseases.
19. If the pump contains hazardous liquids, one must use protective helmet against the risk of splatter. One also must accumulate the liquid in a proper container against any risk of leakage.

All Other Health and Safety Rules, Laws and Regulations Must Be Applied

2. GENERAL

2.1. Definition of Pump and Usage Areas

YPSP series pumps are split case horizontal pumps. They are used in

- Irrigation pump stations,
- Cooling water and circulation circuits
- Tap water pump stations
- Oil transmission pipeline stations,
- Various pumping stations for general purpose.

They must be used to transfer non-abrasive and non-flammable, clean liquids (up to 90°C) which do not contain large solid particles.





CAUTION

Please contact MAS DAF MAKİNA SANAYİ A.Ş. for liquids that have different chemical and physical specifications.

Technical specifications of YPSP type pumps

Suction Flange	: DN 80-DN 400
Discharge Flange	: DN 65-DN 350
Operating Pressure	: 16-20 Bar
Capacity	: 30-3000 m ³ /hour
Head	: 15-160 m
Speed	: 960-3600 rpm

Pump Label

 KALITE POMPA			MAS DAF MAKİNA SANAYİ A.Ş. T. Organize Sanayi Bölgesi Parsel 249/5 Beyköy/DÜZCE Tel :+90 216 456 47 00 Fax:+90 216 456 14 24 Uri: www.masgrup.com e-mail:info@masgrup.com	
TYPE:	YEAR:			
SERIAL NR:	Q :		m ³ /h	
POWER: kW	Hm:		mWc	
SPEED: RPM	ORDER NR :			
IMPELLER mm	SERVICE :			
DIAMETER:				
MADE IN TURKEY				

2.2. Performance Information

Actual performance of the pump can be obtained from the order page and/or from the test report. This information is given on the pump label. The performance curves given in the catalog are valid for water whose density and viscosity are $\rho=1 \text{ kg/dm}^3$ and $\nu=1 \text{ cst.}$ respectively. For those liquids whose densities and viscosities are different from those of water, please consult with MAS DAF MAKİNA SANAYİ A.Ş. since the performance curves vary with density and viscosity



Do not operate the pump with a motor that has a different power except for the given catalog and label values.

The pump is not to be operated at off-design point given in the order and supplied from the firm. It is necessary to ensure that the instructions are obeyed for the safe running of the pump.

2.3. Warranty Conditions

The entire products in our selling program are warranted by **MAS DAF MAKİNA SANAYİ A.Ş.**
Warranty period is 12 months after delivery.
Life of the product is 10 Years.
 The warranty conditions will only be valid when all the instructions about installation and start-up operations of the pump unit are taken into account.

2.4. Test

All Pumps are dispatched for sale when all the performance and pressure tests are completed. Proper assurance of material and fault-free operation of pumps whose performance tests are made is under the warranty of MAS DAF MAKİNA SANAYİ A.Ş.

2.5. Pressure Limit



Pressure at the discharge flange must not exceed 150% of the pump's head.

3. SAFE OPERATING CONDITIONS

This manual contains main safety instructions for the installation, operation and maintenance. It must be read by the personnel who are responsible for installation and operation. This manual should always be kept near the installation location. It is important to comply with safety precautions stated in page 1 along with the general safety instructions as well as preventive measures repeated in other sections of this manual.

3.1. Training of personnel

Installation, operation and maintenance personnel must have necessary knowledge in order to accomplish the given job. The responsibility, adequacies and controlling duties of such personnel must be determined by the costumer. It has to be certain that these personnel comprehend totally the content of the operating manual.

If the personnel do not have enough knowledge, required training must be given by the costumer. If training support is needed by the costumer, it will be provided by the manufacturer/seller



Untrained personnel and unwillingness to comply with safety instructions may be risky for both machine and environment. **MAS DAF MAKİNA SANAYİ A.Ş.** is not responsible for this kind of damages.

3.2. Hazardous conditions that may occur when one does not comply with the safety instructions

Incompliance with safety regulations may put the personnel, the environment and the machine in danger and thus may cause damages. Incompliance with safety regulations may give rise to situations listed below

Important operational functions of the factory may stop

Maintenance may get difficult.

One may get injured by electrical, mechanical or chemical hazards.

3.3. Safety measures for operator

Dangerous, hot or cold components in the pump area must be covered so that one cannot touch them.

Moving components of the pump (such as coupling) must be covered so that one cannot touch them. Those covers must not be dismantled while the pump is running. Dangers that results from electrical connections must be removed. To get more information about this subject, you can refer to VDE and domestic electrical instructions.

3.4. Safety measures for maintenance and installation

The costumer must assure that all maintenance, check and installment tasks are performed by qualified personnel. Repair work must only be performed while the machine is not running.

The pump and its auxiliary system must be cleaned thoroughly if it contains hazardous liquids. At the end of the repair work, all safety and protective equipment must be re-installed.

3.5. Spare parts replacement

Replacement of spare parts and all modifications must be done after contacting with the manufacturer. Spare parts and accessories certified by the manufacturer are important for the safe operation of the system.

Notice: MAS DAF MAKİNA SANAYİ A.Ş. is not responsible from the usage of improper spare parts.

4. TECHNICAL INFORMATION

4.1. Design

These are double suction, split case, horizontal pumps. Since the upper cover of the pump is dismantlable, all the internal components can easily be replaced without dismantling the pump case and the fittings. Stuffing box is cooled with water. Gland is easily dismantlable type. In this way, it is very easy to replace and fit up additional seals. Since the impeller is double suction type, axial force is balanced automatically.

4.1.1. Locations Of Flange – Flanges

Pumps have normally clockwise rotation when viewed from the driver side. In this case, suction opening is on the right and discharge opening is on the left. Suction and discharge flanges are concentric. Suction and discharge flanges are in accordance with DIN 2533-PN 16. It is possible to manufacture pumps with counter clockwise rotation.

4.1.2. Auxiliary fittings

Please refer to the technical drawing of the pump for necessary auxiliary fittings

4.1.3. Impeller

Specially and carefully designed impellers are closed type and have Francis type blades. They are balanced both statically and dynamically

4.1.4. Shaft

The shaft is longer for standard YPSP type pumps which have soft packing applications.

4.1.5. Bearing and Lubrication

Rolling bearings are used in YPSP type pumps. They support radial load caused by the impeller. A NU series cylindrical bearing at the motor side of the pump and a 63-C3 series ball bearing on the other side of the shaft are used. They are all long life rolling bearings. Rolling bearings are lubricated with grease.

Since the impeller is double suction type, the axial force balances automatically. To prevent the leakage flow into bearing housing, there are deflectors in front of the bearing covers.

4.1.6. Seals

In YPSP type pumps gland squeezed, teflon knit soft packing are used. There is a lantern ring in the stuffing box.

- Non-cooled packing is standard. (It is acceptable up to 90° C)

(See The Fig. 11 : Design with soft packing)

4.2. Construction Of Pump Group

4.2.1. Drive

A hermetic, 3 phase, fan cooled, squirrel caged, in accordance with DIN 42673-IM 1001B3 type electrical motor which complies with DIN IEC and VDE is used to drive the pump in proper speed and power.

Specifications of electrical motor

Isolation class	: F
Protection class	: IP 54-IP 55
Frequency	: 50 Hz.
Running type	: S1
Start up type	: 3x380 V(Y) up to 4 kW More than 4 kW, 3x380(Δ) + (Y/ Δ)

There is another possible application to drive the pump with a diesel engine.

4.2.2. Coupling and coupling cover

A flexible shaft coupling with or without secondary component in accordance with DIN 740 is used. A coupling cover is given in accordance with EN 294 in case of the pump group includes the coupling and chassis.



Pump can only be run with a coupling guard in accordance with EN 294 according to safety instructions. If there is no coupling cover, it is provided by the operator.

4.2.3. Base plate

It is manufactured from U profile steel in accordance with DIN 24259

5. TRANSPORT AND STORAGE

Suction, discharge and all auxiliary fittings must be closed during transport and storage. Dead-end covers must be removed while the pump unit is being installed.

5.1. Transport

Pump and pump group must be carried safely to the installation location by lifting equipments.



Current general lifting safety instructions must be applied. Please use a suspension system shown in figure while you are carrying and lifting the pump unit. The suspension rings may be broken because of the excessive load and may result in a damage of the pump. Prefer fabric cable for suspension

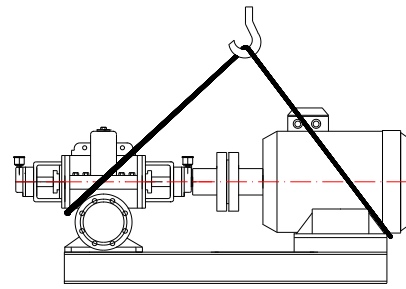

Fig.1: Transport of pump group



Incorrect lifting may damage the pump unit and cause injuries

Damages caused in transport.

Check the pump when it is delivered to you. Please let us know of there is any damage.

5.2. Storage



Please keep the unit clean and dry area during storage.

If the pump is out of use for a long time, please consider the instructions below:

- 1.If there is water inside the pump, drain it.
- 2.Clean the pump casing and impeller by jetting clean water for a short time.
- 3.Empty water inside the pump casing, suction line and discharge line.
- 4.Add small amount of antifreeze inside the pump casing if it is not possible to empty it completely. Rotate the pump shaft by hand to mix the antifreeze.
- 5.Close the suction and discharge exits with gasket
- 6.Spray an anti-corrosive into the pump casing.
- 7.Rotate the pump shaft by hand once in every month, in order to protect it from freezing and to lubricate the bearings

6. ASSEMBLY / INSTALLATION

6.1. Installation

In our standard production, the pump and the motor have been installed in a common base plate.

6.1.1. Location of Installation

Pump shall be installed in a location where the control and the maintenance of the pump are easily made. The pump room shall be suitable for operation of lifting systems such as freight elevator, forklift, etc.

The pump group should be installed in the lowest possible location of the pumping system in order to achieve the highest suction pressure.

6.1.2. Location of Installation- Local Ambient Temperature

When the local ambient room temperature exceeds +40 °C in a pumping system, suitable ventilation should be provided in order to remove the heat dissipated to the environment and supply fresh air.

6.2. Type of Connection

Type of connection depends on the design type and the size of the pump and the motor, as well as the local installation conditions. Foot-mounted horizontal pump-motor units have been installed in a common base plate.

6.3. Foundation

6.3.1. General

Base plate of the pump must be grouted. The foundation shall be of concrete or steel framework.

NOTE: The foundation shall distribute the weight of the pumping group evenly.

6.3.2. Main Properties of the Steel Framework Bases

Foundations with steel framework shall be designed in such a way that the base plate is bolted or welded contacting to all area.



If base plate is supported from only four points, pump group will stay in the middle, causing misalignment of the coupling and increasing the noise level.

6.3.3. Foundation Properties

The foundation shall be horizontal, flat and clean and shall support all the weight.

NOTE: Reinforced concrete bases are constructed from standard concrete with at least B 25 resistance class.

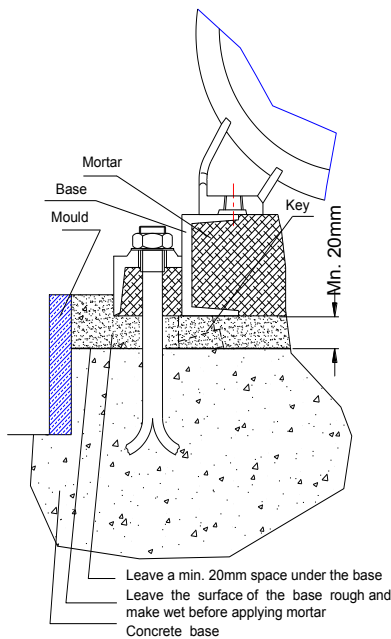

Figure 2. A typical concrete foundation

6.3.4. Fixing (Securing) of Pump Group

After the alignment of the pump group on the foundation has been made, the mutual securing bolt screws should be used alternately to fix the pump group. All of the area of the base plate should be filled with gout as much as possible.

NOTE: While securing pump group with the mortar bonding agents and molding, one has to make sure that the base plate contacts completely with the base with no cavities between the surfaces. Inside of the chassis (frame) should be completely filled with concrete

6.4. Coupling Alignment

6.4.1. General

For a proper operation of a pump group, a good alignment of the coupling is necessary. Vibration, noise, overheating of the bearings, overcharge problems can be attributed to the misalignment of coupling or using an improper coupling.

Flexible coupling does not correct the axial misalignments between the pump and the motor axes. However, it allows pinpointing the misalignments.

In order to avoid overheating, vibration, noise and wearing of the rolling bearings, alignment of the coupling has to be made properly and checked often.

Do not use a different coupling other than the original type installed on pumping group.

6.4.2 Method of Coupling Alignment

In order to make the alignment of the coupling, it is required to have at least two smooth edged metal pieces (e.g. a steel ruler or a gauge stick) and one precision calipers. (Figure 3.)

(For more precision alignments, special apparatus can be used).

Coupling misalignments in general are of two kinds:

1. Paralel axis misalignment (Figure4 - Figure 6)

In order to control paralel axis misalignment, a smooth edged gauge stick is pressed axially parallel over the upper half of the coupling. Then, the gauge stick is checked for the other half of the coupling. For alignment, the gauge stick shall be in contact with both of the halves at the same time. This procedure shall be repeated for four sides of the coupling. (i.e., top, bottom, left and right sides of the coupling). When all four sides give reasonably accepted results, alignment of the coupling has been ensured.



2. Angular Misalignment (Figure 5- Figure 7)

In order to control the angular misalignment, the distance between the two halves of the coupling is measured in both horizontal and vertical planes. Measurements taken at four points shall be in agreement for the alignment

Misalignments can be in horizontal or vertical planes. Misalignments in horizontal plane can be fixed by placing sheet iron at the bottom of the pump or motor base, while misalignments in vertical plane can be fixed by sliding the pump or the motor in horizontal plane.



Install the coupling guard only when the alignment of the coupling is checked.

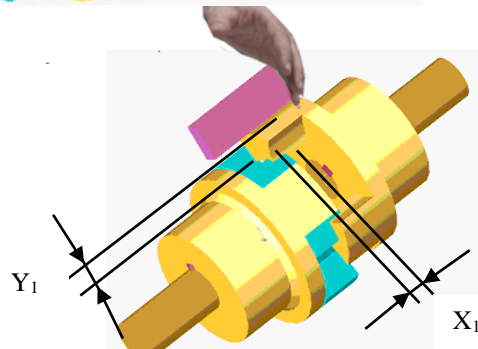
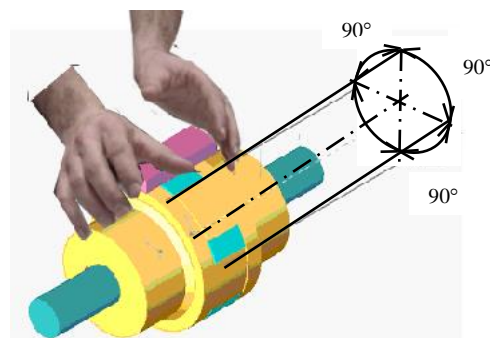

Figure 3. The control of the coupling alignment in horizontal and vertical planes.

Figures below illustrate the possible coupling misalignments and the methods to correct them.

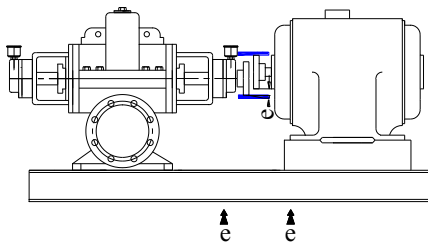

Figure 4: Parallel axis misalignment in vertical plane and its correction

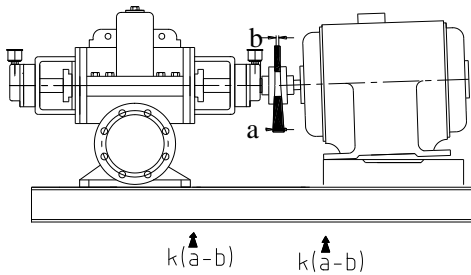

Figure 5: Angular misalignment in vertical plane and its correction

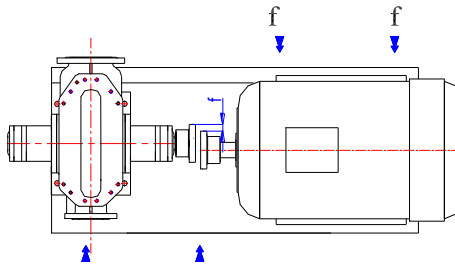

Figure 6: Parallel axis misalignment in horizontal plane and its correction

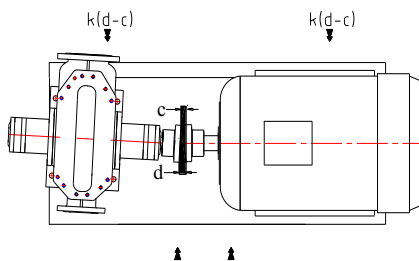

Figure 7. Angular misalignment in horizontal plane and its correction.

6.4.3. Pump and Motor Mounting (Coupling)

If the coupling of the pump group is to be mounted on site, the following procedure should be followed.

- 1.Coat the shaft tip of the pump and the motor sides with a sheet of molybdenum disulfide.
- 2.Push the coupling halves with a driving apparatus towards the pump and the motor shafts, until the shaft is fit to snag to the hub of the coupling. If a driving apparatus is not available, heating coupling halves (with coupling rubbers off) to an approximately 100 °C may help the pushing. It is important that axial force is prevented from occurring while mounting the coupling. Support pump shaft from the impeller side, and motor shaft from the fan side while mounting the coupling. If necessary, dismantle the fan cover.
- 3.Screw the two bolts in coupling hub.
- 4.Make sure that a suitable spacing is left between the coupling halves while mounting pump and the rotor.
- 5.Horizontal pump groups mounted on the base plate or directly mounted on the base, alignment of the coupling shall be as described in 6.4.2.
- 6.Put into place the coupling guard.

According to the accident prevention regulations, all preventions and protective devices should be in their intended place and in operational form.

6.5. Piping

6.5.1. General



- Do not use the pump as the hinged support for the piping system.
- Put enough supports under the piping system in order to carry the weight of the pipe and fittings.
- Avoid piping system loads on pump by installing flexible components (compensator) to suction and discharge of the pump.
- By mounting flexible supporting items, take into consideration the fact that these items may elongate under the pressure.
- Suction pipe shall be in a constantly increasing slope to the pump. Air in the suction pipe shall be arranged to move into the pump
- Discharge piping shall be in a constantly increasing slope to the reservoir or discharge point, without up and downs which can cause air pockets in the piping system. At locations where forming of air pockets is possible, special items like air valve and air cock are mounted to evacuate the trapped air.
- It is important that pipe diameter and fittings are at least as much as the pump opening diameter or preferable one or two size higher. One should never use fittings with smaller diameters than the pump exit diameter. In particular, preferred fittings like foot valve, strainer, filter, check valves and valves shall have large free passing area, and low friction loss coefficient.
- For piping systems with hot liquids, thermal expansions are to be taken into account and compensators shall be mounted in accordance with these expansions. Caution shall be exercised to avoid the loading of pump in this installation.

6.5.2. Specification of work in piping installation



In installation of pipes, follow the procedures below certainly.

- Install the pump on the concrete base as illustrated in Figure 2
- Take out the guards (placed by the manufacturer) from suction and discharge openings of the pump.
- Close the suction and discharge flanges with rubber gaskets. This precaution is important to avoid the undesired substances (weld crust, weld slag, sand, stone, wood piece etc.) get into the pump. Do not take off this gasket until the installation is completed.
- Start the installation of piping from the pump side. Do the necessary assembling and welding of the parts in a successive order.
- In these operations, do not neglect to put the necessary supports in their respected locations.
- Following above procedure, complete all piping system at suction side up to the suction tank (or foot valve if available), at discharge side up to do discharge collector and discharge pipe.
- When all installation and welding process is done and the heat dissipated by welding is removed, dismantle all the bolted connections from the suction tank to discharge pipe. Take out all demountable parts.
- Clean these parts and then paint body coat completely inside and outside.
- Mount the parts again in their intended places. However, this time start from the discharge line and move downward to the pump. In this instance, do not forget to check the flange gaskets. If needed, (for example deformation during welding) replace them.
- Concerning the connection of the pump flanges to piping, in case of misalignment of axis and flange holes, do not force the system to eliminate the misalignment. Forcing the system may cause difficult-to-correct problems.
- If there is an axial misalignment between the flanges of the pump and the pipe, due to the welding or any other reasons, cut the pipe from a suitable location in order to fix the problem. Connect the pipe (pump side) to the pump. After carrying out the necessary correction, connect the parts again by welding.
- Dismantle and clean the last welded part. Repaint again and mount on its place.

- After all these processes are accomplished, remove the rubber gasket from the suction and discharge openings. Open their holes and mount them again on their intended place.

6.5.3. Specification of work after installation of piping and piping system

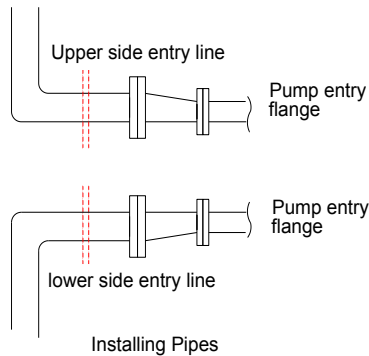

Figure 8. Piping system

An illustrative piping system is shown in Figure 10. Appropriate manometers shall be mounted on suction and discharge pipe lines.



Complete the auxiliary pipe connections in piping system if exist (cooling to bearing housing, and stuffing box (seal), relief pipe, oil pipe etc.)

6.6. Motor Connection

Motor shall be connected by an electrical technician according to the connection (switch) diagram. Local electricity policies and current VDE regulations have to be applied.



- Electrical connections have to be made by authorized electricians.
- In dismantling the pump, make sure the electricity is cut off before taking the motor cover out.
- Use the appropriate electrical connection to the motor

In environments where there is a risk of explosion, prescribed protective law and regulations shall be applied by competent authorities.

6.6.1. Motor Connection Diagram

- Motors requiring high moments at start up shall not be connected star-delta
- Frequency controlled motors, require high moment at start up and have to be cooled properly at low speeds. Provide the necessary cooling for the motors.

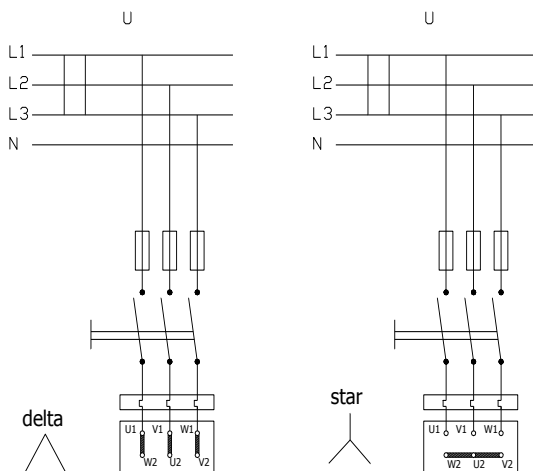

Figure 9. Electric Connection Diagram

El.line	Motor	
U (Volt)	230/400V	400V
3 x 230V	Delta	-
3 x 400V	Star	Delta

6.6.2. Motor Protection

- Three phased-motor shall be connected to power supply.
- Wait the motor to cool down when thermic protected motor breaks in circuit due to the overheating. Make sure the motor does not start automatically until it cools completely
- In order to protect the motor from overcharging and short circuit use a thermic or thermic-magnetic relay. Adjust this relay to the nominal current of the motor.

Electrical equipments, terminals and the components of the control systems may carry electric current even though they are not operating. They may cause deadly and serious injuries or irreparable material damages.

7. COMMISSIONING, START UP AND OPERATING

7.1. Preparations Before Start-Up

Oil Check: Ball bearings are used in YPSP type fire pumps. Long-life, NU series cylindrical bearings and one row, 63...-C3 series ball bearings are used respectively on the motor and the shaft sides, balance the axial force acting on the impeller. Bearings are lubricated with grease.

- Check pump seals
- Make sure that the pump and the suction pipe is completely filled with water before the starting. If the pump operates on a positive suction head, no problem will be encountered. Suction valve is opened and air drains are un-tightened.
- Pumps with foot valve are filled with water by opening the pump filling tap or, one takes advantage of the water accumulated in the discharge pipe and by using a small valve the check valve is bypassed and the pump is filled.
- In vacuum pump driven pumps, by operating the vacuum pump one achieves to fill the pump via increasing the water level in the suction pipe



Do not start your pump dry

7.2. Checking the Direction of Rotation



- The direction of rotation is indicated on the pump label with an arrow. Apart from special cases, it is clockwise direction when looking from the motor end. Observe if the pump is rotating in the expected sense by starting the motor for a very short instant. If it is turning in the opposite sense, interchange any of two motor leads.
- If the motor connection is delta, open the discharge valve slowly.
- If the motor connection is star-delta, set the time relay to maximum 30 seconds. Monitor the passage from star to delta by pressing the start button. As soon as you are assured that the connection is delta, open the discharge valve slowly. Continue opening the valve until you read the amperage on the electrical panel
- One should always check the labels which show the direction of rotation and the direction of fluid flow. If you dismount the coupling protection to monitor the direction of rotation, do not restart the engine before remounting the protection.

7.3. Start-Up Procedure

- Check if the suction valve is open and the discharge valve is closed. Start the motor
- Wait until the motor reaches sufficient speed. (In Star-delta connections, wait until the engine passes to delta connection.)
- Keeping an eye on the amperage shown on the panel, open the discharge valve slowly.
- In the primary operation, if the discharge pipe is empty, do not open the valve completely. By keeping an eye on the amperage, open the valve with care regarding that it should not exceed the value indicated on pump's label.
- After opening the valve completely, check the pressure from the pump exit manometer and make sure that this value is the pump operating pressure value and is indicated on pump's label.
- If the value one reads is less than the pump label value when the valve is completely open, it means that the height is miscalculated. Increase the value by narrowing the valve and bring it to pump's label value.
- If the value one reads is greater than the pump label value when the valve is completely open, it means that the height is calculated less than what it should be in reality. The device is pumping less than what is requested. Check the installation and the calculations.
- Minimum flow rate: If the pump is working with zero flow rate (closed valve) from time to time during its operation, the water inside the pump may endanger the pump by getting warmed up. In such cases, a minimum flow valve must be connected to the pump exit.

CAUTION

**Stop the motor if the pump gets too hot. Wait until it gets cold.
Then start the system up again carefully.**

7.4. Shut Down Procedure

CAUTION

During sudden start ups and stops, a pressure reducing valve must be placed at the exit section of high flow rate pumps whose discharge pipelines are long, in order to reduce water hammer effect. Water hammer may explode the pump.

In normal conditions (apart from sudden power shut down, etc), stop the pump as below:

- Close the discharge valve slowly
- Switch the power off, stop the motor. Notice that the rotor slows down.
- Do not start up the motor at least before 1 to 2 minutes.
- If the pump will be out of use for a long time, close the suction valve and auxiliary circuits. If the pump is outside and if there exists a danger of frost, remove all drain taps and empty all the water inside the pump. (5.2. Storage)



If the pump is outside and if there exists a danger of frost, remove all drain taps and empty all the water inside the pump.

8. MAINTENANCE

CAUTION

Maintenance operations must be done by authorized personnel with protective clothing only. The personnel must also beware of high temperatures and harmful and/or caustic liquids. Make sure that the personnel reads carefully the manual.

- The instructions in Safety Precautions must be executed during maintenance and repair
- Continuous monitoring and maintenance will increase the engine's and pump's lives.

8.1. Checking During Operation

- Pump must never be operated without water.
- Pump must not be operated for a long time with the discharge valve closed (zero capacity).
- Bearing temperature must never exceed 80°C if the ambient temperature is 30°C
- Precautions must be taken against flare up when the component temperatures are over 60°C. "Hot Surface" warnings must be placed over necessary areas.
- All the auxiliary systems must be in use while the pump is operating.
- Water must drop from the glands of stuffing boxes (20-30 drops per minute)
- Gland nuts must not be tightened too much. If the amount of water increases after a long operation time, the nuts may be tightened by 1/6 turns
- If the system consists of a substitute pump, keep it ready by operating it once a week. Check also the auxiliary systems of the substitute pump.
- Check the elastic components of the coupling. Replace them when necessary.

8.1.1. Component Check



To make possible the visual control, one must be able to reach the pump from any direction. Especially, to be able to dismount the internal units of the pump and the engine, sufficient free space must be created around them for maintenance and repair. Furthermore, one must make sure that the piping system can easily be dismounted.

8.1.1.1. Bearing and Lubrication

Ball bearings are used in YPSP type fire pumps. Long-life, NU series cylindrical bearings and one row, 63..-C3 series ball bearings are used respectively on the motor and the shaft sides, in order to balance axial forces acting on the impeller. Bearings are lubricated with grease oil.

8.1.2. Shaft Seal Maintenance

8.1.2.1. Soft Packing

- Before replacing the soft packing, the gland must be dismounted first. Used packing rings may be taken off by a sharp pointed tool. Take off the lantern ring if it exists, then clean the interiors of the sealing box, the gland and the lantern ring.
- Wrap a proper sized, good quality sealing over the shaft bush and make sure that the bush tip is completely covered.
- Place the first ring, its joint facing upwards and push it to its bed by using the gland
- If it exists push the watering ring to its bed.
- Place also the other rings to their beds alternating, i.e., their joints facing upwards and downwards.
- After placing the last ring, position the gland and tighten it completely. Thus, the squeezed sealing rings take the shape of the sealing box.
- Then un-tighten the nuts. Rotating the shaft tighten them slowly again. When you feel that the shaft is put on a brake, stop the tightening.
- Water must come from the seals drop by drop as soon as the pump is started. The number of drops must not be less than 10 and not more than 30 per minute. Find the proper setting by tightening and un-tightening the opposite gland nuts.



- Ensure that the water leaking from the sealing is collected and/or discharged in a manner which is appropriate in terms of safety and environmental criteria.
- Check the sealing temperature two hours after the gland adjustment is made. For a system which pumps water at ambient temperature, the sealing temperature must not exceed 80°C.

CAUTION

When tightening the gland nuts do not work with long sleeve shirts. Otherwise it is possible to get caught by the turning shaft and get injured.

8.1.3. Coupling

As mentioned in Section 6.4, coupling adjustment must be checked regularly.



Worn out elastic bands must be replaced.

8.1.4. Drive

Apply to the operating instructions of the motor manufacturer.

8.1.5. Auxiliary Components

Check regularly the fittings and the gaskets, replace the worn out pieces

8.2. Service

Our Customer Service Department offers after-sale service. Manager should employ authorized and trained personnel for mounting/dismounting procedures. Before these procedures, one must make sure that pump interior is clean and empty. This criterion is also valid for the pumps which are sent to our factory or to our service points.



Maintain the safety of the personnel and the environment in every field procedure.

8.3. Spare Parts

The spare parts of YPSP type pumps are guaranteed for 10 years by **MAS DAF MAKİNA SANAYİ A.Ş.**

In your spare parts requests, please indicate the below listed values that are indicated on your pump's label.

- Pump type and size:
- Motor power and speed:
- Pump serial number:
- Capacity and head:

If you wish to keep spare parts in store, depending on the number of same type of pumps, for two operation years, the quantities which are listed in the table below are recommended.

Component name	The number of equivalent pumps in the installation						
	1-2	3	4	5	6-7	8-9	10 +
Shaft (Wedge included) quantity	1	1	2	2	2	3	% 30
Impeller (quantity)	1	1	1	2	2	3	% 30
Casing wear (kit)	1	1	1	2	2	3	% 30
Ball bearing (kit)	1	1	2	2	3	4	% 50
O-Ring for casting (kit+1)	1	1	1	2	2	3	% 40
O-Ring for shaft (if exist) (kit)	1	1	2	2	3	4	% 50
Soft packing (kit)	2	2	2	3	3	4	% 50
Sealing bush(if exist)	1	1	1	2	2	3	% 30
Coupling rubber sleeves (kit)	1	2	2	3	3	4	% 50

9. NOISE LEVEL AND VIBRATION

The reasons which increase the noise level are indicated below:

- Touch of coupling halves due to worn rubber sleeves (incorrectly aligned)
- Noise level increases due to the fact that the pump is not founded properly (Vibration)
- If the installation does not have compensator noise and vibration increases.
- Wearing in ball bearing also increases noise level.



Check if there is any noise increasing elements in your installation.

9.1. Expected Noise Values

Mpower of Motor PN (KW)	Sound Pressure Level (dB) *	
	Pump with Motor	
	1450 rpm/min.	2900 rpm/min.
< 0.55	63	64
0.75	63	67
1.1	65	67
1.5	66	70
2.2	68	71
3	70	74
4	71	75
5.5	72	83
7.5	73	83
11	74	84
15	75	85
18.5	76	85
22	77	85
30	80	93
37	80	93
45	80	93
55	82	95
75	83	95
90	85	95
110	86	95
132	86	95
160	86	96

(*) Without protective sound hood, measured at a distance of 1 m directly above the driven pump, in a free space above a sound reflecting surface.

The above values are maximum values. The surface noise pressure level at dB(A) unit is shown as (L_{pA}). This complies with TS EN ISO 20361.

10. DISASSEMBLY, REPAIR AND REASSEMBLY

CAUTION

- Before starting work on the pumpset, make sure it is disconnected from the mains and can not be switched on accidentally.
- Follow the safety precaution measures outlined in "safety instructions".

10.1. Disassembly

- Close all valves in the suction and discharge lines, and drain the pump by opening the drain plug (260) and the air plug (261).
- Remove coupling guard and other safety guards
- Remove all casing main joint nuts (300) dowel pins and bearing housing (30) connecting bolts.
- Separate the casing halves, lifting off the upper half casing (02). This reveals the pump internals (impeller, wear rings) for inspection
- Unscrew the bolts which are connecting the bearing housings (30) to the bottom half casing (1).
- Lift the rotor out of the bottom half casing.
- Pull off the pump end coupling half from the shaft (60) using a pull-off device and remove the coupling key (211).
- Remove bearing covers (034) and bearing end covers
- Unscrew the shaft nuts (74) Pull the bearing housings (30) and bearings off the shaft (60).
- Pull out stuffing boxes (50) from the shaft.
- Remove impeller (25) and sleeves (70-73) by using a suitable device.
- Clean all the parts, replace damaged or worn-out ones.

10.2. Reassembly

- Reassembly proceeds in reverse sequence to dismantling as described in section 9.1. You may find the attached drawing useful. The following points should be noted more particularly:
- Never use old o-rings and make sure the new o-rings are the same size as the old ones.
- Before mounting the shaft protecting sleeves (70) inspect the condition of their rubbing faces. Use new sleeves if the old ones are badly worn, scored or rough.
- Place ball bearings on their places on the shaft by slightly heating or by using press.
- The joint faces of the casing halves are sealed with liquid sealing compound. The joint faces should be thoroughly cleaned before reassembly and coated over again with sealing compound. Never use a paper gasket between the two faces.

11. POSSIBLE FAILURES, CAUSES, SOLUTIONS

Possible failures and solution strategies are listed in the table below. Please apply to the Customers' Service Department of our company when a generic solution is not found to your problem.



While the failures are repaired the pump must always be dry and un-pressurized.

POSSIBLE FAILURE	CAUSES	SOLUTIONS
The pump delivers insufficient capacity	<ul style="list-style-type: none"> • Discharge head too high • Very high counter pressure • Pump and/or pipe cannot discharge air, cannot suck • Occurrence of air pockets inside the pipe • NPSH is too low 	<ul style="list-style-type: none"> • Readjust the operating point • See if there is any undesired material inside the pipe • Vent completely the pump and the pipe • Change the piping configuration • Increase the liquid level
Motor overload	<ul style="list-style-type: none"> • System pressure is lower than the requested pressure level • Speed too high • Liquid pumped of different specific gravity and viscosity than that for which pump is rated • Engine works at two phases 	<ul style="list-style-type: none"> • Adjust the operating pressure to the label value • Decrease the speed • Increase the engine power • Replace the fuse and control the electrical connections
Pump head is too high	<ul style="list-style-type: none"> • System pressure is higher than the requested pressure level 	<ul style="list-style-type: none"> • Set the operating pressure to the label value
Bearing temperatures are high	<ul style="list-style-type: none"> • Worn out coupling • Too much, too little or improper lubrication • Increase in axial forcing 	<ul style="list-style-type: none"> • Replace the coupling • Change the oil, decrease or increase its quantity • Clean the balance holes on the impeller disc
Excessive leakage from the stuffing box	<ul style="list-style-type: none"> • Worn out gland • Loose gland 	<ul style="list-style-type: none"> • Use brand new gland • Change the stuffing bush • Tighten the gland nuts
Noisy operation	<ul style="list-style-type: none"> • Worn out motor or pump ball bearings • Cavitation • Worn out or misaligned coupling • Operation in the far left or right of the performance curve 	<ul style="list-style-type: none"> • Replace • Close the delivery partially in order to reduce the capacity. • Replace the coupling or align it • Operate the pump at its label setting
Excessive increase in pump temperature	<ul style="list-style-type: none"> • Pump and/or pipe can neither discharge, nor aspirate air • Too low capacity 	<ul style="list-style-type: none"> • Bleed completely the pump and the pipe • Open more the valve
Vibration	<ul style="list-style-type: none"> • Pump and/or pipe can neither discharge, nor aspirate air • NPSH is too low • Internal components of the pump are worn out • System pressure is lower than the requested pressure level • Coupling is misaligned • Too much, too little or improper lubrication • Rotor unbalanced • Improper bearings 	<ul style="list-style-type: none"> • Bleed completely the pump and the pipe • Increase the liquid level • Replace the worn out components • Adjust the operating pressure to the label value • Align the coupling • In case of continuous overload, decrease the impeller diameter • Change the oil, decrease or increase its quantity • Balance the impeller again • Use new bearings

12. PUMP DIMENSIONS TABLE AND WEIGHTS

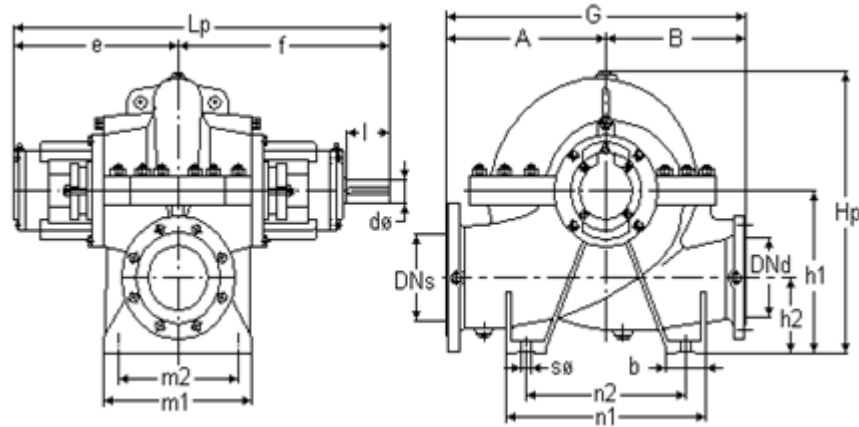

No	Pump Type	FLANGES		Lp	e	f	h1	h2	b	m1	m2	n1	n2	s(Ø)	A	B	I	d(Ø)	Hp	G	GROUP	Weight (Kg)
		DN Suction	DN Discharge																			
1	YPSP 65-250	100	65	585	260	325	250	115	90	240	200	350	275	18	275	225	60	28	432	500	A	105
2	YPSP 80-250						280	140							300				482	575		145
3	YPSP 80-360	125	80	674	294	380		135		234	190								555			165
4	YPSP 100-250			712	312	400	315	155	80	270	225	400	340	19	325	275	80	35	525	600	B	180
5	YPSP 100-315	150	100	820	350	470	355	145	110	290	230	435	350	22	365				587	690		330
6	YPSP 150-250	200	150	870	375	495				340	270	500	400		400	325		45	640	725	C	
7	YPSP 125-400	150	125									500	500		450	400			695	850		485
8	YPSP 150-315						375	175				500	400		400	350			645	750		410
9	YPSP 150-400						400	200				600	500		475	400			730	875		515
10	YPSP 150-500	200	150	942	412	530	450	250		370	300	650	550		550	500			870	1050		590
11	YPSP 200-315											500	400		450	375			735	825		565
12	YPSP 200-400			972	427	545	430	205		430	360	600	500		525	425	110	55	788	950	D	645
13	YPSP 200-500	250	200	1042	447	595	475	220		460	390				550	500			876	1050		760
14	YPSP 250-315			1062	457	605				480	410				525	425			841	950		750
15	YPSP 250-400			1042	447	595	500	225		460	390				550	450			873	1000		700
16	YPSP 250-500	300	250	1062	457	605	525	240	100	480	410	650	550	23	600			65	952		E	850
17	YPSP 350-400						610	295				750	600		600	500			1010	1100		
18	YPSP 350-500	400	350	1290	570	720	630	315	150	600	500	800	650	28	650	550	140	75	1055	1200	F	1750

13. TIGHTENING TORQUES

Thread Diameter	Tightening Torque Max (Nm)	
	Property Classes	
	8.8	10.9
M4	3.0	4.4
M5	5.9	8.7
M6	10	15
M8	25	36
M10	49	72
M12	85	125
M14	135	200
M16	210	310
M18	300	430
M20	425	610
M22	580	820
M24	730	1050
M27	1100	1550
M30	1450	2100
M33	1970	2770
M36	2530	3560

14. FORCES AND MOMENTS AT THE PUMP FLANGES

All of the applied loads if not reached the maximum allowable value, to provide that the following additional conditions, one of these loads may exceed the normal limit:

- Any component of a force or a moment, must be limited 1.4 times of the maximum allowable value,
- The actual forces and moments acting on each flange, should provide the following formula:

$$\left(\frac{\sum |F|_{\text{actual}}}{\sum |F|_{\text{maximum allowable}}} \right)^2 + \left(\frac{\sum |M|_{\text{actual}}}{\sum |M|_{\text{maximum allowable}}} \right)^2 \leq 2$$

In here, $\sum |F|$ and $\sum |M|$ are arithmetic sum of the loads for each flange at the pump level, without regard of the algebraic signs of the actual and maximum allowable values.

Pump Type	DN Flange		Forces						Moments					
			Suction Flange			Discharge Flange			Suction Flange			Discharge Flange		
	Suction	Discharge	N			N			Nm			Nm		
		F _y	F _z	F _x	F _y	F _z	F _x	M _y	M _z	M _x	M _y	M _z	M _x	
YPSP 65-250	100	65	1276	1029	1143	800	648	705	476	552	667	419	457	571
YPSP 80-250	125	80	1505	1219	1352	952	781	857	571	724	800	438	495	610
YPSP 80-360														
YPSP 100-250	150	100	1905	1543	1714	1276	1029	1143	667	781	952	476	552	667
YPSP 100-315														
YPSP 125-400						125	1505	1219	1352	952	781	857	571	724
YPSP 150-250	200	150	2552	2057	2286	1905	1543	1714	876,2	1010	1238	667	781	952
YPSP 150-315														
YPSP 150-400														
YPSP 150-500														
YPSP 200-315	250	200	3181	2571	2838	2552	2057	2286	1200	1391	1695	876	1010	1238
YPSP 200-400														
YPSP 200-500														
YPSP 250-315	300	250	3810	3067	3410	3181	2571	2838	1638	1886	2305	1200	1391	1695
YPSP 250-400														
YPSP 250-500														
YPSP 350-400	400	350	5067	4095	4552	4438	3581	3981	2629	3029	3695	2097	2422	2956

Forces at the pump flanges were calculated according to TS EN ISO 5199 standard. The calculations are valid for the materials of cast iron and bronze. Forces and moments at the flanges that made of stainless material will be approximately twice as moments in the table.

15.YPSP SECTIONAL DRAWING AND PARTS LIST

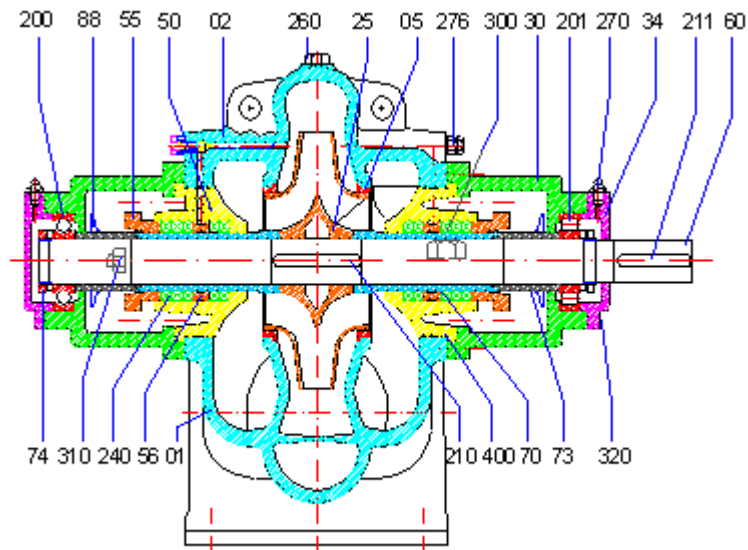
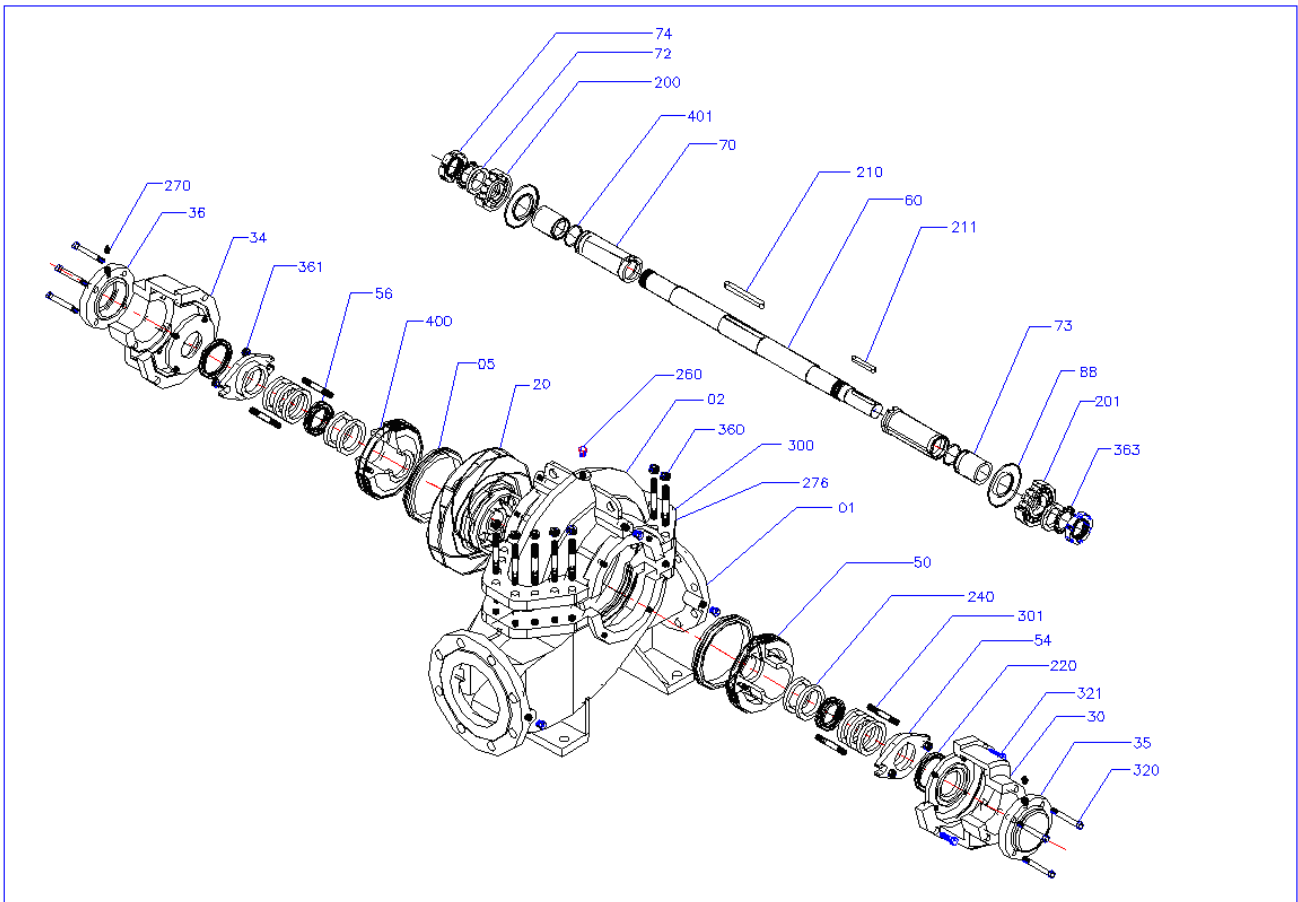

Figure 11: Soft Packing Design

PART LIST:

No	Name of the part	No	Name of the part
01	Casing-Lower Half	88	Deflector
02	Casing-Upper Half	200	Ball Bearing
05	Casing Ring	201	Roller Bearing
25	Double Suction Impeller	210	Impeller Key
30	Bearing Housing	211	Coupling Key
34	Bearing Cover (Coupling Side)	240	Soft Packing
50	Stuffing Box	260	Plug
55	Gland	270	Grease Thrower
56	Lantern Ring	276	Valve
60	Shaft	300	Casing Stud and Nut
70	Stuffing Box Bush	310	Gland Stud and Nut
73	Secondary Bush	320	Hex-Bolt
74	Shaft Adjusting Nut	400	O-Ring (For Casing)

16. YPSP SERIES PUMP - EXPLODED VIEW



PART NO	PART NAME	PART NO	PART NAME
01	Pump Casing	211	Coupling Key
20	Impeller	240	Gland Packing
30	Bearing Housing	260	Drain Plug
34	Bearing Housing Cover	300	Stud
39	Supporting Foot	301	Stud for Gland
50	Stuffing Box	302	Stud
54	Gland	320	Hexagonal Bolt
56	Lantern Ring	321	Hexagonal Bolt
60	Pump Shaft	360	Hexagonal Nut
65	Impeller Nut	361	Hexagonal Nut for Gland
200	Ball Bearing	362	Hexagonal Nut
210	Impeller Key	400	O-Ring



Mas Grup

Head Office / Center Service:

Aydınlı Mah. Birlik OSB. 1.No'lu Cadde No:17 Tuzla - İSTANBUL / TURKEY
Tel: +90 (216) 456 47 00 pbx Fax: +90 (216) 455 14 24

Ankara Regional Directorate:

Aşağı Öveçler Mah. 1329 Sok. No:6/9 Öveçler ANKARA / TURKEY
Tel: +90 (312) 472 81 60-67 Fax: +90 (312) 472 82 51

Factory:

1. Organize Sanayi Bölgesi Parsel 249/5 Beyköy - DÜZCE / TURKEY
Tel: +90 (380) 553 73 88 Fax: +90 (380) 553 71 29